

Room temperature controller
with universal input, 5gang
6109/18-500

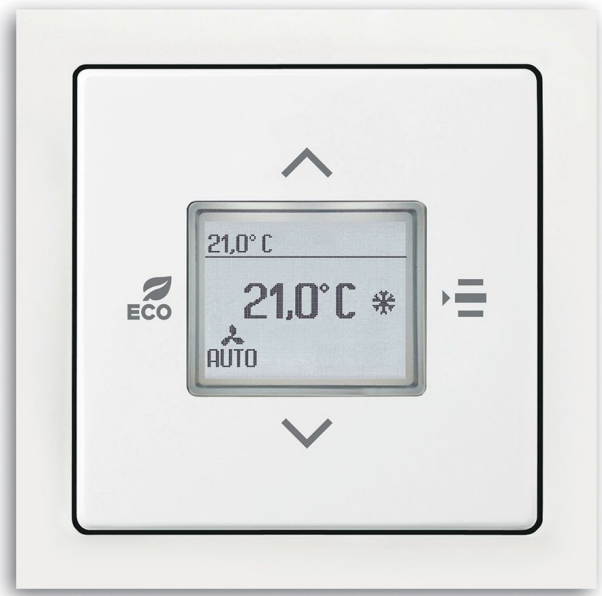

1	Notes on the instruction manual	10
2	Safety.....	11
2.1	Information and symbols used.....	11
2.2	Intended use.....	12
2.3	Improper use	12
2.4	Target group / Qualifications of personnel.....	13
2.4.1	Operation	13
2.4.2	Installation, commissioning and maintenance	13
2.5	Safety instructions	14
3	Information on protection of the environment	15
3.1	Environment	15
4	Setup and function	16
4.1	Functions.....	16
4.2	Sources of interference	16
4.3	Possible combinations.....	16
5	Technical data.....	17
6	Connection, installation / mounting	19
6.1	Installation site.....	20
6.2	Mounting.....	22
6.3	Electrical connection.....	24
7	Commissioning	25
7.1.1	Preparation	25
7.1.2	Assigning a physical address	25
7.1.3	Assigning the group address(es).....	25
7.1.4	Selecting the application program	25
7.1.5	Differentiating the application program.....	25
8	Operation	26
8.1	Control elements	26
8.2	Displays / messages.....	27
8.3	Operating modes and alarms	29
8.4	Setting operating modes/functions	30
8.4.1	Setting the setpoint temperature (required temperature)	30
8.4.2	Eco mode.....	31
8.4.3	Switching On and Off.....	32
8.4.4	Adjusting the fan speed levels.....	33
8.4.5	Changing the operating status (heating/cooling)	33
9	Maintenance	34
9.1	Cleaning	34
10	Description of application and parameters.....	35
10.1	Application program.....	35
10.2	Communication objects – Room air sensor.....	36
10.2.1	Send "0" in operation	36
10.2.2	Send "1" in operation	36
10.2.3	MC – Main counter reading.....	36
10.2.4	Request status	36

10.2.5	E1 – 1-byte value (-128 to 127)	37
10.2.6	E1 – 1-byte value (0 to 255)	37
10.2.7	E1 – 2-byte value (-32,768 to 32,767)	37
10.2.8	E1 – 2-byte value (0 to 65,535)	37
10.2.9	E1 – 2-byte floating point	37
10.2.10	E1 – 4-byte floating point	37
10.2.11	E1 – Request	38
10.2.12	E1 – Outside of range	38
10.2.13	E1 – Change threshold, tolerance band upper limit	38
10.2.14	E1 – Change threshold, tolerance band lower limit	38
10.2.15	E1 – Threshold value	38
10.2.16	E1 – Send if threshold value undershot	39
10.2.17	E1-E5 – Alarm sensor	39
10.2.18	E1-E5 – Scene storage display	39
10.2.19	E1-E5 – Actuating number	40
10.2.20	E1-E5 – Dimming	40
10.2.21	E1-E5 – Bottom end position	40
10.2.22	E1-E5 – Top end position	41
10.2.23	E1-E5 – Start event 0/1	41
10.2.24	E1-E5 – Blind UP/DOWN	41
10.2.25	E1-E5 – Priority (event 0)	42
10.2.26	E1-E5 – Priority (event 1)	42
10.2.27	E1-E5 – STOP/slat adjustment	42
10.2.28	E1-E5 – 2-byte floating point (event 0)	43
10.2.29	E1-E5 – 2-byte floating point (event 1)	43
10.2.30	E1-E5 – Switch (event 0)	43
10.2.31	E1-E5 – Switch (event 1)	44
10.2.32	E1-E5 – Switching sensor	44
10.2.33	E1-E5 – Enable save	44
10.2.34	E1-E5 – Disable	45
10.2.35	E1-E5 – Switch step up/down	46
10.2.36	E1-E5 – Scene	46
10.2.37	E1-E5 – Scene (event 0)	46
10.2.38	E1-E5 – Scene (event 1)	46
10.2.39	E1-E5 – Save scene	47
10.2.40	E1-E5 – Switching	47
10.2.41	E1-E5 – Switching – 1 actuation	47
10.2.42	E1-E5 – Switching – 2 actuations	48
10.2.43	E1-E5 – Switching – 3 actuations	48
10.2.44	E1-E5 – Switching – 4 actuations	48
10.2.45	E1-E5 – Switching – long actuation	48
10.2.46	E1-E5 – Switching – step 1	49
10.2.47	E1-E5 – Switching – step 2	49
10.2.48	E1-E5 – Switching – step 3	49
10.2.49	E1-E5 – Switching – step 4	49
10.2.50	E1-E5 – Switching – step 5	50
10.2.51	E1-E5 – 1-byte value – (-128 to 127) (event 0)	50
10.2.52	E1-E5 – 1-byte value – (-128 to 127) (event 1)	50
10.2.53	E1-E5 – 1-byte value – (0 to 255) (event 0)	51
10.2.54	E1-E5 – 1-byte value – (0 to 255) (event 1)	51
10.2.55	E1-E5 – 2-byte value – (-32,768 to 32,767) (event 0)	51
10.2.56	E1-E5 – 2-byte value – (-32,768 to 32,767) (event 1)	52

10.2.57	E1-E5 – 2-byte value – (0 to 65,535) (event 0).....	52
10.2.58	E1-E5 – 2-byte value – (0 to 65,535) (event 1).....	52
10.2.59	E1-E5 – 4-byte value – (-2,147,483,648 to 2,147,483,647) (event 0)	53
10.2.60	E1-E5 – 4-byte value – (-2,147,483,648 to 2,147,483,647) (event 1)	53
10.2.61	E1-E5 – 4-byte value – (0 to 4,294,967,295) (event 0)	54
10.2.62	E1-E5 – 4-byte value – (0 to 4,294,967,295) (event 1)	54
10.2.63	E1-E5 – MC – Request counter reading	54
10.2.64	E1-E5 – MC – Limit value exceeded	55
10.2.65	E1-E5 – MC – Counter reading 1-byte value	55
10.2.66	E1-E5 – MC – Counter reading 2-byte value	55
10.2.67	E1-E5 – MC – Counter reading 4-byte value	56
10.2.68	E1-E5 – IC – Stop	56
10.2.69	E1-E5 – IC – Limit value exceeded	56
10.2.70	E1-E5 – IC – Reverse direction	57
10.2.71	E1-E5 – IC – Reset	57
10.2.72	E1-E5 – IC – Counter reading 1-byte value	57
10.2.73	E1-E5 – IC – Counter reading 2-byte value	58
10.2.74	E1-E5 – IC – Counter reading 4-byte value	58
10.2.75	E1-E5 – IC – Request counter reading	58
10.2.76	E4 – 2-byte threshold value 1	59
10.2.77	E4 – 2-byte threshold value 2	59
10.2.78	E4 – Output value	59
10.2.79	E4 – Request output value	59
10.2.80	E4 – Bit threshold value 1	59
10.2.81	E4 – Bit threshold value 2	59
10.2.82	E4 – Byte threshold value 1	60
10.2.83	E4 – Byte threshold value 2	60
10.2.84	E4 – Measured value outside of range	60
10.2.85	E4 – Change threshold, tolerance band upper limit	60
10.2.86	E4 – Change threshold, tolerance band lower limit	60
10.2.87	E4 – Change threshold, tolerance band 2 upper limit	61
10.2.88	E4 – Change temperature, tolerance band 2 lower limit	61
10.2.89	E4 – Send if threshold value 1 undershot	61
10.2.90	E4 – Send if threshold value 1 exceeded	61
10.2.91	E4 – Temperature threshold value 1	62
10.2.92	E4 – Temperature threshold value 2	62
10.2.93	E4 – Heating temperature limit	62
10.2.94	P – Air pressure sensor error	62
10.2.95	P – Request relative air pressure	62
10.2.96	RFR – Basic set value (1 byte) [%]	63
10.2.97	RFR – Basic set value [%]	63
10.2.98	RFR – Blocking object	63
10.2.99	RFR – Blocking object threshold 1	63
10.2.100	RFR – Blocking object threshold 2	63
10.2.101	RFR – Blocking object threshold 3	64
10.2.102	RFR – Control value (0 to 100%)	64
10.2.103	RFR – Control value (0 to 255)	64
10.2.104	RFR – Control value step 1 (priority)	64
10.2.105	RFR – Control value step 1 (switch object)	64
10.2.106	RFR – Control value step 2 (priority)	65
10.2.107	RFR – Control value step 2 (switch object)	65
10.2.108	RFR – Control value step 3 (priority)	65

10.2.109	RFR – Control value step 3 (switch object)	65
10.2.110	RFR — Scene (1 to 64)	65
10.2.111	T – Frost alarm.....	66
10.2.112	T – Heat alarm	66
10.2.113	T – Sensor error.....	66
10.2.114	T – Temperature value [°C]	66
10.2.115	T – Request temperature value	66
10.2.116	T – External temperature value [°C]	67
10.2.117	rH – Humidity value [%]	67
10.2.118	rH – Request humidity value.....	67
10.2.119	rH – External humidity value [%].....	67
10.2.120	rH – Sensor error	67
10.3	Application "RTC"	68
10.3.1	General - Device function	68
10.3.2	General - Control function.....	68
10.3.3	General - Operating mode after reset.....	69
10.3.4	General - Additional functions.....	69
10.3.5	General - Send cyclic "In operation" (min).....	70
10.3.6	Heating control.....	70
10.3.7	Heating control - Control value type	70
10.3.8	Heating control - Heating type	71
10.3.9	Heating control - P-component (x 0.1°C)	71
10.3.10	Heating control - I-component (min.)	71
10.3.11	Heating control - Extended settings.....	72
10.3.12	Basic stage heating.....	72
10.3.13	Basic stage heating - Status object heating.....	72
10.3.14	Basic stage heating - Mode of the control value.....	72
10.3.15	Basic stage heating - Hysteresis (x 0.1°C).....	72
10.3.16	Basic stage heating - Control value difference for sending of heating control value.....	73
10.3.17	Basic stage heating - Cyclic sending of the control value (min)	73
10.3.18	Basic stage heating - PWM cycle heating (min)	73
10.3.19	Basic stage heating - Maximum control value (0 - 255)	74
10.3.20	Basic stage heating - Minimum control value for basic load (0 to 255)	74
10.3.21	Control of additional heating stage	74
10.3.22	Control of additional heating stage - Control value type.....	75
10.3.23	Control of additional heating stage - Additional heating type	75
10.3.24	Control of additional heating stage - P-component (x 0.1°C).....	76
10.3.25	Control of additional heating stage - P-component (min)	76
10.3.26	Control of additional heating stage - Temperature difference to basic stage (x 0.1°C)	76
10.3.27	Control of additional heating stage - Extended settings	76
10.3.28	Additional heating stage.....	76
10.3.29	Additional heating stage - Mode of the control value.....	77
10.3.30	Additional heating stage - Hysteresis (x 0.1°C).....	77
10.3.31	Additional heating stage - Control value difference for sending of heating control value.....	77
10.3.32	Additional heating stage - Cyclic sending of the control value (min)	77
10.3.33	Additional heating stage - Maximum control value (0 - 255)	78
10.3.34	Cooling control	78
10.3.35	Cooling control - Control value type.....	78
10.3.36	Cooling control - Cooling type.....	79
10.3.37	Cooling control - P-component (x 0.1°C).....	79
10.3.38	Cooling control - I-component (min.)	80
10.3.39	Cooling control - Extended settings.....	80

10.3.40	Basic stage cooling	80
10.3.41	Basic stage cooling - Status object cooling	80
10.3.42	Basic stage cooling - Mode of the control value	80
10.3.43	Basic stage cooling - Hysteresis (x 0.1°C)	81
10.3.44	Basic stage cooling - Cyclic sending of the control value (min).....	81
10.3.45	Basic stage cooling	81
10.3.46	Basic stage cooling - Maximum control value (0 - 255).....	82
10.3.47	Basic stage cooling - Minimum control value for basic load (0 to 255).....	82
10.3.48	Control of additional cooling stage.....	82
10.3.49	Control of additional cooling stage - Cooling type	83
10.3.50	Control of additional cooling stage - P-component (x 0.1°C)	83
10.3.51	Control of additional cooling stage - P-component (min).....	84
10.3.52	Control of additional cooling stage - Extended settings.....	84
10.3.53	Additional cooling stage	84
10.3.54	Additional cooling stage - Mode of the control value	84
10.3.55	Additional cooling stage - Hysteresis (x 0.1°C)	84
10.3.56	Additional cooling stage - Control value difference for sending of cooling control value.....	85
10.3.57	Additional cooling stage - Cyclic sending of the control value (min).....	85
10.3.58	Additional cooling stage - Maximum control value (0 - 255).....	85
10.3.59	Additional cooling stage - Minimum control value for basic load (0 - 255)	86
10.3.60	Settings of basic load.....	86
10.3.61	Settings of basic load - Minimum control value for basic load > 0.....	86
10.3.62	Combined heating and cooling modes	86
10.3.63	Combined heating and cooling modes - Switchover of heating/cooling	87
10.3.64	Combined heating and cooling modes - Operating mode after reset	87
10.3.65	Combined heating and cooling modes - Heating/cooling control value output.....	87
10.3.66	Combined heating and cooling modes - Additional heating/cooling stage control value output.....	88
10.3.67	Setpoint settings	88
10.3.68	Setpoint settings - Setpoint for heating comfort = setpoint for cooling comfort	88
10.3.69	Setpoint settings - Hysteresis for switchover heating/cooling (x 0.1°C)	89
10.3.70	Setpoint settings - Setpoint temperature for heating and cooling comfort (°C).....	89
10.3.71	Setpoint settings - Setpoint temperature for heating comfort (°C)	89
10.3.72	Setpoint settings - Reduction for standby heating (°C)	89
10.3.73	Setpoint settings - Reduction for ECO heating (°C)	90
10.3.74	Setpoint settings - Set-point temperature for frost protection (°C)	90
10.3.75	Setpoint settings - Setpoint temperature for cooling comfort (°C).....	90
10.3.76	Setpoint settings - Increase for standby cooling (°C)	90
10.3.77	Setpoint settings - Increase for ECO cooling (°C)	90
10.3.78	Setpoint settings - Set-point temperature for heat protection (°C)	91
10.3.79	Setpoint settings - Display indicates	91
10.3.80	Setpoint settings - Display indicates	91
10.3.81	Setpoint settings - Send current setpoint.....	91
10.3.82	Setpoint settings - Cyclic sending of the current set-point temperature (min).....	92
10.3.83	Setpoint adjustment	92
10.3.84	Setpoint adjustment — Maximum manual increase during heating mode (0 - 15°C)	92
10.3.85	Setpoint adjustment — Maximum manual reduction during heating mode (0 - 15°C)	92
10.3.86	Setpoint adjustment — Maximum manual increase during cooling mode (0 - 15°C).....	92
10.3.87	Setpoint adjustment — Maximum manual reduction during cooling mode (0 - 15°C)	93
10.3.88	Setpoint adjustment - Resetting of the manual adjustment for receipt of a basic setpoint.....	93
10.3.89	Setpoint adjustment - Resetting the manual adjustment for change of operating mode.....	93
10.3.90	Setpoint adjustment - Resetting the manual adjustment via object.....	93
10.3.91	Setpoint adjustment - Permanent storage of on-site operation	94

10.3.92	Temperature reading - Inputs of temperature reading.....	94
10.3.93	Temperature reading - Inputs of weighted temperature reading	94
10.3.94	Temperature reading - Weighting of internal measurement (0 to 100%)	94
10.3.95	Temperature reading - Weighting of external measurement (0 to 100%)	95
10.3.96	Temperature reading - Weighting of external measurement 2 (0 to 100%)	95
10.3.97	Temperature reading - Cyclic sending of the actual temperature (min)	95
10.3.98	Temperature reading - Difference of value for sending the actual temperature (x 0.1°C)	95
10.3.99	Temperature reading - Adjustment value for internal temperature measurement (x 0.1°C)	96
10.3.100	Temperature reading - Monitoring time for temperature reading (0 = no monitoring) (min)	96
10.3.101	Temperature reading — Operating mode for fault.....	96
10.3.102	Temperature reading - Control value for fault (0 - 255)	96
10.3.103	Alarm functions	97
10.3.104	Alarm functions - Condensate water alarm.....	97
10.3.105	Alarm functions — Dew point alarm	97
10.3.106	Alarm functions - Frost alarm temperature for HVAC and RHCC status (°C).....	97
10.3.107	Alarm functions - Heat alarm temperature for RHCC status (°C).....	98
10.3.108	Fan coil settings - Fan speed levels	98
10.3.109	Fan coil settings - Fan speed levels Number of fan speed levels	98
10.3.110	Fan coil settings - Fan speed levels - Format of the level output	98
10.3.111	Fan coil settings - Fan speed levels - Level output.....	99
10.3.112	Fan coil settings - Fan speed levels - Lowest manually adjustable level	99
10.3.113	Fan coil settings - Fan speed levels - Level status evaluation	99
10.3.114	Fan coil settings heating	99
10.3.115	Fan coil settings for heating - Speed level 1 to 5 up to control value (0 to 255) heating	100
10.3.116	Fan coil settings for heating - Fan speed level limit heating for eco mode.....	100
10.3.117	Fan coil settings for heating - Maximum speed level heating for eco mode.....	100
10.3.118	Fan coil settings for cooling	100
10.3.119	Fan coil settings for cooling - Speed level 1 to 5 up to control value (0 to 255) cooling.....	101
10.3.120	Fan coil settings for cooling - Fan speed level limit cooling for eco mode.....	101
10.3.121	Fan coil settings for cooling - Maximum fan speed level cooling for eco mode	101
10.3.122	Summer compensation	101
10.3.123	Summer compensation - Summer compensation.....	101
10.3.124	Summer compensation - (Lower) Starting temperature for summer compensation (°C).....	102
10.3.125	Summer compensation - Offset of the set-point temperature for the entry into summer compensation (x 0.1°C).....	103
10.3.126	Summer compensation - (Upper) exit temperature for summer compensation (°C).....	103
10.3.127	Summer compensation - Offset of the set-point temperature for the exit from summer compensation (x 0.1°C)	104
10.4	Additional RTC application "Control settings".....	104
10.4.1	General – Jump-back to the primary function.....	104
10.4.2	Temperature display – Temperature unit.....	104
10.4.3	General - Setting the temperature unit via object	105
10.4.4	General - Setpoint display.....	105
10.4.5	General - Display of actual temperature	105
10.4.6	General - Waiting period for display of actual temperature	105
10.4.7	General - Display of actual temperature in eco mode	105
10.4.8	Brightness setting – Day/Night mode	106
10.4.9	Brightness setting – Brightness of display backlighting.....	106
10.4.10	Extended settings - Colour scheme of display backlighting	106
10.5	Communication objects - RTC.....	107
10.5.1	Heating control value	107
10.5.2	Additional heating stage.....	107

10.5.3	Cooling control value	107
10.5.4	Additional cooling stage	108
10.5.5	Control On/Off	108
10.5.6	Actual temperature	108
10.5.7	External actual temperature	109
10.5.8	External actual temperature 2	109
10.5.9	Fault, actual temperature	109
10.5.10	Local actual temperature	109
10.5.11	Current setpoint	110
10.5.12	Operating mode	110
10.5.13	Superimposed operating mode	111
10.5.14	Window contact	111
10.5.15	Presence detector	112
10.5.16	Heating status	112
10.5.17	Cooling status	112
10.5.18	Basic load	112
10.5.19	Switchover heating/cooling	113
10.5.20	Fan coil manual	113
10.5.21	Fan coil step	114
10.5.22	Fan coil step status	114
10.5.23	Fan speed level 1	114
10.5.24	Fan speed level 2	114
10.5.25	Fan speed level 3	115
10.5.26	Fan speed level 4	115
10.5.27	Fan speed level 5	115
10.5.28	Basic setpoint	115
10.5.29	Resetting manual setpoints	115
10.5.30	Dew point alarm	116
10.5.31	Condensate water alarm	116
10.5.32	Outside temperature for summer compensation	116
10.5.33	Summer compensation active	117
10.5.34	Setpoint reached	117
10.5.35	Fahrenheit	117
10.5.36	Display backlighting	118
10.5.37	On/Off request	118
10.5.38	Setpoint display	118
10.5.39	Request setpoint	118
10.5.40	Confirm setpoint	118
10.5.41	Heating/cooling request	119
10.5.42	Request fan speed level manually	119
10.5.43	Request fan speed level	119
10.5.44	Confirm fan speed level	119
10.5.45	Controller status RHCC	119
10.5.46	Controller status HVAC	120
10.5.47	Commissioned	120
10.6	Additional RTC communication objects "Control settings"	120
10.6.1	Day/Night mode	120
10.7	Application for "Button top right"	121
10.7.1	Application "1-button switching"	121
10.7.2	Application "1-button dimming"	121
10.7.3	Application "2-button value transmitter"	122

10.7.4	Application "1-button value transmitter, 2 objects"	123
10.7.5	Application "1-button light scene extension unit with memory function"	125
10.7.6	Application "1-button step switch"	126
10.7.7	Application "1-button short-long operation"	127
10.8	Application "General functions"	128
10.8.1	Cyclic telegram	128
10.8.2	Priority	129
10.8.3	Logic	130
10.8.4	Gate	131
10.8.5	Staircase lighting	131
10.8.6	Delay	132
10.8.7	Min/Max value transducer	133
10.8.8	Threshold value / hysteresis	134
10.8.9	Light scene actuator	134
11	Information about planning and application	135
11.1	Room air quality	135
11.1.1	Good air	135
11.1.2	KNX room climate control	135
12	Index	136

1 Notes on the instruction manual

Please read through this manual carefully and observe the information it contains. This will assist you in preventing injuries and damage to property, and ensure both reliable operation and a long service life for the device.

Please keep this manual in a safe place.

If you pass the device on, also pass on this manual along with it.

ABB accepts no liability for any failure to observe the instructions in this manual.

If you require additional information or have questions about the device, please contact ABB or visit our Internet site at:

www.BUSCH-JAEGER.com

2 Safety

The device has been constructed according to the latest valid regulations governing technology and is operationally reliable. It has been tested and left the factory in a technically safe and reliable state.

However, residual hazards remain. Read and adhere to the safety instructions to prevent hazards of this kind.

ABB accepts no liability for any failure to observe the safety instructions.

2.1 Information and symbols used

The following Instructions point to particular hazards involved in the use of the device or provide practical instructions:



Danger

Risk of death / serious damage to health

- The respective warning symbol in connection with the signal word "Danger" indicates an imminently threatening danger which leads to death or serious (irreversible) injuries.



Warning

Serious damage to health

- The respective warning symbol in connection with the signal word "Warning" indicates a threatening danger which can lead to death or serious (irreversible) injuries.



Caution

Damage to health

- The respective warning symbol in connection with the signal word "Caution" indicates a danger which can lead to minor (reversible) injuries.



Attention

Damage to property

- This symbol in connection with the signal word "Attention" indicates a situation which could cause damage to the product itself or to objects in its surroundings.



NOTE

This symbol in connection with the word "Note" indicates useful tips and recommendations for the efficient handling of the product.



This symbol alerts to electric voltage.

2.2 Intended use

This device is a room air monitoring device for flush-mounted installation.

The device is intended for the following:

- controlling the room temperature,
- determining/measuring the following values:
 - temperature
- operation according to the listed technical data,
- installation in dry interior rooms and suitable windproof flush-mounted boxes,
- use with the connecting options available on the device.

The additional room temperature control function is suitable for the control of a ventilator convector with fan coil actuator or a conventional heating and cooling system.

The intended use also includes adherence to all specifications in this manual.



NOTE

- The integrated bus coupler enables connection to a KNX bus line.
- Extensive functions are available for the device. For the range of applications, see chapter 10 “Description of application and parameters“ on page 35.

2.3 Improper use

Each use not listed in Chapter 2.2 “Intended use“ on page 12 is deemed improper use and can lead to personal injury and damage to property.

ABB is not liable for damages caused by use deemed contrary to the intended use of the device. The associated risk is borne exclusively by the user/operator.

The device is not intended for the following:

- Unauthorized structural changes
- Repairs
- Outdoor use
- The use in bathroom areas
- The control of the device serves for monitoring and regulating the quality of the air. It must not be used for safety-related tasks.

2.4 Target group / Qualifications of personnel

2.4.1 Operation

No special qualifications are needed to operate the device.

2.4.2 Installation, commissioning and maintenance

Installation, commissioning and maintenance of the device must only be carried out by trained and properly qualified electrical installers.

The electrical installer must have read and understood the manual and follow the instructions provided.

The electrical installer must adhere to the valid national regulations in his/her country governing the installation, functional test, repair and maintenance of electrical products.

The electrical installer must be familiar with and correctly apply the "five safety rules" (DIN VDE 0105, EN 50110):

1. Disconnect
2. Secure against being re-connected
3. Ensure there is no voltage
4. Connect to earth and short-circuit
5. Cover or barricade adjacent live parts

2.5 Safety instructions



Danger - Electric voltage!

Electric voltage! Risk of death and fire due to electric voltage of 100 ... 240 V. Dangerous currents flow through the body when coming into direct or indirect contact with live components. This can result in electric shock, burns or even death.

- Work on the 100 ... 240 V supply system may only be performed by authorised and qualified electricians.
- Disconnect the mains power supply before installation / disassembly.
- Never use the device with damaged connecting cables.
- Do not open covers firmly bolted to the housing of the device.
- Use the device only in a technically faultless state.
- Do not make changes to or perform repairs on the device, on its components or its accessories.
- Keep the device away from water and wet surroundings.



Danger - Electric voltage!

Install the device only if you have the necessary electrical engineering knowledge and experience.

- Incorrect installation endangers your life and that of the user of the electrical system.
- Incorrect installation can cause serious damage to property, e.g. due to fire.

The minimum necessary expert knowledge and requirements for the installation are as follows:

- Apply the "five safety rules" (DIN VDE 0105, EN 50110):
 1. Disconnect
 2. Secure against being re-connected
 3. Ensure there is no voltage
 4. Connect to earth and short-circuit
 5. Cover or barricade adjacent live parts.
- Use suitable personal protective clothing.
- Use only suitable tools and measuring devices.
- Check the type of supply network (TN system, IT system, TT system) to secure the following power supply conditions (classic connection to ground, protective earthing, necessary additional measures, etc.).



Caution! - Risk of damaging the device due to external factors!

Moisture and contamination can damage the device.

- Protect the device against humidity, dirt and damage during transport, storage and operation.

3 Information on protection of the environment

3.1 Environment



Consider the protection of the environment!

Used electric and electronic devices must not be disposed of with domestic waste.

- The device contains valuable raw materials which can be recycled. Therefore, dispose of the device at the appropriate collecting depot.

All packaging materials and devices bear the markings and test seals for proper disposal. Always dispose of the packaging material and electric devices and their components via the authorized collecting depots and disposal companies.

The products meet the legal requirements, in particular the laws governing electronic and electrical devices and the REACH ordinance.

(EU Directive 2012/19/EU WEEE and 2011/65/EU RoHS)

(EU REACH ordinance and law for the implementation of the ordinance (EC) No.1907/2006).

4 Setup and function

4.1 Functions

The device is a functional measuring device and is installed flush-mounted in the wall. As well as monitoring the air quality, it also offers the option of controlling room air conditioning.

The device measures the following values:

- Temperature

4.2 Sources of interference

The measured results of the device can be influenced negatively by external sources. The following contains possible sources of interference:

- Draught and movement of air.
 - E.g. from windows, doors, convection, heating or persons.
- Heating up or cooling down.
 - E.g. solar irradiation or mounting on an outside wall.
- Heat sources
 - In the direct vicinity of installed electric loads, e.g. dimmers
- Shocks or impacts the device was or is being subjected to.
- Contamination from paint, wallpaper adhesive, dust, etc.
 - E.g. during renovation work
- Organic solutions or their vapours.
 - E.g. cleaning agents.
- Softening agents from stick-on labels and packaging.
 - E.g. air-cushion foil or polystyrene

4.3 Possible combinations

	 6109/28-500
 6109/03-500	X

Table 1: Possible combinations

5 Technical data

Designation	Value
Power supply:	24 V DC (via bus line)
KNX connection:	Bus connecting terminal, screwless
Bus subscribers:	1 (≤ 12 mA)
Temperature range:	-5°C to +45°C
Storage temperature:	-10°C to +60°C
Protection type:	IP 20
Protection class:	III
Display size:	3.8 cm (1.5")
Dimensions of flush-mounted insert:	44 x 44 x 32 mm The screws for the flush-mounted box are used for installation.
Parameter setting:	Parameters are set using the ETS Tool Software.
Inputs:	
a) 4 binary inputs + 1 analogue input <ul style="list-style-type: none"> – Activation of sensors with external power supply – The external temperature sensor at E4/5 does not require an external power supply. When connecting an analogue external sensor, the 0 to 10 V or the 1 to 10 V must be supplied from the sensor. – Binary input power supply: supplied by the device. 	1 to 10 V / 0 to 10 V
b) 2 binary inputs + 1 analogue input + external temperature sensor <ul style="list-style-type: none"> – Activation of sensors with external power supply – The external temperature sensor at E4/5 does not require an external power supply. When connecting an analogue external sensor, the 0 to 10 V or the 1 to 10 V must be supplied from the sensor. – Binary input power supply: supplied by the device. 	1 to 10 V / 0 to 10 V + external temperature sensor DP4-T-1 (alternatively PT1000)
c) 5 binary inputs	
Display values <ul style="list-style-type: none"> ▪ Temperature: 	0°C to 35°C
Nominal current:	< 9 mA

Designation	Value
Mode of operation (DIN EN 60730-1)	See operating instructions
Degree of contamination (DIN EN 60730-1)	See operating instructions
Rated surge voltage (DIN EN 60730-1)	See operating instructions

Table 2: Technical data

6 Connection, installation / mounting



Danger - Electric voltage!

Install the device only if you have the necessary electrical engineering knowledge and experience.

- Incorrect installation endangers your life and that of the users of the electrical system.
- Incorrect installation can cause serious damage to property, e.g. due to fire.

The minimum necessary expert knowledge and requirements for the installation are as follows:

- Apply the "five safety rules" (DIN VDE 0105, EN 50110):
 1. Disconnect
 2. Secure against being re-connected
 3. Ensure there is no voltage
 4. Connect to earth and short-circuit
 5. Cover or barricade adjacent live parts.
- Use suitable personal protective clothing.
- Use only suitable tools and measuring devices.
- Check the type of supply network (TN system, IT system, TT system) to secure the following power supply conditions (classic connection to ground, protective earthing, necessary additional measures, etc.).
- Observe the correct polarity.

6.1 Installation site

For proper commissioning please observe the following points:

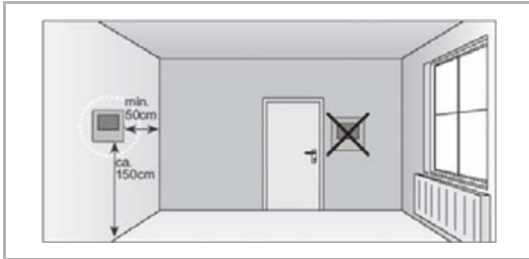

Fig. 1: Installation site - Distance

- The device should be installed at a height of approximately 150 cm from the floor and 50 cm from a door frame.

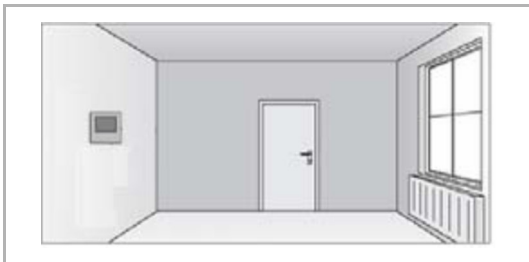

Fig. 2: Installation site – Position of radiator

- The device should be installed on a wall opposite a radiator.

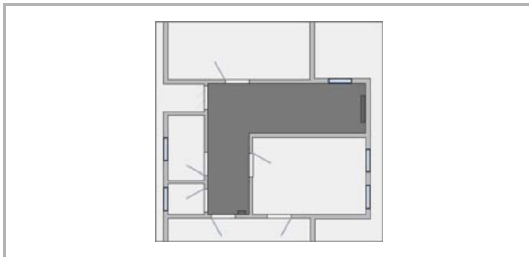

Fig. 3: Installation site - Room architecture

- The angles of the room architecture should not separate a radiator and the device from each other.

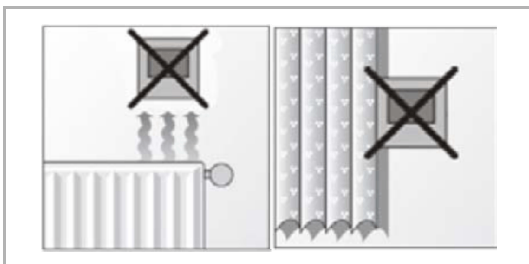

Fig. 4: Installation site – Position of RTC

- Installing a device close to a radiator or behind curtains is not practical.



Fig. 5: Installation site - Exterior wall

- This also applies to installation on an exterior wall.
 - Low outside temperatures have an effect on temperature regulation.

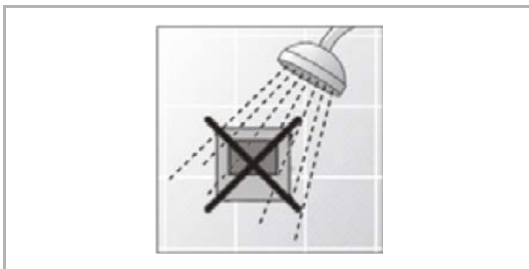

Fig. 6: Installation site – Wetting with fluids

- Wetting the room temperature controller with fluids is to be avoided.

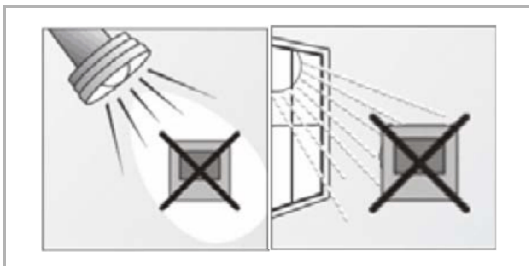

Fig. 7: Installation site – Direct sunlight

- Just as heat radiated from electric loads can impair the temperature regulation, so can direct sunlight on the device.

6.2 Mounting



Caution! The device can sustain damage when coming into contact with hard objects!

The plastic parts of the device are sensitive.

- Pull the attachment off only with your hands.
- Do not lever parts off with screwdrivers or similar hard objects.

The flush-mounted insert must only be installed in flush-mounted wall boxes according to DIN 49073-1, Part 1, or suitable surface-mounted housings.

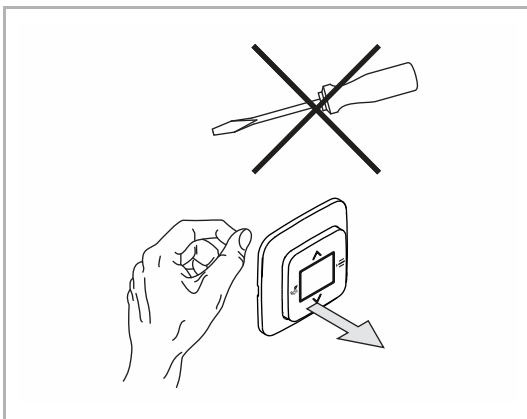

Fig. 8: Wall mounting: pulling off the attachment

- If the device is already mounted or assembled, pull the attachment off the flush-mounted insert with the aid of the cover frame.

To install the device, perform the following steps:

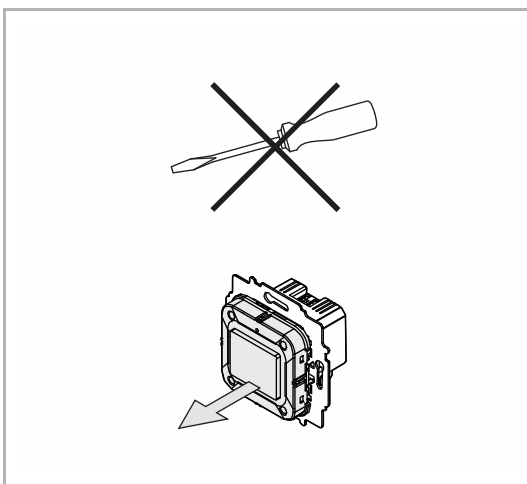

Fig. 9: Device in as-delivered state: pulling off the attachment

- If the device is in its as-delivered state, pull the attachment off the flush-mounted insert with your hands.
- Pull the attachment off only with your hands!
- Do not lever parts off with screwdrivers or similar hard objects. This will damage the device.
- When pulling off, first the resistance of the spring clamps must be overcome.

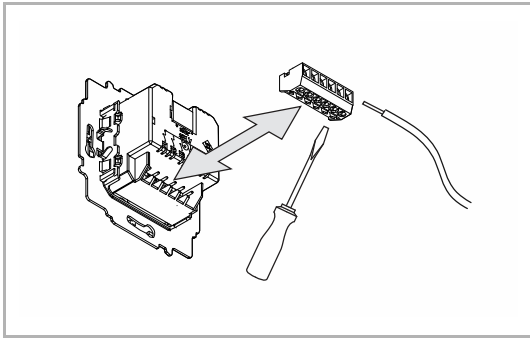

Fig. 10: Connecting the cables

1. Connect the cables to the flush-mounted insert.
 - The device clamp block can be pulled off the device to make it easier to establish the electrical connection.
 - For the connection assignment, see chapter 6.3 “Electrical connection” on page 24.

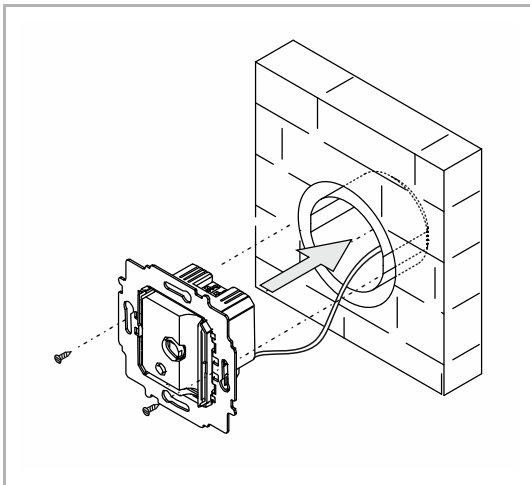

Fig. 11: Mounting the flush-mounted insert

2. Mount the flush-mounted insert.

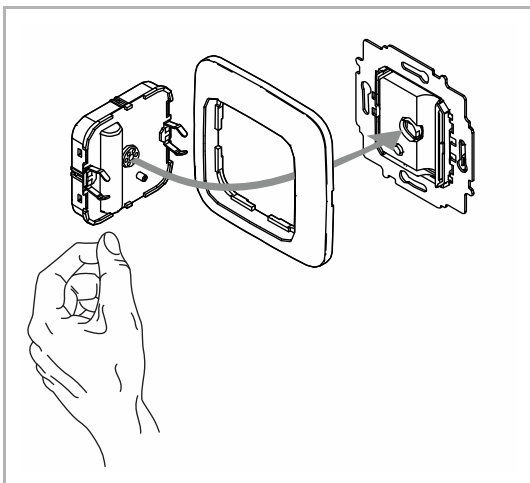

Fig. 12: Mounting the attachment

3. Plug the attachment together with the cover frame onto the flush-mounted insert.
 - Ensure that the plug-in connection on the rear side does not get jammed.
 - If mounting is difficult, check whether a burr has formed at the lock-in openings of the flush-mounted insert and remove it.

The device is now mounted.

6.3 Electrical connection

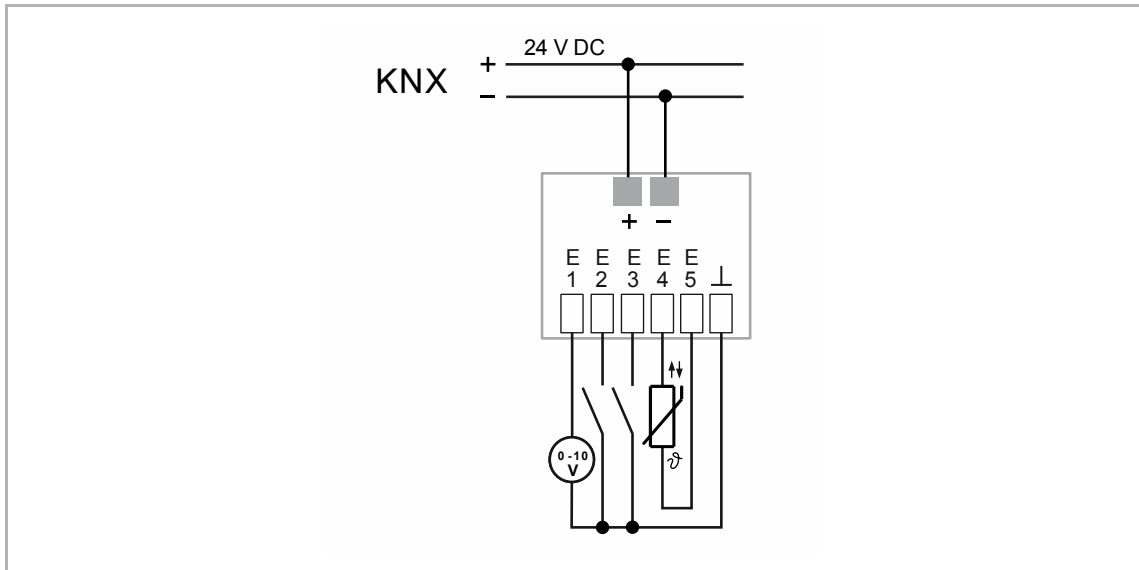

Fig. 13: Electrical connection

Terminal	Binary	Temperature sensor	0 to 10 V	1 to 10 V
E1	X	—	X	X
E2	X	—	—	—
E3	X	—	—	—
E4	X	X	—	—
E5	X		—	—
E6 (GND)	—	—	—	—

Tab. 3: Possible functions of the universal inputs

7 Commissioning

To start the device a physical address must be assigned first. The physical address is assigned and the parameters are set with the Engineering Tool Software (ETS).



NOTE

The devices are products of the KNX system and meet KNX guidelines. Detailed expert knowledge by means of KNX training sessions for a better understanding is assumed.

7.1.1 Preparation

1. Connect a PC to the KNX bus line via the KNX interface, e.g. via the commissioning interface / the commissioning adapter 6149/21-500).
 - The current Engineering Tool Software must be installed on the PC (ETS 4.2 or higher).
2. Switch on the bus voltage.

7.1.2 Assigning a physical address

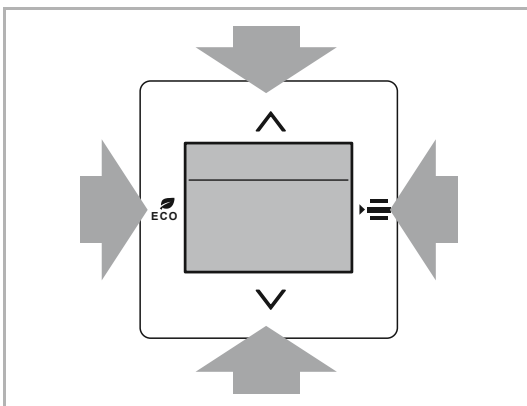

Fig. 14: Assigning a physical address

Use the following steps to switch to programming mode:

1. Press all buttons simultaneously for at least 5 seconds.
 - The red display illumination becomes active.
 - Display: physical address input

7.1.3 Assigning the group address(es)

The group addresses are assigned in connection with the ETS.

7.1.4 Selecting the application program

Please contact our Internet support unit (www.BUSCH-JAEGER.com). The application is loaded into the device via the ETS.

7.1.5 Differentiating the application program

Various functions can be implemented via the ETS.

Detailed description of parameters, see chapter 10 “Description of application and parameters“ on page 35.

8 Operation

The room temperature controller is operated via the button elements of the cover plate.

The precise function is fixed via the device application and its parameter settings.

An extensive range of parameters is available in the application. For information on how to make parameter settings, see Chapter Chapter 10.1 “Application program“ on page 35.



NOTE

In the basic setting the display always indicates the setpoint temperature!

8.1 Control elements

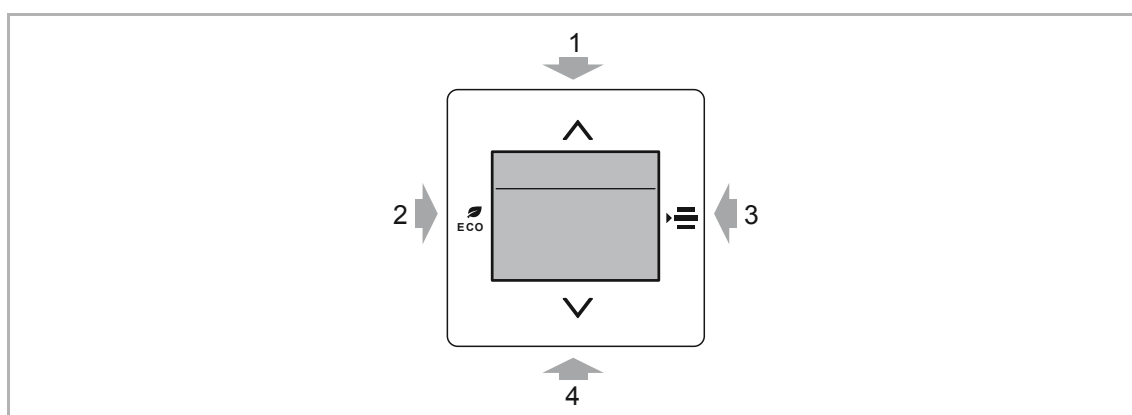

Fig. 15: Control elements

- [1] UP button
Increase value/go back one menu item
Change/activate menu item if parameterized
- [2] ECO button
(press to switch to ECO mode)
- [3] MENU button
Selection of one of the following functions in the sequence of the list.
Prerequisite: The parameters for the functions have been set beforehand.
 - Primary function with manual setpoint adjustment (default display)
 - Fan speed levels (manual fan speed level adjustment)
 - Off/On (manual activation/deactivation of automatic control function)
 - Heating/cooling switching (manual switching between heating and cooling)
- [4] DOWN button
Reduce value/go forward one menu item
Change/activate menu item if parameterized



NOTE

- The default display (primary function) of the device always shows the setpoint temperature. This can be changed via the arrow buttons of the control element.
- The scope of supply only contains the flush-mounted insert and the flush-mounted control element. It is necessary to order the matching cover plate and a cover frame separately. Additional information about the switch ranges is available in the electronic catalogue (www.busch-jaeger-catalogue.com).

8.2 Displays / messages

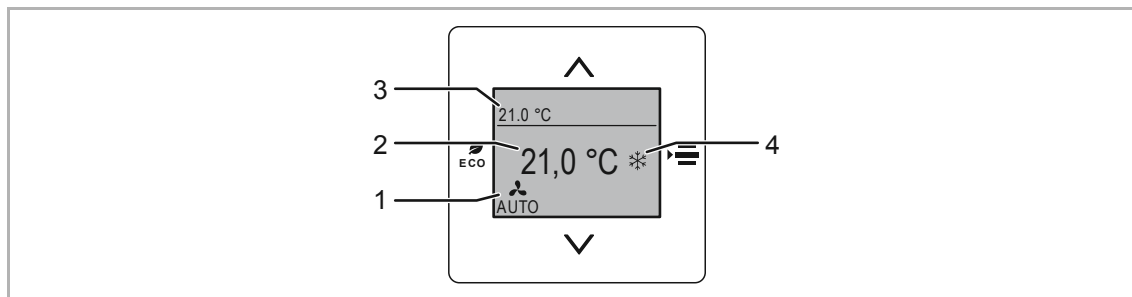

Fig. 16: Primary function display

- [1] Current fan speed level (if parameterized)
- [2] Setpoint temperature (required temperature)
- [3] Current temperature
- [4] Active operating mode: heating and/or cooling



NOTE

Some of the functions shown here are only displayed if the parameters for them have been set beforehand using the ETS Tool Software.

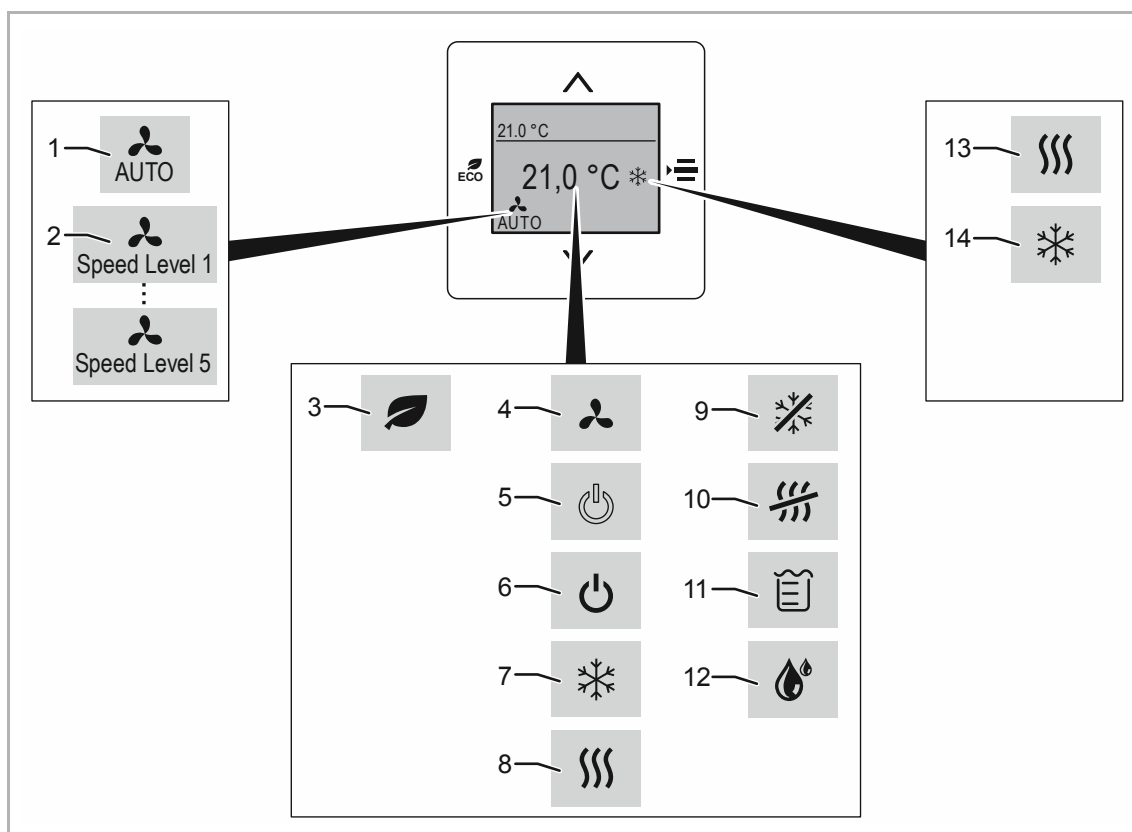
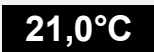













Fig. 17: Icons displayed

No.	Meaning	Function
[1]	Display	Automatic fan control
[2]	Display	Manual fan control (speeds 1 to 5)
[3]	Display	ECO mode active
[4]	Setting	Fan speed levels In this mode, the icon is only shown in conjunction with the active fan speed level.
[5]	Setting	ON Device is active (ON)
[6]	Setting	OFF Device is switched off (frost protection active)
[7]	Setting	Cooling
[8]	Setting	Heating
[9]	Message	Frost protection
[10]	Message	Heat protection
[11]	Message	Condensate
[12]	Message	Dew point
[13]	Display	Heating active
[14]	Display	Cooling active

8.3 Operating modes and alarms

The device has the following operating modes:

Display	Operating mode
	<p>Standard operation</p> <ul style="list-style-type: none"> – The display shows the setpoint temperature that has been set. The controller aims at this temperature. – Application: You are in the room for a longer period of time; the comfort temperature is to be reached.
	<p>ECO mode</p> <ul style="list-style-type: none"> – The room temperature is reduced by the parameterized temperature value. – Application: You are leaving the room for a few hours; the room temperature is to be reduced to save energy. However, the room should not cool down completely.
	<p>OFF mode</p> <ul style="list-style-type: none"> – The device can be activated and deactivated. When the controller is deactivated, this icon appears on the display. The device operates in frost protection mode. – Application: The room is not being used for a longer period of time.
	<p>Frost protection:</p> <ul style="list-style-type: none"> – If parameterized, frost protection will ensure that the temperature does not drop below the desired value. It is the lowest setpoint.
	<p>Heat protection:</p> <ul style="list-style-type: none"> – If parameterized, heat protection will ensure that the temperature does not exceed the desired value. It is the highest setpoint. – Anwendung: Ein Fenster im Raum wird geöffnet. Hierzu muss das Fenster über entsprechende Kontakte verfügen.
 	<p>Heating/cooling switchover</p> <ul style="list-style-type: none"> – The device operates in heating mode. The display shows the icon for heating. The settings for heating mode are available. – Application: The device is suitable for both heating and cooling mode. Switchover between these two operating modes takes place either automatically via a binary input which has been configured as a heating/cooling reverser, or manually using the "Heating/Cooling" menu.
	<p>Dew point:</p> <ul style="list-style-type: none"> – If an appropriate telegram is received from a dew point sensor, the room temperature controller will display the corresponding icon and cease cooling, instead merely protecting against the heat.
	<p>Condensate:</p> <ul style="list-style-type: none"> – The operation of a fan coil may cause condensate water, which is collected in a container. If the fan coil sends out a telegram when the container is full, the icon for condensate mode is displayed. The room temperature controller switches automatically to heat protection mode.
  	<p>Fan operation</p> <ul style="list-style-type: none"> – When the fan is being controlled manually, the display shows one of the speed levels, "1" to "5". – The display shows "Auto" when the fan is being controlled automatically. – Application: You want to change the automatically selected fan speed level and set the desired fan speed level manually on the device. The control of the temperature in the room continues to be active.

8.4 Setting operating modes/functions

8.4.1 Setting the setpoint temperature (required temperature)

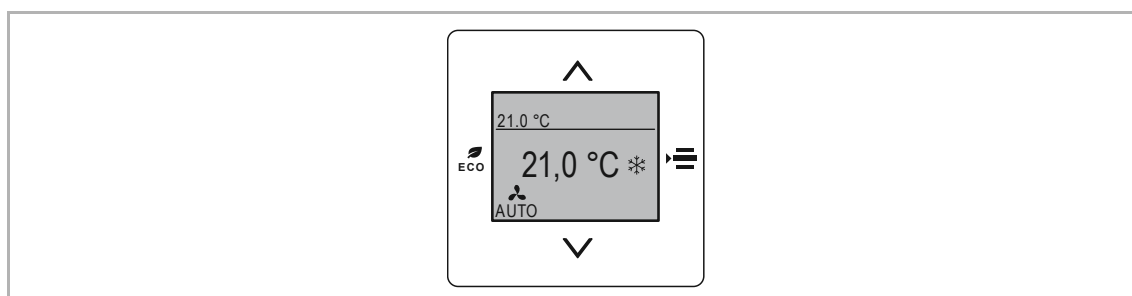

Fig. 18: Setting the setpoint temperature (required temperature)

The setpoint temperature appears automatically on the display. The device must be switched on for this to happen.

Setting the setpoint temperature

Set the setpoint temperature using the UP and DOWN buttons. The setpoint temperature that is currently set appears on the display.

- Press the UP button to increase the setpoint temperature.
- Press the DOWN button to reduce the setpoint temperature.

The new setpoint temperature is displayed.

8.4.2 Eco mode

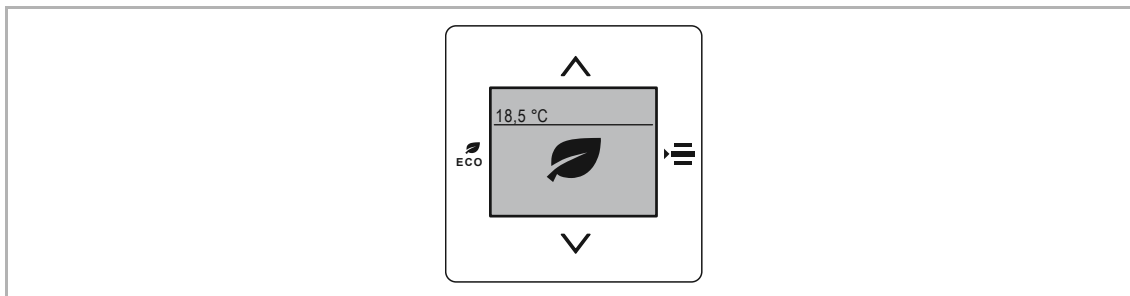

Fig. 19: ECO mode

ECO mode is used to reduce the room temperature automatically and to reduce the fan speed level, if this option has been parameterized. As a result, less energy is consumed when the occupants are absent, for example.

Activating ECO mode

1. Press the ECO button.
 - The device switches to ECO mode.

Deactivating ECO mode

2. Press any button.
 - The device switches back to standard operation.



NOTE

The function of ECO mode is set via the "RTC" and "Control settings" applications.

The default setting cannot be changed via the setpoint adjustment (UP and DOWN buttons).

8.4.3 Switching On and Off

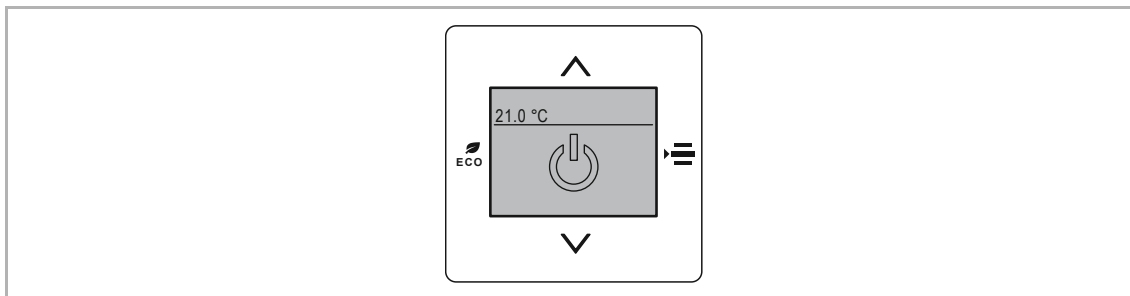

Fig. 20: ON/OFF

The device operates in frost/heat protection mode when switched off.

Switching off (deactivating)

1. Press the MENU button until the "ON/OFF" function appears.
 - The "ON" icon is shown in a frame.
2. Use the UP or DOWN button to switch to the "OFF" function.
 - The "OFF" icon is shown in full.
 - Frost/heat protection is activated.

Switching on (activating)

- The "OFF" icon is shown in full.
1. Press the UP/DOWN button.
 - The "ON" icon is shown in a frame.
 - The device switches to the setpoint display (comfort mode).



NOTE

Local operation is disabled when the device is OFF, in frost/heat protection mode, in dew point mode and in condensate mode. The disabled function is also indicated by the corresponding disabled icon on the display.

8.4.4 Adjusting the fan speed levels

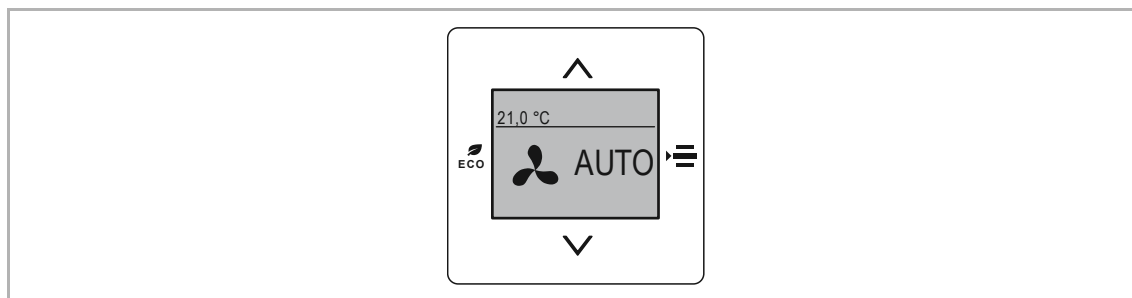

Fig. 21: Fan setting

Selecting the fan speed level

1. Press the MENU button until the "Fan" function appears.
2. Use the UP or DOWN button to switch between the fan settings.
 - 5 speed levels are available to select for the manual fan setting.
 - If "AUTO" is selected, the device control system will take on the task of determining the fan speed level.
 - After a few seconds, the display will switch back to its default mode.
 - The fan speed level that is set is stored automatically.
 - The fan speed level that is set is shown on the display.



NOTE

The function of the fan speed levels is adjusted in application "RTC". This function is inactive if "Fan coil" has not been parameterized.

8.4.5 Changing the operating status (heating/cooling)

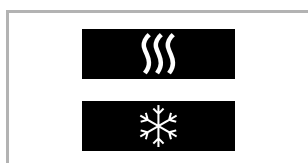

Fig. 22: Heating/cooling operating mode

1. Keep the button [3] pressed until the display flashes.
2. Keep pressing the MENU button until the heating or cooling icon appears on the display.
3. Press the UP/DOWN button to adjust the operating mode.
 - The selected operating mode is adopted when a timeout happens after nothing has been pressed for a certain period of time, or if the MENU button is pressed again.
 - The set operating mode appears on the display to the right of the setpoint (comfort mode).

When the "Heating" and/or "Cooling" control function is activated, the operating mode that is currently set is indicated on the display.

9 Maintenance

9.1 Cleaning

**Caution! - Risk of damaging the device!**

- When spraying on cleaning agents, these can enter the device through crevices.
 - Do not spray cleaning agents directly onto the device.
- Aggressive cleaning agents can damage the surface of the device.
 - Never use caustic agents, abrasive agents or solvents.

Clean dirty devices with a soft dry cloth.

- If this is insufficient, the cloth can be moistened slightly with a soap solution.

10 Description of application and parameters

10.1 Application program

The following application program is available:

Application program
6109/18-500: Room temperature controller with universal input, 5gang

The application program for the room temperature controller contains the applications listed in the following:

KNX application
Control settings
Button top right
General functions
Global settings
RTC
Inputs
Temperature
Dew point

Depending on which device and application are selected, the Engineering Tool Software "ETS" shows different parameters and communication objects. This allows the control element to be set accordingly with multi functions.

10.2 Communication objects – Room air sensor

10.2.1 Send "0" in operation

Number	Name	Object function	Data type (DPT)
1	Send "0" in operation	Output	Bool

The communication object reports a device defect to the bus with the value "1". This cyclical telegram can be monitored with an external device. If no telegram is received, the device may be defective or the bus line to the sending device may have been interrupted.

10.2.2 Send "1" in operation

Number	Name	Object function	Data type (DPT)
2	Send "1" in operation	Output	Bool

The communication object reports the presence of the device to the bus with the value "1". This cyclical telegram can be monitored with an external device.

10.2.3 MC – Main counter reading

Number	Name	Object function	Data type
	MC: Main counter reading		

This parameter defines the data type of the main counter.

The parameter depends on the "Data type" parameter. Different limit values are preset according to the data type that is selected. The input fields can be freely edited. The following object types are available to select for the main counter data type:

Options:	8-bit value [-128 to 127]
	8-bit value [0 to 255]
	16-bit value [-32,768 to 32,767]
	16-bit value [0 to 65,535]
	32-bit value [-2,147,485,648 to 2,147,483,647]

10.2.4 Request status

Number	Name	Object function	Data type (DPT)
3	Request status	Input	Switch

If a telegram with the value x ($x = 0/1/0$ or 1) is received at this communication object, all the status objects are sent to the bus provided they have been parameterized with the option for changing or requesting.

In the case of the option $x = 1$, all the status messages are sent provided they have been parameterized with the option for changing or requesting

In the case of the option $x = 0$, there is no reaction.

10.2.5 E1 – 1-byte value (-128 to 127)

Number	Name	Object function	Data type (DPT)
185	E1: 1-byte value (-128 to 127)	Output	Value_1_Count

The output sends a defined 1-byte value to the KNX bus.

10.2.6 E1 – 1-byte value (0 to 255)

Number	Name	Object function	Data type (DPT)
186	E1: 1-byte value (0 to 255)	Output	Value_1_Ucount

The output sends a defined 1-byte value to the KNX bus.

10.2.7 E1 – 2-byte value (-32,768 to 32,767)

Number	Name	Object function	Data type (DPT)
187	E1: 2-byte value (-32,768 to 32,767)	Output	Value_2_Count

The output sends a defined 2-byte value to the KNX bus.

10.2.8 E1 – 2-byte value (0 to 65,535)

Number	Name	Object function	Data type (DPT)
188	E1 2-byte value (0 to 65,535)	Output	Value_2_Ucount

The output sends a defined 2-byte value to the KNX bus.

10.2.9 E1 – 2-byte floating point

Number	Name	Object function	Data type (DPT)
189	E1: 2-byte floating point	Output	Value_Temp

The output sends a defined 2-byte value to the KNX bus.

10.2.10 E1 – 4-byte floating point

Number	Name	Object function	Data type (DPT)
190	E1: 4-byte floating point	Output	Value_Acceleration

The output sends a defined 4-byte value to the KNX bus.

10.2.11 E1 – Request

Number	Name	Object function	Data type (DPT)
191	E1: Request	Output	Switch

The current value can be read/requested via the KNX bus.

10.2.12 E1 – Outside of range

Number	Name	Object function	Data type (DPT)
192	E1: Outside of range	Output	Switch

The output sends when the measured value is outside the parameterized range.

10.2.13 E1 – Change threshold, tolerance band upper limit

Number	Name	Object function	Data type (DPT)
194	E1: Change threshold, tolerance band upper limit	Input	Scaling

Using this communication object, the upper limit of the threshold can be set via the corresponding object.

The changes made are not visible in the ETS application. They may need to be made again using this communication object after an application download.

10.2.14 E1 – Change threshold, tolerance band lower limit

Number	Name	Object function	Data type (DPT)
193	E1: Change threshold, tolerance band lower limit	Input	Scaling

Using this communication object, the lower limit of the threshold can be set via the corresponding object.

The changes made are not visible in the ETS application. They may need to be made again using this communication object after an application download.

10.2.15 E1 – Threshold value

Number	Name	Object function	Data type (DPT)
195	E1: Threshold value	Output	Switch
196		Output	Value_1_Ucount
197		Output	Value_2_Ucount
198		Output	Value_Temp

The value sent via the object is parameterized in the application. This parameterized value is sent to the KNX bus after the threshold is exceeded.

10.2.16 E1 – Send if threshold value undershot

Number	Name	Object function	Data type (DPT)
199	E1: Send if threshold value undershot	Input	Value_1_Ucount
200		Input	Value_1_Ucount
201		Input	Value_2_Ucount
202		Input	Value_2_Ucount
203		Input	Value_Temp
204		Input	Value_Temp

If the parameterized threshold value is undershot, the value that is undershot is sent to the KNX bus.

10.2.17 E1-E5 – Alarm sensor

Number	Name	Object function	Data type (DPT)
116	E1: Alarm sensor	Output	Alarm
207	E2: Alarm sensor	Output	Alarm
277	E3: Alarm sensor	Output	Alarm
347	E4: Alarm sensor	Output	Alarm
450	E5: Alarm sensor	Output	Alarm

The parameter enables a defined 1-bit alarm telegram to be sent out.

10.2.18 E1-E5 – Scene storage display

Number	Name	Object function	Data type (DPT)
151	E1: Scene storage display	Output	Enable
242	E2: Scene storage display	Output	Enable
312	E3: Scene storage display	Output	Enable
382	E4: Scene storage display	Output	Enable
485	E5: Scene storage display	Output	Enable

If a storage command is sent via the light scenes to the actuator channels incorporated into the scene, the object provides this status to the KNX bus.

If the object is linked to the object of a KNX control element, for example, the storage process may be visualised by the status LED flashing.

10.2.19 E1-E5 – Actuating number

Number	Name	Object function	Data type (DPT)
159	E1: Actuating number	Input	Value_1_Ucount
250	E2: Actuating number	Input	Value_1_Ucount
320	E3: Actuating number	Input	Value_1_Ucount
390	E4: Actuating number	Input	Value_1_Ucount
493	E5: Actuating number	Input	Value_1_Ucount

With this object, it is possible to affect manual adjustment of the switching sequences by specifying a switching level via the KNX bus.

10.2.20 E1-E5 – Dimming

Number	Name	Object function	Data type (DPT)
120	E1: Dimming	Output	Control_Dimming
211	E2: Dimming	Output	Control_Dimming
281	E3: Dimming	Output	Control_Dimming
351	E4: Dimming	Output	Control_Dimming
454	E5: Dimming	Output	Control_Dimming

The object is used to send the appropriate hexadecimal value for ON/OFF dimming to the KNX bus via the output or the corresponding KNX object.

10.2.21 E1-E5 – Bottom end position

Number	Name	Object function	Data type (DPT)
125	E1: Bottom end position	Output	Bool
216	E2: Bottom end position	Output	Bool
286	E3: Bottom end position	Output	Bool
356	E4: Bottom end position	Output	Bool
459	E5: Bottom end position	Output	Bool

If the actuator being used has a corresponding communication object that detects the bottom end position of the blind or roller shutter, it is possible to link this information to the binary input.

With this information, the "Move blind up" action is executed each time this application is actuated.

10.2.22 E1-E5 – Top end position

Number	Name	Object function	Data type (DPT)
124	E1: Top end position	Output	Bool
215	E2: Top end position	Output	Bool
285	E3: Top end position	Output	Bool
355	E4: Top end position	Output	Bool
458	E5: Top end position	Output	Bool

If the actuator being used has a corresponding communication object that detects the top end position of the blind or roller shutter, it is possible to link this information to the binary input.

With this information, the "Move blind down" action is executed each time this application is actuated.

10.2.23 E1-E5 – Start event 0/1

Number	Name	Object function	Data type (DPT)
117	E1: Start event 0/1	Input	Switch
208	E2: Start event 0/1	Input	Switch
278	E3: Start event 0/1	Input	Switch
348	E4: Start event 0/1	Input	Switch
451	E5: Start event 0/1	Input	Switch

With this object, it is possible to trigger the same events as the buttons/switches connected to the binary input by receiving a telegram at the "Start event 0/1" communication object.

This application does not take into account any minimum signal duration that is set or any distinction between a short and long pressing duration; in other words, the event is executed immediately.

10.2.24 E1-E5 – Blind UP/DOWN

Number	Name	Object function	Data type (DPT)
122	E1: Blind UP/DOWN	Output	UpDown
213	E2: Blind UP/DOWN	Output	UpDown
283	E3: Blind UP/DOWN	Output	UpDown
353	E4: Blind UP/DOWN	Output	UpDown
456	E5: Blind UP/DOWN	Output	UpDown

It is possible to use the input to move the blind/roller shutter up or down alternately.

10.2.25 E1-E5 – Priority (event 0)

Number	Name	Object function	Data type (DPT)
129	E1: Priority (event 0)	Output	Switch_Control
220	E2: Priority (event 0)	Output	Switch_Control
290	E3: Priority (event 0)	Output	Switch_Control
360	E4: Priority (event 0)	Output	Switch_Control
463	E5: Priority (event 0)	Output	Switch_Control

The output sends a priority 2-bit object to the KNX bus.

10.2.26 E1-E5 – Priority (event 1)

Number	Name	Object function	Data type (DPT)
130	E1: Priority (event 1)	Output	Switch_Control
221	E2: Priority (event 1)	Output	Switch_Control
291	E3: Priority (event 1)	Output	Switch_Control
361	E4: Priority (event 1)	Output	Switch_Control
464	E5: Priority (event 1)	Output	Switch_Control

The output sends a priority 2-bit object to the KNX bus.

10.2.27 E1-E5 – STOP/slat adjustment

Number	Name	Object function	Data type (DPT)
123	E1: STOP/slat adjustment	Output	Step
214	E2: STOP/slat adjustment	Output	Step
284	E3: STOP/slat adjustment	Output	Step
354	E4: STOP/slat adjustment	Output	Step
457	E5: STOP/slat adjustment	Output	Step

The object is used to send the appropriate 1-bit value for stopping or adjusting the slats to the KNX bus via the output or the corresponding KNX object.

The value "0" or "1" is sent alternately during the process.

10.2.28 E1-E5 – 2-byte floating point (event 0)

Number	Name	Object function	Data type (DPT)
145	E1: 2-byte floating point (event 0)	Output	Value_Temp
236	E2: 2-byte floating point (event 0)	Output	Value_Temp
306	E3: 2-byte floating point (event 0)	Output	Value_Temp
376	E4: 2-byte floating point (event 0)	Output	Value_Temp
479	E5: 2-byte floating point (event 0)	Output	Value_Temp

The value "0" of the 2-byte value is available at the communication object.

10.2.29 E1-E5 – 2-byte floating point (event 1)

Number	Name	Object function	Data type (DPT)
146	E1: 2-byte floating point (event 1)	Output	Value_Temp
237	E2: 2-byte floating point (event 1)	Output	Value_Temp
307	E3: 2-byte floating point (event 1)	Output	Value_Temp
377	E4: 2-byte floating point (event 1)	Output	Value_Temp
480	E5: 2-byte floating point (event 1)	Output	Value_Temp

The parameter transfers the intermediate counter value to the KNX bus in the form of a 2-byte value.

10.2.30 E1-E5 – Switch (event 0)

Number	Name	Object function	Data type (DPT)
127	E1: Switch (event 0)	Output	Switch
218	E2: Switch (event 0)	Output	Switch
288	E3: Switch (event 0)	Output	Switch
358	E4: Switch (event 0)	Output	Switch
461	E5: Switch (event 0)	Output	Switch

The output sends the value "0" or "1" to the KNX bus alternately.

10.2.31 E1-E5 – Switch (event 1)

Number	Name	Object function	Data type (DPT)
128	E1: Switch (event 1)	Output	Switch
219	E2: Switch (event 1)	Output	Switch
289	E3: Switch (event 1)	Output	Switch
359	E4: Switch (event 1)	Output	Switch
462	E5: Switch (event 1)	Output	Switch

The output sends the value "0" or "1" to the KNX bus alternately.

10.2.32 E1-E5 – Switching sensor

Number	Name	Object function	Data type (DPT)
115	E1: Switching sensor	Output	Switch
206	E2: Switching sensor	Output	Switch
276	E3: Switching sensor	Output	Switch
346	E4: Switching sensor	Output	Switch
449	E5: Switching sensor	Output	Switch

It is possible to use the input to move the blind/roller shutter up or down alternately.

10.2.33 E1-E5 – Enable save

Number	Name	Object function	Data type (DPT)
150	E1: Enable save	Input	Enable
241	E2: Enable save	Input	Enable
311	E3: Enable save	Input	Enable
381	E4: Enable save	Input	Enable
484	E5: Enable save	Input	Enable

The communication object can be used to save the value that is present at the output.

10.2.34 E1-E5 – Disable

Number	Name	Object function	Data type (DPT)
118, 121, 126, 147, 152, 160, 166, 184, 205	E1: Disable	Input	Enable
209, 212, 217, 238, 243, 251, 257, 275	E2: Disable	Input	Enable
279, 282, 287, 308, 313, 321, 327, 345	E3: Disable	Input	Enable
349, 352, 357, 378, 383, 391, 397, 414, 415, 421	E4: Disable	Input	Enable
452, 455, 460, 481, 486, 494, 500, 518	E5: Disable	Input	Enable

When the value "1" is received at the object, the parameterized function is completely disabled.

It is then enabled when the value "0" is received. Only then will it be possible for the input objects to communicate on the KNX bus again.

10.2.35 E1-E5 – Switch step up/down

Number	Name	Object function	Data type (DPT)
158	E1: Switch step up/down	Input	Switch
249	E2: Switch step up/down	Input	Switch
319	E3: Switch step up/down	Input	Switch
389	E4: Switch step up/down	Input	Switch
492	E5: Switch step up/down	Input	Switch

This KNX object makes it possible to switch the actuation direction of the "Step switch" application.

10.2.36 E1-E5 – Scene

Number	Name	Object function	Data type (DPT)
148	E1: Scene	Output	SceneControl
239	E2: Scene	Output	SceneControl
309	E3: Scene	Output	SceneControl
379	E4: Scene	Output	SceneControl
482	E5: Scene	Output	SceneControl

The object can be used to retrieve one of 64 scenes via a 1-byte value.

10.2.37 E1-E5 – Scene (event 0)

Number	Name	Object function	Data type (DPT)
135	E1: Scene (event 0)	Output	SceneControl
226	E2: Scene (event 0)	Output	SceneControl
296	E3: Scene (event 0)	Output	SceneControl
366	E4: Scene (event 0)	Output	SceneControl
469	E5: Scene (event 0)	Output	SceneControl

The scene with value "0" is not used.

10.2.38 E1-E5 – Scene (event 1)

Number	Name	Object function	Data type (DPT)
136	E1: Scene (event 1)	Output	SceneControl
227	E2: Scene (event 1)	Output	SceneControl
297	E3: Scene (event 1)	Output	SceneControl
367	E4: Scene (event 1)	Output	SceneControl
470	E5: Scene (event 1)	Output	SceneControl

The object can be used to retrieve one of 64 scenes via a 1-byte value.

10.2.39 E1-E5 – Save scene

Number	Name	Object function	Data type (DPT)
149	E1: Save scene	Input	Enable
240	E2: Save scene	Input	Enable
310	E3: Save scene	Input	Enable
380	E4: Save scene	Input	Enable
483	E5: Save scene	Input	Enable

Actuating the save request causes the value settings in the scene to be read out and stored in the scene module.



NOTE

The device only has one scene extension unit function. A corresponding scene actuator for managing/storing the required values must be located in another KNX device.

10.2.40 E1-E5 – Switching

Number	Name	Object function	Data type (DPT)
119	E1: Switching	Output	Switch
210	E2: Switching	Output	Switch
280	E3: Switching	Output	Switch
350	E4: Switching	Output	Switch
453	E5: Switching	Output	Switch

The output sends the value "0" or "1" to the KNX bus alternately.

10.2.41 E1-E5 – Switching – 1 actuation

Number	Name	Object function	Data type (DPT)
161	E1: Switching 1 actuation	Output	Switch
252	E2: Switching 1 actuation	Output	Switch
322	E3: Switching 1 actuation	Output	Switch
392	E4: Switching 1 actuation	Output	Switch
495	E5: Switching 1 actuation	Output	Switch

The parameter sends the corresponding value "1" or "0" to the KNX bus.

10.2.42 E1-E5 – Switching – 2 actuations

Number	Name	Object function	Data type (DPT)
162	E1: Switching 2 actuations	Output	Switch
253	E2: Switching 2 actuations	Output	Switch
323	E3: Switching 2 actuations	Output	Switch
393	E4: Switching 2 actuations	Output	Switch
496	E5: Switching 2 actuations	Output	Switch

The second step of the multifunction is sent to the KNX bus with the parameterized value.

10.2.43 E1-E5 – Switching – 3 actuations

Number	Name	Object function	Data type (DPT)
163	E1: Switching 3 actuations	Output	Switch
254	E2: Switching 3 actuations	Output	Switch
324	E3: Switching 3 actuations	Output	Switch
394	E4: Switching 3 actuations	Output	Switch
497	E5: Switching 3 actuations	Output	Switch

The third step of the multifunction is sent to the KNX bus with the parameterized value.

10.2.44 E1-E5 – Switching – 4 actuations

Number	Name	Object function	Data type (DPT)
164	E1: Switching 4 actuations	Output	Switch
255	E2: Switching 4 actuations	Output	Switch
325	E3: Switching 4 actuations	Output	Switch
395	E4: Switching 4 actuations	Output	Switch
498	E5: Switching 4 actuations	Output	Switch

The fourth step of the multifunction is sent to the KNX bus with the parameterized value.

10.2.45 E1-E5 – Switching – long actuation

Number	Name	Object function	Data type (DPT)
165	E1: Switching, long actuation	Output	Switch
256	E2: Switching, long actuation	Output	Switch
326	E3: Switching, long actuation	Output	Switch
396	E4: Switching, long actuation	Output	Switch
499	E5: Switching, long actuation	Output	Switch

After a long button press, the corresponding 1-bit value is sent to the KNX bus. The required duration of the button press can be parameterized in the ETC application.

10.2.46 E1-E5 – Switching – step 1

Number	Name	Object function	Data type (DPT)
153	E1: Switching step 1	Output	Switch
244	E2: Switching step 1	Output	Switch
314	E3: Switching step 1	Output	Switch
384	E4: Switching step 1	Output	Switch
487	E5: Switching step 1	Output	Switch

The first step of the step switch is sent to the KNX bus.

10.2.47 E1-E5 – Switching – step 2

Number	Name	Object function	Data type (DPT)
154	E1: Switching step 2	Output	Switch
245	E2: Switching step 2	Output	Switch
316	E3: Switching step 2	Output	Switch
385	E4: Switching step 2	Output	Switch
488	E5: Switching step 2	Output	Switch

The second step of the step switch is sent to the KNX bus.

10.2.48 E1-E5 – Switching – step 3

Number	Name	Object function	Data type (DPT)
155	E1: Switching step 3	Output	Switch
246	E2: Switching step 3	Output	Switch
316	E3: Switching step 3	Output	Switch
386	E4: Switching step 3	Output	Switch
489	E5: Switching step 3	Output	Switch

The third step of the step switch is sent to the KNX bus.

10.2.49 E1-E5 – Switching – step 4

Number	Name	Object function	Data type (DPT)
156	E1: Switching step 4	Output	Switch
247	E2: Switching step 4	Output	Switch
317	E3: Switching step 4	Output	Switch
387	E4: Switching step 4	Output	Switch
490	E5: Switching step 4	Output	Switch

The fourth step of the step switch is sent to the KNX bus.

10.2.50 E1-E5 – Switching – step 5

Number	Name	Object function	Data type (DPT)
157	E1: Switching step 5	Output	Switch
248	E2: Switching step 5	Output	Switch
318	E3: Switching step 5	Output	Switch
388	E4: Switching step 5	Output	Switch
491	E5: Switching step 5	Output	Switch

The fifth step of the step switch is sent to the KNX bus.

10.2.51 E1-E5 – 1-byte value – (-128 to 127) (event 0)

Number	Name	Object function	Data type (DPT)
131	E1: 1-byte value (-128 to 127) (event 0)	Output	Value_1_Count
222	E2: 1-byte value (-128 to 127) (event 0)	Output	Value_1_Count
292	E3: 1-byte value (-128 to 127) (event 0)	Output	Value_1_Count
362	E4: 1-byte value (-128 to 127) (event 0)	Output	Value_1_Count
465	E5: 1-byte value (-128 to 127) (event 0)	Output	Value_1_Count

The output transfers the value "0", as a result of the limit value, from the main counter to the KNX bus as a 1-byte value.

10.2.52 E1-E5 – 1-byte value – (-128 to 127) (event 1)

Number	Name	Object function	Data type (DPT)
132	E1: 1-byte value (-128 to 127) (event 1)	Output	Value_1_Count
223	E2: 1-byte value (-128 to 127) (event 1)	Output	Value_1_Count
293	E3: 1-byte value (-128 to 127) (event 1)	Output	Value_1_Count
363	E4: 1-byte value (-128 to 127) (event 1)	Output	Value_1_Count
466	E5: 1-byte value (-128 to 127) (event 1)	Output	Value_1_Count

The output transfers the intermediate counter value to the KNX bus in the form of a 1-byte value.

10.2.53 E1-E5 – 1-byte value – (0 to 255) (event 0)

Number	Name	Object function	Data type (DPT)
133	E1: 1-byte value (0 to 255) (event 0)	Output	Value_1_Ucount
224	E2: 1-byte value (0 to 255) (event 0)	Output	Value_1_Ucount
294	E3: 1-byte value (0 to 255) (event 0)	Output	Value_1_Ucount
364	E4: 1-byte value (0 to 255) (event 0)	Output	Value_1_Ucount
467	E5: 1-byte value (0 to 255) (event 0)	Output	Value_1_Ucount

The output transfers the value "0", as a result of the limit value, from the main counter to the KNX bus as a 1-byte value.

10.2.54 E1-E5 – 1-byte value – (0 to 255) (event 1)

Number	Name	Object function	Data type (DPT)
134	E1: 1-byte value (0 to 255) (event 1)	Output	Value_1_Ucount
225	E2: 1-byte value (0 to 255) (event 1)	Output	Value_1_Ucount
295	E3: 1-byte value (0 to 255) (event 1)	Output	Value_1_Ucount
365	E4: 1-byte value (0 to 255) (event 1)	Output	Value_1_Ucount
468	E5: 1-byte value (0 to 255) (event 1)	Output	Value_1_Ucount

The output transfers the intermediate counter value to the KNX bus in the form of a 1-byte value.

10.2.55 E1-E5 – 2-byte value – (-32,768 to 32,767) (event 0)

Number	Name	Object function	Data type (DPT)
137	E1: 2-byte value (-32,768 to 32,767) (event 0)	Output	Value_2_Count
228	E2: 2-byte value (-32,768 to 32,767) (event 0)	Output	Value_2_Count
298	E3: 2-byte value (-32,768 to 32,767) (event 0)	Output	Value_2_Count
368	E4: 2-byte value (-32,768 to 32,767) (event 0)	Output	Value_2_Count
471	E5: 2-byte value (-32,768 to 32,767) (event 0)	Output	Value_2_Count

The output transfers the value "0", as a result of the limit value, from the main counter to the KNX bus as a 2-byte value.

10.2.56 E1-E5 – 2-byte value – (-32,768 to 32,767) (event 1)

Number	Name	Object function	Data type (DPT)
138	E1: 2-byte value (-32,768 to 32,767) (event 1)	Output	Value_2_Count
229	E2: 2-byte value (-32,768 to 32,767) (event 1)	Output	Value_2_Count
299	E3: 2-byte value (-32,768 to 32,767) (event 1)	Output	Value_2_Count
369	E4: 2-byte value (-32,768 to 32,767) (event 1)	Output	Value_2_Count
472	E5: 2-byte value (-32,768 to 32,767) (event 1)	Output	Value_2_Count

The output transfers the intermediate counter value to the KNX bus in the form of a 2-byte value.

10.2.57 E1-E5 – 2-byte value – (0 to 65,535) (event 0)

Number	Name	Object function	Data type (DPT)
139	E1: 2-byte value (0 to 65,535) (event 0)	Output	Value_2_Ucount
230	E2: 2-byte value (0 to 65,535) (event 0)	Output	Value_2_Ucount
300	E3: 2-byte value (0 to 65,535) (event 0)	Output	Value_2_Ucount
370	E4: 2-byte value (0 to 65,535) (event 0)	Output	Value_2_Ucount
473	E5: 2-byte value (0 to 65,535) (event 0)	Output	Value_2_Ucount

The output transfers the value "0", as a result of the limit value, from the main counter to the KNX bus as a 2-byte value.

10.2.58 E1-E5 – 2-byte value – (0 to 65,535) (event 1)

Number	Name	Object function	Data type (DPT)
140	E1: 2-byte value (0 to 65,535) (event 1)	Output	Value_2_Ucount
231	E2: 2-byte value (0 to 65,535) (event 1)	Output	Value_2_Ucount
301	E3: 2-byte value (0 to 65,535) (event 1)	Output	Value_2_Ucount
371	E4: 2-byte value (0 to 65,535) (event 1)	Output	Value_2_Ucount
474	E5: 2-byte value (0 to 65,535) (event 1)	Output	Value_2_Ucount

The output transfers the intermediate counter value to the KNX bus in the form of a 2-byte value.

10.2.59 E1-E5 – 4-byte value – (-2,147,483,648 to 2,147,483,647) (event 0)

Number	Name	Object function	Data type (DPT)
141	E1: 4-byte value (-2,147,483,648 to 2,147,483,647) (event 0)	Output	Value_4_Ucount
232	E2: 4-byte value (-2,147,483,648 to 2,147,483,647) (event 0)	Output	Value_4_Ucount
302	E3: 4-byte value (-2,147,483,648 to 2,147,483,647) (event 0)	Output	Value_4_Ucount
372	E4: 4-byte value (-2,147,483,648 to 2,147,483,647) (event 0)	Output	Value_4_Ucount
475	E5: 4-byte value (-2,147,483,648 to 2,147,483,647) (event 0)	Output	Value_4_Ucount

The value "0" of the 4-byte value is available at the communication object.

10.2.60 E1-E5 – 4-byte value – (-2,147,483,648 to 2,147,483,647) (event 1)

Number	Name	Object function	Data type (DPT)
142	E1: 4-byte value (-2,147,483,648 to 2,147,483,647) (event 1)	Output	Value_4_Ucount
233	E2: 4-byte value (-2,147,483,648 to 2,147,483,647) (event 1)	Output	Value_4_Ucount
303	E3: 4-byte value (-2,147,483,648 to 2,147,483,647) (event 1)	Output	Value_4_Ucount
373	E4: 4-byte value (-2,147,483,648 to 2,147,483,647) (event 1)	Output	Value_4_Ucount
476	E5: 4-byte value (-2,147,483,648 to 2,147,483,647) (event 1)	Output	Value_4_Ucount

The output transfers the intermediate counter value to the KNX bus in the form of a 4-byte value.

10.2.61 E1-E5 – 4-byte value – (0 to 4,294,967,295) (event 0)

Number	Name	Object function	Data type (DPT)
143	E1: 4-byte value (0 to 4,294,967,295) (event 0)	Output	Value_4_Ucount
234	E2: 4-byte value (0 to 4,294,967,295) (event 0)	Output	Value_4_Ucount
304	E3: 4-byte value (0 to 4,294,967,295) (event 0)	Output	Value_4_Ucount
374	E4: 4-byte value (0 to 4,294,967,295) (event 0)	Output	Value_4_Ucount
477	E5: 4-byte value (0 to 4,294,967,295) (event 0)	Output	Value_4_Ucount

The value "0" of the 4-byte value is available at the communication object.

10.2.62 E1-E5 – 4-byte value – (0 to 4,294,967,295) (event 1)

Number	Name	Object function	Data type (DPT)
144	E1: 4-byte value (0 to 4,294,967,295) (event 1)	Output	Value_4_Ucount
235	E2: 4-byte value (0 to 4,294,967,295) (event 1)	Output	Value_4_Ucount
305	E3: 4-byte value (0 to 4,294,967,295) (event 1)	Output	Value_4_Ucount
375	E4: 4-byte value (0 to 4,294,967,295) (event 1)	Output	Value_4_Ucount
478	E5: 4-byte value (0 to 4,294,967,295) (event 1)	Output	Value_4_Ucount

The value "0" of the 4-byte value is available at the communication object.

10.2.63 E1-E5 – MC – Request counter reading

Number	Name	Object function	Data type (DPT)
177	E1 MC: Request counter reading	Input	Switch
268	E2 MC: Request counter reading	Input	Switch
338	E3 MC: Request counter reading	Input	Switch
408	E4 MC: Request counter reading	Input	Switch
511	E5 MC: Request counter reading	Input	Switch

The current reading of the main counter can be read/requested via the KNX bus.

10.2.64 E1-E5 – MC – Limit value exceeded

Number	Name	Object function	Data type (DPT)
178	E1 MC: Limit value exceeded	Output	Bool
269	E2 MC: Limit value exceeded	Output	Bool
339	E3 MC: Limit value exceeded	Output	Bool
409	E4 MC: Limit value exceeded	Output	Bool
512	E5 MC: Limit value exceeded	Output	Bool

If the parameterized limit value of the main counter is exceeded, the excess is sent to the KNX bus as a 1-bit value.

10.2.65 E1-E5 – MC – Counter reading 1-byte value

Number	Name	Object function	Data type (DPT)
167	E1 MC: Counter reading 1-byte value	Output	Value_1_Count
168			Value_1_Ucount
258	E2 MC: Counter reading 1-byte value	Output	Value_1_Count
259			Value_1_Ucount
328	E3 MC: Counter reading 1-byte value	Output	Value_1_Count
329			Value_1_Ucount
398	E4 MC: Counter reading 1-byte value	Output	Value_1_Count
399			Value_1_Ucount
501	E5 MC: Counter reading 1-byte value	Output	Value_1_Count
502			Value_1_Ucount

The output transfers the main counter value to the KNX bus in the form of a 1-byte value.

10.2.66 E1-E5 – MC – Counter reading 2-byte value

Number	Name	Object function	Data type (DPT)
169	E1 MC: Counter reading 2-byte value	Output	Value_2_Count
170			Value_2_Ucount
260	E2 MC: Counter reading 2-byte value	Output	Value_2_Count
261			Value_2_Ucount
330	E3 MC: Counter reading 2-byte value	Output	Value_2_Count
331			Value_2_Ucount
400	E4 MC: Counter reading 2-byte value	Output	Value_2_Count
401			Value_2_Ucount
503	E5 MC: Counter reading 2-byte value	Output	Value_2_Count
504			Value_2_Ucount

The output transfers the main counter value to the KNX bus in the form of a 2-byte value.

10.2.67 E1-E5 – MC – Counter reading 4-byte value

Number	Name	Object function	Data type (DPT)
171	E1 MC: Counter reading 4-byte value	Output	Value_4_Count
262	E2 MC: Counter reading 4-byte value	Output	Value_4_Count
332	E3 MC: Counter reading 4-byte value	Output	Value_4_Count
402	E4 MC: Counter reading 4-byte value	Output	Value_4_Count
505	E5 MC: Counter reading 4-byte value	Output	Value_4_Count

The output transfers the main counter value to the KNX bus in the form of a 4-byte value.

10.2.68 E1-E5 – IC – Stop

Number	Name	Object function	Data type (DPT)
183	E1 IC: Stop	Input	Bool
274	E2 IC: Stop	Input	Bool
344	E3 IC: Stop	Input	Bool
414	E4 IC: Stop	Input	Bool
517	E5 IC: Stop	Input	Bool

Via this object, the intermediate counter is stopped when the value "0" is received.

Any further incoming telegrams will not be counted.

The value "1" enables the intermediate counter again. Any telegrams that are received are included in the count.

10.2.69 E1-E5 – IC – Limit value exceeded

Number	Name	Object function	Data type (DPT)
179	E1 IC: Limit value exceeded	Output	Bool
270	E2 IC: Limit value exceeded	Output	Bool
340	E3 IC: Limit value exceeded	Output	Bool
410	E4 IC: Limit value exceeded	Output	Bool
513	E5 IC: Limit value exceeded	Output	Bool

If the parameterized limit value of the intermediate counter is exceeded, the excess is sent to the KNX bus as a 1-bit value.

10.2.70 E1-E5 – IC – Reverse direction

Number	Name	Object function	Data type (DPT)
181	E1 IC: Reverse direction	Input	Bool
272	E2 IC: Reverse direction	Input	Bool
342	E3 IC: Reverse direction	Input	Bool
412	E4 IC: Reverse direction	Input	Bool
515	E5 IC: Reverse direction	Input	Bool

The counting direction of the intermediate counter can be changed using this object.

10.2.71 E1-E5 – IC – Reset

Number	Name	Object function	Data type (DPT)
182	E1 IC: Reset	Input	Bool
273	E2 IC: Reset	Input	Bool
343	E3 IC: Reset	Input	Bool
413	E4 IC: Reset	Input	Bool
516	E5 IC: Reset	Input	Bool

The intermediate counter is reset to the value "0".

10.2.72 E1-E5 – IC – Counter reading 1-byte value

Number	Name	Object function	Data type (DPT)
172	E1 IC: Counter reading 1-byte value	Output	Value_1_Count
173			Value_1_Ucount
263	E2 IC: Counter reading 1-byte value	Output	Value_1_Count
264			Value_1_Ucount
333	E3 IC: Counter reading 1-byte value	Output	Value_1_Count
334			Value_1_Ucount
403	E4 IC: Counter reading 1-byte value	Output	Value_1_Count
404			Value_1_Ucount
506	E5 IC: Counter reading 1-byte value	Output	Value_1_Count
507			Value_1_Ucount

The output transfers the intermediate counter value to the KNX bus in the form of a 1-byte value.

10.2.73 E1-E5 – IC – Counter reading 2-byte value

Number	Name	Object function	Data type (DPT)
174	E1 IC: Counter reading 2-byte value	Output	Value_2_Count
175			Value_2_Ucount
264	E2 IC: Counter reading 2-byte value	Output	Value_2_Count
265			Value_2_Ucount
335	E3 IC: Counter reading 2-byte value	Output	Value_2_Count
336			Value_2_Ucount
405	E4 IC: Counter reading 2-byte value	Output	Value_2_Count
406			Value_2_Ucount
508	E5 IC: Counter reading 2-byte value	Output	Value_2_Count
509			Value_2_Ucount

The output transfers the intermediate counter value to the KNX bus in the form of a 2-byte value.

10.2.74 E1-E5 – IC – Counter reading 4-byte value

Number	Name	Object function	Data type (DPT)
176	E1 IC: Counter reading 4-byte value	Output	Value_4_Count
267	E2 IC: Counter reading 4-byte value	Output	Value_4_Count
337	E3 IC: Counter reading 4-byte value	Output	Value_4_Count
407	E4 IC: Counter reading 4-byte value	Output	Value_4_Count
510	E5 IC: Counter reading 4-byte value	Output	Value_4_Count

The output transfers the intermediate counter value to the KNX bus in the form of a 4-byte value.

10.2.75 E1-E5 – IC – Request counter reading

Number	Name	Object function	Data type (DPT)
180	E1 IC: Request counter reading	Input	Switch
271	E2 IC: Request counter reading	Input	Switch
341	E3 IC: Request counter reading	Input	Switch
411	E4 IC: Request counter reading	Input	Switch
514	E5 IC: Request counter reading	Input	Switch

The current reading of the intermediate counter can be read/requested via the KNX bus.

10.2.76 E4 – 2-byte threshold value 1

Number	Name	Object function	Data type (DPT)
427	E4: 2-byte threshold value 1	Output	Value_2_Ucount

The value sent via the object is parameterized in the application. This parameterized value is sent to the KNX bus after the threshold is exceeded.

10.2.77 E4 – 2-byte threshold value 2

Number	Name	Object function	Data type (DPT)
439	E4: 2-byte threshold value 2	Output	Value_2_Ucount

The value sent via the object is parameterized in the application. This parameterized value is sent to the KNX bus after the threshold is exceeded.

10.2.78 E4 – Output value

Number	Name	Object function	Data type (DPT)
417	E4: Output value	Output	Value_Temp
422			

The value measured via the external temperature sensor (6226/T or PT1000) is made available to the KNX as a 2-byte value.

10.2.79 E4 – Request output value

Number	Name	Object function	Data type (DPT)
418	E4: Request output value	Input	Switch
423			

This value can be retrieved via the communication object using the KNX bus.

10.2.80 E4 – Bit threshold value 1

Number	Name	Object function	Data type (DPT)
425	E4: Bit threshold value 1	Output	Switch

The value sent via the object is parameterized in the application. This parameterized value is sent to the KNX bus after the threshold is exceeded.

10.2.81 E4 – Bit threshold value 2

Number	Name	Object function	Data type (DPT)
437	E4: Bit threshold value 2	Output	Switch

The value sent via the object is parameterized in the application. This parameterized value is sent to the KNX bus after the threshold is exceeded.

10.2.82 E4 – Byte threshold value 1

Number	Name	Object function	Data type (DPT)
426	E4: Byte threshold value 1	Output	Value_1_Ucount

The value sent via the object is parameterized in the application. This parameterized value is sent to the KNX bus after the threshold is exceeded.

10.2.83 E4 – Byte threshold value 2

Number	Name	Object function	Data type (DPT)
438	E4: Byte threshold value 2	Output	Value_1_Ucount

The value sent via the object is parameterized in the application. This parameterized value is sent to the KNX bus after the threshold is exceeded.

10.2.84 E4 – Measured value outside of range

Number	Name	Object function	Data type (DPT)
419	E4: Measured value outside of range	Output	Switch
424			

The temperature sensor has a defined measuring range. If it is exceeded, this communication object outputs a 1-bit telegram with the value "1".

10.2.85 E4 – Change threshold, tolerance band upper limit

Number	Name	Object function	Data type (DPT)
430	E4: Change threshold, tolerance band upper limit	Input	Value_Temp

The upper temperature tolerance limit can be adjusted/changed using the KNX bus. The change is not visible in the ETS application. After downloading the application, it may be necessary to readjust the temperature.

10.2.86 E4 – Change threshold, tolerance band lower limit

Number	Name	Object function	Data type (DPT)
429	E4: Change threshold, tolerance band lower limit	Input	Value_Temp

The lower temperature tolerance limit can be adjusted/changed using the KNX bus. The change is not visible in the ETS application. After downloading the application, it may be necessary to readjust the temperature.

10.2.87 E4 – Change threshold, tolerance band 2 upper limit

Number	Name	Object function	Data type (DPT)
442	E4: Change threshold, tolerance band 2 upper limit	Input	Value_Temp

The upper temperature tolerance limit can be adjusted/changed using the KNX bus. The change is not visible in the ETS application. After downloading the application, it may be necessary to readjust the temperature.

10.2.88 E4 – Change temperature, tolerance band 2 lower limit

Number	Name	Object function	Data type (DPT)
441	E4: Change temperature, tolerance band 2 lower limit	Input	Scaling

The lower temperature tolerance limit can be adjusted/changed using the KNX bus. The change is not visible in the ETS application. After downloading the application, it may be necessary to readjust the temperature.

10.2.89 E4 – Send if threshold value 1 undershot

Number	Name	Object function	Data type (DPT)
431	E4: Send if threshold value 1 undershot	Input	Value_1_Ucount
433			Value_2_Ucount
443			Value_1_Ucount
445			Value_2_Ucount
447			Value_Temp

If the parameterized threshold value is undershot, the value that is undershot is sent to the KNX bus.

10.2.90 E4 – Send if threshold value 1 exceeded

Number	Name	Object function	Data type (DPT)
432	E4: Send if threshold value 1 exceeded	Input	Value_1_Ucount
434			Value_2_Ucount
436			Value_Temp
444			Value_1_Ucount
446			Value_2_Ucount
448			Value_Temp

If the parameterized threshold value is exceeded, the value that is exceeded is sent to the KNX bus.

10.2.91 E4 – Temperature threshold value 1

Number	Name	Object function	Data type (DPT)
428	E4: Temperature threshold value 1	Output	Value_Temp

If the temperature is exceeded, the parameterized value is sent to the KNX bus via the communication object.

10.2.92 E4 – Temperature threshold value 2

Number	Name	Object function	Data type (DPT)
440	E4: Temperature threshold value 2	Output	Value_Temp

If the temperature is exceeded, the parameterized value is sent to the KNX bus via the communication object.

10.2.93 E4 – Heating temperature limit

Number	Name	Object function	Data type (DPT)
420	E4: Heating temperature limit	Output	Switch

The object issues the adjustment command to the room temperature controller or the heating actuator when the parameterized temperature is reached.

The connected valve is approached for protection. The limit is not cancelled until the temperature is undershot.

10.2.94 P – Air pressure sensor error

Number	Name	Object function	Data type (DPT)
574	P: Air pressure sensor error	Output	Bool

If a sensor defect occurs or no current value is available to the KNX bus, a telegram with the value "1" is sent to the KNX bus.

A telegram with the value "0" resets the error.

10.2.95 P – Request relative air pressure

Number	Name	Object function	Data type (DPT)
576	P: Request relative air pressure	Input	Triggers

If the external value is not to be sent cyclically or if the device is being reset, the external value is requested via this object.

10.2.96 RFR – Basic set value (1 byte) [%]

Number	Name	Object function	Data type (DPT)
553	RFR: Basic set value (1 byte) [%]	Input	Scaling

Another basic set value can be specified for the device via the object.

Once a new value has been received, this acts as the new reference point and therefore has a direct impact on the measuring results of the device.

10.2.97 RFR – Basic set value [%]

Number	Name	Object function	Data type (DPT)
552	RFR: Basic set value [%]	Input	Value_Humidity

Another basic set value can be specified for the device via the object.

Once a new value has been received, this acts as the new reference point and therefore has a direct impact on the measuring results of the device.

10.2.98 RFR – Blocking object

Number	Name	Object function	Data type (DPT)
557	RFR: Blocking object	Input	Enable
558			

When the value "1" is received, all the KNX communication of the CO₂ sensor is blocked and is no longer part of KNX bus communication.

Unblocking happens when the value "0" is received.

10.2.99 RFR – Blocking object threshold 1

Number	Name	Object function	Data type (DPT)
554	RFR: Blocking object threshold 1	Input	Enable

When the value "1" is received, threshold 1 is blocked and is no longer part of KNX bus communication. Unblocking happens when the value "0" is received.

10.2.100 RFR – Blocking object threshold 2

Number	Name	Object function	Data type (DPT)
555	RFR: Blocking object threshold 2	Input	Enable

When the value "1" is received, threshold 2 is blocked and is no longer part of KNX bus communication. Unblocking happens when the value "0" is received.

10.2.101 RFR – Blocking object threshold 3

Number	Name	Object function	Data type (DPT)
556	RFR: Blocking object threshold 3	Input	Enable

When the value "1" is received, threshold 3 is blocked and is no longer part of KNX bus communication. Unblocking happens when the value "0" is received.

10.2.102 RFR – Control value (0 to 100%)

Number	Name	Object function	Data type (DPT)
544	RFR: Control value (0 to 100%)	Output	Scaling

If this output is parameterized, the relevant value is sent once the parameterized threshold is exceeded.

10.2.103 RFR – Control value (0 to 255)

Number	Name	Object function	Data type (DPT)
543	RFR: Control value (0 to 255)	Output	Value_1_Ucount

If this output is parameterized, the relevant value is sent once the parameterized threshold is exceeded.

10.2.104 RFR – Control value step 1 (priority)

Number	Name	Object function	Data type (DPT)
547	RFR: Control value step 1 (priority)	Output	Switch_Control

Each control value step can be parameterized using a defined 2-bit value. If the step in question is exceeded, the value is output via the object.

10.2.105 RFR – Control value step 1 (switch object)

Number	Name	Object function	Data type (DPT)
546	RFR: Control value step 1 (switch object)	Output	Switch

Each control value step can be parameterized using a defined 1-bit value. If the step in question is exceeded, the value is output via the object.

10.2.106 RFR – Control value step 2 (priority)

Number	Name	Object function	Data type (DPT)
549	RFR: Control value step 2 (priority)	Output	Switch_Control

Each control value step can be parameterized using a defined 2-bit value. If the step in question is exceeded, the value is output via the object.

10.2.107 RFR – Control value step 2 (switch object)

Number	Name	Object function	Data type (DPT)
548	RFR: Control value step 2 (switch object)	Output	Switch

Each control value step can be parameterized using a defined 1-bit value. If the step in question is exceeded, the value is output via the object.

10.2.108 RFR – Control value step 3 (priority)

Number	Name	Object function	Data type (DPT)
551	RFR: Control value step 3 (priority)	Output	Switch_Control

Each control value step can be parameterized using a defined 2-bit value. If the step in question is exceeded, the value is output via the object.

10.2.109 RFR – Control value step 3 (switch object)

Number	Name	Object function	Data type (DPT)
550	RFR: Control value step 3 (switch object)	Output	Switch

Each control value step can be parameterized using a defined 1-bit value. If the step in question is exceeded, the value is output via the object.

10.2.110 RFR – Scene (1 to 64)

Number	Name	Object function	Data type (DPT)
545	RFR: Scene (1 to 64)	Output	SceneNumber

If this output is parameterized, the relevant scene number is sent and, therefore, the required scene is started once the parameterized threshold is exceeded.

10.2.111 T – Frost alarm

Number	Name	Object function	Data type (DPT)
564	T: Frost alarm	Output	Bool

If the parameterized temperature is undershot, the value "1" is made available to the "Frost alarm" communication object. The alarm is cancelled with the value "0" when the temperature is exceeded.

10.2.112 T – Heat alarm

Number	Name	Object function	Data type (DPT)
563	T: Heat alarm	Output	Bool

If the parameterized temperature is exceeded, the value "1" is made available to the "Heat alarm" communication object. The alarm is cancelled with the value "0" when the temperature is undershot.

10.2.113 T – Sensor error

Number	Name	Object function	Data type (DPT)
562	T: Sensor error	Output	Bool

If a sensor defect occurs or no current value is available to the KNX bus, a telegram with the value "1" is sent to the bus.

A telegram with the value "0" resets the error.

10.2.114 T – Temperature value [°C]

Number	Name	Object function	Data type (DPT)
559	T: Temperature value [°C]	Output	Value_Temp

The temperature value measured by the device is available via the communication object.

10.2.115 T – Request temperature value

Number	Name	Object function	Data type (DPT)
561	T – Request temperature value	Input	Trigger

If the external value is not to be sent cyclically or if the device is being reset, the external value is requested via this object.

10.2.116 T – External temperature value [°C]

Number	Name	Object function	Data type (DPT)
560	T: External temperature value [°C]	Input	Value_Temp

If another temperature value is to be included in the measurement, this input can be linked with the other output of a corresponding device.

10.2.117 rH – Humidity value [%]

Number	Name	Object function	Data type (DPT)
538	rH: Humidity value [%]	Output	Value_Humidity

The relative humidity value measured by the device is available via the communication object.

10.2.118 rH – Request humidity value

Number	Name	Object function	Data type (DPT)
541	rH: Request humidity value	Input	Trigger

If the external value is not to be sent cyclically or if the device is being reset, the external value is requested via this object.

10.2.119 rH – External humidity value [%]

Number	Name	Object function	Data type (DPT)
540	rH: External humidity value [%]	Input	Value_Humidity

If another relative humidity value is to be included in the measurement, this input can be linked with the other output of a corresponding device.

10.2.120 rH – Sensor error

Number	Name	Object function	Data type (DPT)
542	rH: Sensor error	Output	Bool

If a sensor defect occurs or no current value is available to the KNX bus, a telegram with the value "1" is sent to the bus.

A telegram with the value "0" resets the error.

10.3 Application "RTC"

10.3.1 General - Device function

Options:	Single device
	Master device
	Slave device

- *Single device*: The device is used singly in a room as room temperature controller.
- *Master device*: At least two room temperature controllers are located in one room. One device is to be set up as a master device, while the others are to be programmed as slave devices / temperature sensors. The master device is to be linked to the slave devices using the appropriately labelled communication objects. The master device regulates the temperature.
- *Slave device/temperature sensor*: At least two room temperature controllers are located in one room. One device is to be set up as a master device, while the others are to be programmed as slave devices / temperature sensors. The slave devices are to be linked to the master device with the appropriately labelled communication objects. The slave device serves the room temperature control functions of the master.

10.3.2 General - Control function

Options:	Heating
	Heating with additional stage
	Cooling
	Cooling with additional stage
	Heating and cooling
	Heating and cooling with additional stage

- *Heating*: For operating a heat-based automatic single-room control. The temperature is regulated to the setpoint value defined in the parameter. The "Controller type" and "Heating type" can be programmed for optimal control.
- *Heating with additional stage*: In addition to the control function described under heating, the additional stage enables the activation of an additional heating circuit. This type of additional stage is used, for example, to quickly heat up a bathroom with floor heating via a heated towel rack.
- *Cooling*: For operating a cooling-based automatic single-room control. The temperature is regulated to the setpoint value defined in the parameter. The "Controller type" and "Cooling type" can be programmed for optimal control.
- *Cooling with additional stage*: In addition to the control function described under cooling, the additional stage enables the activation of an additional cooling device. This type of additional stage is used, for example, to quickly cool a room via an added cooling device.
- *Heating and cooling*: For operating a two-wire or four-wire system used to heat or cool a room. Switching between heating and cooling takes place using a central switch (two-wire system) or is carried out manually and / or automatically via the single room temperature controller (four-wire system).
- *Heating and cooling with an additional stage*: In addition to the heating and cooling functions, one additional stage each with an autonomous controller type can be programmed.

**Note**

This parameter is only available if the "Device function" parameter is set on "Single device" or "Master device".

10.3.3 General - Operating mode after reset

Options:	Comfort
	Standby
	Eco mode
	Cooling with additional stage
	Frost/heat protection

After a reset the device will run in the operating mode after a restart until a new operating mode is set as the result of device operation or by communication objects, as the case may be. This operating mode should be defined during the planning phase. An improperly defined operating mode can result in a loss of comfort or increased energy consumption.

- *Comfort*: If the room temperature is not automatically lowered and the room is therefore controlled independent of its use.
- *Standby*: If the room is controlled automatically, e.g. by a presence detector, as a function of its use.
- *Eco mode*: If the room is controlled automatically or manually as a function of its use.
- *Frost/heat protection*: If only the building protection function is necessary in the room after a reset.

**Note**

This parameter is only available if the "Device function" parameter is set on "Single device" or "Master device".

10.3.4 General - Additional functions

Options:	No
	Yes

- This parameter enables additional functions and communication objects, e.g. window contact and presence detector.

10.3.5 General - Send cyclic "In operation" (min)

Options:	Setting option between 5 - 3000 minutes
----------	---

- The "In operation" communication object serves to inform that the controller still operates. Value "1" is sent cyclic. This parameter is used to set the cycle for sending. If the cyclic telegram fails, the function of the device is faulty and the air-conditioning of the room can be maintained with a forced operation. However, for this the system and/or actuator must have "Forced operation" function.



Note

This parameter is only available if the "Additional function" parameter is set to "Yes".

10.3.6 Heating control



Note

Only available when the "Device function" parameter is set on either "Single device" or "Master device" and the control function parameter is set on either "Heating", "Heating with additional stage", "Heating and cooling" or "Heating and cooling with additional stages".

10.3.7 Heating control - Control value type

Options:	2-point 1 bit, Off/On
	2-point 1 byte, (0/100%)
	PI continuous, 0-100%
	PI PWM, On/Off
	Fan coil

The actuation of the control valve is determined by the selection of the controller type.

- *2-Point 1 Bit, Off/On*: The 2-point control is the simplest type of control. The controller switches on when the room temperature drops below a certain level (setpoint temperature value minus hysteresis) and switches off when a particular value (setpoint temperature value plus hysteresis) is exceeded. The switch-on and switch-off commands are transmitted as 1-bit commands.
- *2-Point 1 Byte, 0/100%*: This is another two-point control as described above. In this case, however, the switch-on and switch-off commands are transmitted as 1-byte values (0% / 100%).
- *PI continuous, 0-100%*: The PI controller adjusts its output value between 0% and 100% to match the difference between the actual value and the setpoint value and enables a precise regulation of the room temperature to the setpoint value. It sends the control value to the bus as a 1-byte value (0% - 100%). To reduce the bus load, the control value is only transmitted if it has changed by a predefined percentage in relation to the previous sent value. The control value can also be transmitted cyclically.
- *PI PWM, On/Off*: This also is a PI controller. Here, the output is a 1-bit command. For this to occur, the calculated control value is converted into a pulse-interval signal.
- *Fan coil*: The fan coil controller operates like the PI continuous controller. In addition, it allows the separate activation of the fan in the fan coil unit (e.g. fan speed levels 1 - 3).

10.3.8 Heating control - Heating type

Options:	PI continuous, 0 – 100% and PI PWM, On/Off: <ul style="list-style-type: none"> ▪ Area (e.g. floor heating) 4°C 200 min ▪ Convector (e.g. heater) 1.5°C 100 min ▪ Free configuration
	Fan coil: <ul style="list-style-type: none"> ▪ Fan coil 4°C 90 min ▪ Free configuration

Multiple heating types (panel heating, convector heating or fan coil) with preset parameters are available to the user.

- If the required heating type is not available, individual parameters can be specified in free configuration.



Note

This parameter is only available when "Control value type" parameter is set either on "PI continuous, 0 – 100%", "PI PWM, On/Off" or "Fan coil".

10.3.9 Heating control - P-component (x 0.1°C)

Options:	Setting option between 10 - 100
----------	---------------------------------

The P-component refers to the proportional band of a control. It fluctuates around the setpoint value and can be used to influence control speed with a PI controller. The smaller the setpoint, the faster it reacts to the control. However, to avoid the risk of an overshoot, this value should not be set too low. A P-component from 0.1 to 25.5 K can be set.



Note

This parameter is only available when "Control value type" parameter is set either on "PI continuous, 0 – 100%", "PI PWM, On/Off" or "Fan coil". In addition, the "Heating type" parameter must be set on "Free configuration".

10.3.10 Heating control - I-component (min.)

Options:	Setting option between 0 - 255
----------	--------------------------------

The I-component refers to the reset time of a control. The integral component has the effect of moving the room temperature slowly toward, and ultimately reaching, the setpoint value. Depending on the type of system used, the reset time has to have different values. In general, the more inactive the overall system, the greater the reset time.



Note

This parameter is only available when "Control value type" parameter is set either on "PI continuous, 0 – 100%", "PI PWM, On/Off" or "Fan coil". In addition, the "Heating type" parameter must be set on "Free configuration".

10.3.11 Heating control - Extended settings

Options:	No
	Yes

- This parameter enables additional functions and communication objects, e.g. "Basic stage heating".

10.3.12 Basic stage heating



Note

Only available when the "Extended settings" parameter under "Heating control" is set on "Yes".

10.3.13 Basic stage heating - Status object heating

Options:	No
	Yes

- This parameter enables the "Status heating" communication object.

10.3.14 Basic stage heating - Mode of the control value

Options:	Normal
	Inverse

The mode of the control value can be used to adapt the control value to de-energised opened (normal) or de-energised closed (inverse) valves.

- *Normal*: Value 0 means "Valve closed".
- *Inverse*: Value 0 means "Valve open".

10.3.15 Basic stage heating - Hysteresis (x 0.1°C)

Options:	Setting option between 3 - 255
----------	--------------------------------

The hysteresis of the two-point controller specifies the fluctuation range of the controller around the setpoint value. The lower switching point is located at "Setpoint value minus hysteresis" and the upper point is at "Setpoint value plus hysteresis".



Note

This parameter is only available when the "Control value type" parameter is set either on "2-point 1 Bit, Off/On" or "2-point 1 Byte, 0/100%".

10.3.16 Basic stage heating - Control value difference for sending of heating control value

Options:	2 %
	5 %
	10 %
	Send cyclic only

The control values of the 0 - 100% PI continuous controller are not transmitted after every calculation. Instead, they are transmitted when the calculation results in a value that is different enough to the previous sent value to make a transmission meaningful. This value difference can be entered here.

**Note**

This parameter is only available when "Control value type" parameter is set either on "PI continuous, 0 – 100%", "PI PWM, On/Off" or "Fan coil".

10.3.17 Basic stage heating - Cyclic sending of the control value (min)

Options:	Setting option between 1 - 60 minutes
----------	---------------------------------------

The current control value used by the device can be cyclically transmitted to the bus.

**Note**

This parameter is only available when the "Control value type" parameter is set either on "2-point 1 Bit, Off/On", "2-point 1 Byte, 0/100%", "PI continuous, 0-100%" or "Fan coil".

10.3.18 Basic stage heating - PWM cycle heating (min)

Options:	Setting option between 1 - 60 minutes
----------	---------------------------------------

In PI PWM, On/off the control value percentage values are converted into a pulse-interval signal. This means that a selected PWM cycle will be divided into an on-phase and an off-phase based on the control value. Accordingly, a control value output of 33% in a PWM cycle of 15 min. results in an "On-phase" of five minutes and an "Off-phase" of 10 min. The time for a PWM cycle can be specified here.

**Note**

This parameter is only available when the "Control value type" parameter is set on "PI PWM, On/Off".

10.3.19 Basic stage heating - Maximum control value (0 - 255)

Options:

Setting option between 0 - 255

The maximum control value of the PI controller defines the maximum value outputted by the controller. If a maximum value under 255 is chosen, the value will not be exceeded, even if the controller calculates a higher control value.



Note

This parameter is only available when "Control value type" parameter is set either on "PI continuous, 0 – 100%", "PI PWM, On/Off" or "Fan coil".

10.3.20 Basic stage heating - Minimum control value for basic load (0 to 255)

Options:

Setting option between 0 - 255

The minimum control value of the PI controller defines the minimum value output by the controller. If a minimum value greater than zero is chosen, the controller will not output a lower value, even if it calculates a value that is lower. This parameter can be used to set a basic load, e.g. for operating floor heating. Even if the controller calculates the control value zero, a heating medium will flow through the floor heating system to prevent the floor from cooling down. Under "Settings of basic load", it is also possible to define whether this basic load will be permanently active or whether it will be switched by the "Basic load" object.



Note

This parameter is only available when "Control value type" parameter is set either on "PI continuous, 0 – 100%", "PI PWM, On/Off" or "Fan coil".

10.3.21 Control of additional heating stage



Note

Only available when the "Device function" parameter is set on either "Single device" or "Master device" and the control function parameter is set on either "Heating with additional stage" or "Heating and cooling with additional stages".

10.3.22 Control of additional heating stage - Control value type

Options:	2-point 1 bit, Off/On
	2-point 1 byte, (0/100%)
	PI continuous, 0-100%
	PI PWM, On/Off
	Fan coil

The actuation of the control valve is determined by the selection of the controller type.

- *2-Point 1 Bit, Off/On*: The 2-point control is the simplest type of control. The controller switches on when the room temperature drops below a certain level (setpoint temperature value minus hysteresis) and switches off when a particular value (setpoint temperature value plus hysteresis) is exceeded. The switch-on and switch-off commands are transmitted as 1-bit commands.
- *2-Point 1 Byte, 0/100%*: This is another two-point control as described above. In this case, however, the switch-on and switch-off commands are transmitted as 1-byte values (0% / 100%).
- *PI continuous, 0-100%*: The PI controller adjusts its output value between 0% and 100% to match the difference between the actual value and the setpoint value and enables a precise regulation of the room temperature to the setpoint value. It sends the control value to the bus as a 1-byte value (0% - 100%). To reduce the bus load, the control value is only transmitted if it has changed by a predefined percentage in relation to the previous sent value. The control value can also be transmitted cyclically.
- *PI PWM, On/Off*: This also is a PI controller. Here, the output is a 1-bit command. For this to occur, the calculated control value is converted into a pulse-interval signal.
- *Fan coil*: The fan coil controller operates like the PI continuous controller. In addition, it allows the separate activation of the fan in the fan coil unit (e.g. fan speed levels 1 - 3).

10.3.23 Control of additional heating stage - Additional heating type

Options:	PI continuous, 0 – 100% and PI PWM, On/Off: <ul style="list-style-type: none"> ▪ Area (e.g. floor heating) 4°C 200 min ▪ Convector (e.g. heater) 1.5°C 100 min ▪ Free configuration
	Fan coil: <ul style="list-style-type: none"> ▪ Fan coil 4°C 90 min ▪ Free configuration

Multiple heating types (panel heating, convector heating or fan coil) with preset parameters are available to the user.

- If the required heating type is not available, individual parameters can be specified in free configuration.



Note

This parameter is only available when "Control value type" parameter is set either on "PI continuous, 0 – 100%", "PI PWM, On/Off" or "Fan coil".

10.3.24 Control of additional heating stage - P-component (x 0.1°C)

Options:	Setting option between 10 - 100
----------	---------------------------------

The P-component refers to the proportional band of a control. It fluctuates around the setpoint value and can be used to influence control speed with a PI controller. The smaller the setpoint, the faster it reacts to the control. However, to avoid the risk of an overshoot, this value should not be set too low. A P-component from 0.1 to 25.5 K can be set.

**Note**

This parameter is only available when "Control value type" parameter is set either on "PI continuous, 0 – 100%", "PI PWM, On/Off" or "Fan coil". In addition, the "Additional heating type" parameter must be set on "Free configuration".

10.3.25 Control of additional heating stage - P-component (min)

Options:	Setting option between 0 - 255
----------	--------------------------------

The I-component refers to the reset time of a control. The integral component has the effect of moving the room temperature slowly toward, and ultimately reaching, the setpoint value. Depending on the type of system used, the reset time has to have different values. In general, the more inactive the overall system, the greater the reset time.

**Note**

This parameter is only available when "Control value type" parameter is set either on "PI continuous, 0 – 100%", "PI PWM, On/Off" or "Fan coil". In addition, the "Additional heating type" parameter must be set on "Free configuration".

10.3.26 Control of additional heating stage - Temperature difference to basic stage (x 0.1°C)

Options:	Setting option between 0 - 255
----------	--------------------------------

The setpoint temperature of the additional stage is defined as a function of the current setpoint temperature of the base stage and is expressed as a difference. The value represents the setpoint value starting at which the additional stage will operate.

10.3.27 Control of additional heating stage - Extended settings

Options:	No
	Yes

This parameter enables additional functions and communication objects, e.g. "Additional heating stage".

10.3.28 Additional heating stage**Note**

Only available when the "Extended settings" parameter under "Control of additional heating stage" is set on "Yes".

10.3.29 Additional heating stage - Mode of the control value

Options:	Normal
	Inverse

The mode of the control value can be used to adapt the control value to de-energised opened (normal) or de-energised closed (inverse) valves.

- *Normal*: Value 0 means "Valve closed".
- *Inverse*: Value 0 means "Valve open".

10.3.30 Additional heating stage - Hysteresis (x 0.1°C)

Options:	Setting option between 3 - 255
----------	--------------------------------

The hysteresis of the two-point controller specifies the fluctuation range of the controller around the setpoint value. The lower switching point is located at "Setpoint value minus hysteresis" and the upper point is at "Setpoint value plus hysteresis".

**Note**

This parameter is only available when the "Control value type" parameter is set either on "2-point 1 Bit, Off/On" or "2-point 1 Byte, 0/100%".

10.3.31 Additional heating stage - Control value difference for sending of heating control value

Options:	2 %
	5 %
	10 %
	Send cyclic only

The control values of the 0 - 100% PI continuous controller are not transmitted after every calculation. Instead, they are transmitted when the calculation results in a value that is different enough to the previous sent value to make a transmission meaningful. This value difference can be entered here.

**Note**

This parameter is only available when "Control value type" parameter is set either on "PI continuous, 0 – 100%", "PI PWM, On/Off" or "Fan coil".

10.3.32 Additional heating stage - Cyclic sending of the control value (min)

Options:	Setting option between 1 - 60 minutes
----------	---------------------------------------

The current control value used by the device can be cyclically transmitted to the bus.

**Note**

This parameter is only available when the "Control value type" parameter is set either on "2-point 1 Bit, Off/On", "2-point 1 Byte, 0/100%", "PI continuous, 0-100%" or "Fan coil".

10.3.33 Additional heating stage - Maximum control value (0 - 255)

Options:

Setting option between 0 - 255

The maximum control value of the PI controller defines the maximum value outputted by the controller. If a maximum value under 255 is chosen, the value will not be exceeded, even if the controller calculates a higher control value.

**Note**

This parameter is only available when "Control value type" parameter is set either on "PI continuous, 0 – 100%", "PI PWM, On/Off" or "Fan coil".

Additional heating stage - Minimum control value for basic load (0 - 255)

Options:

Setting option between 0 - 255

The minimum control value of the PI controller defines the minimum value output by the controller. If a minimum value greater than zero is chosen, the controller will not output a lower value, even if it calculates a value that is lower. This parameter can be used to set a basic load, e.g. for operating floor heating. Even if the controller calculates the control value zero, a heating medium will flow through the floor heating system to prevent the floor from cooling down. Under "Settings of basic load", it is also possible to define whether this basic load will be permanently active or whether it will be switched by the "Basic load" object.

**Note**

This parameter is only available when "Control value type" parameter is set either on "PI continuous, 0 – 100%", "PI PWM, On/Off" or "Fan coil".

10.3.34 Cooling control**Note**

Only available when the "Device function" parameter is set on either "Single device" or "Master device" and the control function parameter is set on either "Cooling", "Cooling with additional stage", "Heating and cooling" or "Heating and cooling with additional stages".

10.3.35 Cooling control - Control value type

Options:

2-point 1 bit, Off/On

2-point 1 byte, (0/100%)

PI continuous, 0-100%

PI PWM, On/Off

Fan coil

The actuation of the control valve is determined by the selection of the controller type.

- *2-Point 1 Bit, Off/On*: The 2-point control is the simplest type of control. The controller switches on when the room temperature drops below a certain level (setpoint temperature value minus hysteresis) and switches off when a particular value (setpoint temperature

- value plus hysteresis) is exceeded. The switch-on and switch-off commands are transmitted as 1-bit commands.
- *2-Point 1 Byte, 0/100%*: This is another two-point control as described above. In this case, however, the switch-on and switch-off commands are transmitted as 1-byte values (0% / 100%).
 - *PI continuous, 0-100%*: The PI controller adjusts its output value between 0% and 100% to match the difference between the actual value and the setpoint value and enables a precise regulation of the room temperature to the setpoint value. It sends the control value to the bus as a 1-byte value (0% - 100%). To reduce the bus load, the control value is only transmitted if it has changed by a predefined percentage in relation to the previous sent value. The control value can also be transmitted cyclically.
 - *PI PWM, On/Off*: This also is a PI controller. Here, the output is a 1-bit command. For this to occur, the calculated control value is converted into a pulse-interval signal.
 - *Fan coil*: The fan coil controller operates like the PI continuous controller. In addition, it allows the separate activation of the fan in the fan coil unit (e.g. fan speed levels 1 - 3).

10.3.36 Cooling control - Cooling type

Options:	PI continuous, 0 – 100% and PI PWM, On/Off:
	<ul style="list-style-type: none"> ▪ Area (e.g. cooling ceiling) 5°C 240 min ▪ Free configuration
	Fan coil:
	<ul style="list-style-type: none"> ▪ Fan coil 4°C 90 min ▪ Free configuration

Two cooling types (area or fan coil) with preset parameters are available to the user.

If the required cooling type is not available, individual parameters can be specified in free configuration.



Note

This parameter is only available when "Control value type" parameter is set either on "PI continuous, 0 – 100%", "PI PWM, On/Off" or "Fan coil".

10.3.37 Cooling control - P-component (x 0.1°C)

Options:	Setting option between 10 - 100
----------	---------------------------------

The P-component refers to the proportional band of a control. It fluctuates around the setpoint value and can be used to influence control speed with a PI controller. The smaller the setpoint, the faster it reacts to the control. However, to avoid the risk of an overshoot, this value should not be set too low. A P-component from 0.1 to 25.5 K can be set.



Note

This parameter is only available when "Control value type" parameter is set either on "PI continuous, 0 – 100%", "PI PWM, On/Off" or "Fan coil". In addition, the "Cooling type" parameter must be set on "Free configuration".

10.3.38 Cooling control - I-component (min.)

Options:	Setting option between 0 - 255
----------	--------------------------------

The I-component refers to the reset time of a control. The integral component has the effect of moving the room temperature slowly toward, and ultimately reaching, the setpoint value. Depending on the type of system used, the reset time has to have different values. In general, the more inactive the overall system, the greater the reset time.

**Note**

This parameter is only available when "Control value type" parameter is set either on "PI continuous, 0 – 100%", "PI PWM, On/Off" or "Fan coil". In addition, the "Cooling type" parameter must be set on "Free configuration".

10.3.39 Cooling control - Extended settings

Options:	No
	Yes

This parameter enables additional functions and communication objects, e.g. "Basic stage cooling".

10.3.40 Basic stage cooling**Note**

Only available when the "Extended settings" parameter under "Cooling control" is set on "Yes".

10.3.41 Basic stage cooling - Status object cooling

Options:	No
	Yes

This parameter enables the "Status cooling" communication object.

10.3.42 Basic stage cooling - Mode of the control value

Options:	Normal
	Inverse

The mode of the control value can be used to adapt the control value to de-energised opened (normal) or de-energised closed (inverse) valves.

- *Normal*: Value 0 means "Valve closed".
- *Inverse*: Value 0 means "Valve open".

10.3.43 Basic stage cooling - Hysteresis (x 0.1°C)

Options:	Setting option between 3 - 255
----------	--------------------------------

The hysteresis of the two-point controller specifies the fluctuation range of the controller around the setpoint value. The lower switching point is located at "Setpoint value minus hysteresis" and the upper point is at "Setpoint value plus hysteresis".



Note

This parameter is only available when the "Control value type" parameter is set either on "2-point 1 Bit, Off/On" or "2-point 1 Byte, 0/100%".

Basic stage cooling - Control value difference for sending of cooling control value

Options:	2 %
	5 %
	10 %
	Send cyclic only

The control values of the 0 - 100% PI continuous controller are not transmitted after every calculation. Instead, they are transmitted when the calculation results in a value that is different enough to the previous sent value to make a transmission meaningful. This value difference can be entered here.



Note

This parameter is only available when "Control value type" parameter is set either on "PI continuous, 0 – 100%", "PI PWM, On/Off" or "Fan coil".

10.3.44 Basic stage cooling - Cyclic sending of the control value (min)

Options:	Setting option between 1 - 60 minutes
----------	---------------------------------------

The current control value used by the device can be cyclically transmitted to the bus.



NOTE

This parameter is only available when the "Control value type" parameter is set either on "2-point 1 Byte, Off/On", "2-point 1 Byte, 0/100%", "PI continuous, 0-100%" or "Fan coil".

10.3.45 Basic stage cooling



Note

Only available when the "Extended settings" parameter under "Cooling control" is set on "Yes".

10.3.46 Basic stage cooling - Maximum control value (0 - 255)

Options:

Setting option between 0 - 255

The maximum control value of the PI controller defines the maximum value outputted by the controller. If a maximum value under 255 is chosen, the value will not be exceeded, even if the controller calculates a higher control value.

**Note**

This parameter is only available when "Control value type" parameter is set either on "PI continuous, 0 – 100%", "PI PWM, On/Off" or "Fan coil".

10.3.47 Basic stage cooling - Minimum control value for basic load (0 to 255)

Options:

Setting option between 0 - 255

The minimum control value of the PI controller defines the minimum value output by the controller. If a minimum value greater than zero is chosen, the controller will not output a lower value, even if it calculates a value that is lower. This parameter can be used to set a basic load, e.g. for operating surface cooling. Even if the controller calculates the control value zero, a cooling medium will flow through the cooling area to prevent the floor from heating up. Under "Settings of basic load", it is also possible to define whether this basic load will be permanently active or whether it will be switched by the "Basic load" object.

**Note**

This parameter is only available when "Control value type" parameter is set either on "PI continuous, 0 – 100%", "PI PWM, On/Off" or "Fan coil".

10.3.48 Control of additional cooling stage**Note**

Only available when the "Device function" parameter is set on either "Single device" or "Master device" and the control function parameter is set on either "Cooling with additional stage" or "Heating and cooling with additional stages".

Options:

2-point 1 bit, Off/On

2-point 1 byte, (0/100%)

PI continuous, 0-100%

PI PWM, On/Off

Fan coil

The actuation of the control valve is determined by the selection of the controller type.

- *2-Point 1 Bit, Off/On*: The 2-point control is the simplest type of control. The controller switches on when the room temperature drops below a certain level (setpoint temperature value minus hysteresis) and switches off when a particular value (setpoint temperature value plus hysteresis) is exceeded. The switch-on and switch-off commands are transmitted as 1-bit commands.

- *2-Point 1 Byte, 0/100%*: This is another two-point control as described above. In this case, however, the switch-on and switch-off commands are transmitted as 1-byte values (0% / 100%).
- *PI continuous, 0-100%*: The PI controller adjusts its output value between 0% and 100% to match the difference between the actual value and the setpoint value and enables a precise regulation of the room temperature to the setpoint value. It sends the control value to the bus as a 1-byte value (0% - 100%). To reduce the bus load, the control value is only transmitted if it has changed by a predefined percentage in relation to the previous sent value. The control value can also be transmitted cyclically.
- *PI PWM, On/Off*: This also is a PI controller. Here, the output is a 1-bit command. For this to occur, the calculated control value is converted into a pulse-interval signal.
- *Fan coil*: The fan coil controller operates like the PI continuous controller. In addition, it allows the separate activation of the fan in the fan coil unit (e.g. fan speed levels 1 - 3).

10.3.49 Control of additional cooling stage - Cooling type

Options:	PI continuous, 0 – 100% and PI PWM, On/Off: <ul style="list-style-type: none"> ▪ Area (e.g. cooling ceiling) 5°C 240 min ▪ Free configuration
	Fan coil: <ul style="list-style-type: none"> ▪ Fan coil 4°C 90 min ▪ Free configuration

Two cooling types (area or fan coil) with preset parameters are available to the user.

If the required cooling type is not available, individual parameters can be specified in free configuration.



Note

This parameter is only available when "Control value type" parameter is set either on "PI continuous, 0 – 100%", "PI PWM, On/Off" or "Fan coil".

10.3.50 Control of additional cooling stage - P-component (x 0.1°C)

Options:	Setting option between 10 - 100
----------	---------------------------------

The P-component refers to the proportional band of a control. It fluctuates around the setpoint value and can be used to influence control speed with a PI controller. The smaller the setpoint, the faster it reacts to the control. However, to avoid the risk of an overshoot, this value should not be set too low. A P-component from 0.1 to 25.5 K can be set.



Note

This parameter is only available when "Control value type" parameter is set either on "PI continuous, 0 – 100%", "PI PWM, On/Off" or "Fan coil". In addition, the "Cooling type" parameter must be set on "Free configuration".

10.3.51 Control of additional cooling stage - P-component (min)

Options:	Setting option between 0 - 255
----------	--------------------------------

The I-component refers to the reset time of a control. The integral component has the effect of moving the room temperature slowly toward, and to ultimately reaching, the setpoint. Depending on the type of system used, the reset time has to have different values. In general, the more inactive the overall system, the greater the reset time.

**Note**

This parameter is only available when "Control value type" parameter is set either on "PI continuous, 0 – 100%", "PI PWM, On/Off" or "Fan coil". In addition, the "Cooling type" parameter must be set on "Free configuration".

10.3.52 Control of additional cooling stage - Extended settings

Options:	No
	Yes

This parameter enables additional functions and communication objects, e.g. "Additional cooling stage".

10.3.53 Additional cooling stage

**Note**

Only available when the "Extended settings" parameter under "Control of additional cooling stage" is set on "Yes".

10.3.54 Additional cooling stage - Mode of the control value

Options:	Normal
	Inverse

The mode of the control value can be used to adapt the control value to de-energised opened (normal) or de-energised closed (inverse) valves.

- *Normal*: Value 0 means "Valve closed".
- *Inverse*: Value 0 means "Valve open".

10.3.55 Additional cooling stage - Hysteresis (x 0.1°C)

Options:	Setting option between 3 - 255
----------	--------------------------------

The hysteresis of the two-point controller specifies the fluctuation range of the controller around the setpoint value. The lower switching point is located at "Setpoint value minus hysteresis" and the upper point is at "Setpoint value plus hysteresis".

**Note**

This parameter is only available when the "Control value type" parameter is set either on "2-point 1 Bit, Off/On" or "2-point 1 Byte, 0/100%".

10.3.56 Additional cooling stage - Control value difference for sending of cooling control value

Options:	2%
	5%
	10%

The control values of the 0 - 100% PI continuous controller are not transmitted after every calculation. Instead, they are transmitted when the calculation results in a value that is different enough to the previous sent value to make a transmission meaningful. This value difference can be entered here.

**Note**

This parameter is only available when "Control value type" parameter is set either on "PI continuous, 0 – 100%", "PI PWM, On/Off" or "Fan coil".

10.3.57 Additional cooling stage - Cyclic sending of the control value (min)

Options:	Setting option between 1 - 60 minutes
----------	---------------------------------------

The current control value used by the device can be cyclically transmitted to the bus.

**Note**

This parameter is only available when the "Control value type" parameter is set either on "2-point 1 Bit, Off/On", "2-point 1 Byte, 0/100%", "PI continuous, 0-100%" or "Fan coil".

10.3.58 Additional cooling stage - Maximum control value (0 - 255)

Options:	Setting option between 0 - 255
----------	--------------------------------

The maximum control value of the PI controller defines the maximum value outputted by the controller. If a maximum value under 255 is chosen, the value will not be exceeded, even if the controller calculates a higher control value.

**Note**

This parameter is only available when "Control value type" parameter is set either on "PI continuous, 0 – 100%", "PI PWM, On/Off" or "Fan coil".

10.3.59 Additional cooling stage - Minimum control value for basic load (0 - 255)

Options:	Setting option between 0 - 255
----------	--------------------------------

The minimum control value of the PI controller defines the minimum value output by the controller. If a minimum value greater than zero is chosen, the controller will not output a lower value, even if it calculates a value that is lower. This parameter can be used to set a basic load, e.g. for operating surface cooling. Even if the controller calculates the control value zero, a cooling medium will flow through the cooling area to prevent the floor from heating up. Under "Settings of basic load", it is also possible to define whether this basic load will be permanently active or whether it will be switched by the "Basic load" object.



Note

This parameter is only available when "Control value type" parameter is set either on "PI continuous, 0 – 100%", "PI PWM, On/Off" or "Fan coil".

10.3.60 Settings of basic load



Note

Only available when the "Device function" parameter is set on either "Single device" or "Master device" and the control function parameter is set on either "Heating with additional stage", "Cooling with additional stage", "Heating and cooling" or "Heating and cooling with additional stages".

10.3.61 Settings of basic load - Minimum control value for basic load > 0

Options:	Always active
	Activate via object

The function finds application when in the desired area, e.g. with floor heating, the floor is to have a basic warmth. The size of the minimum control value specifies the volume of heating medium that flows through the controlled area, even when the calculation of the control value of the controller would indicate a lower value.

- *Always active*: Here it is possible to define whether this basic load will be permanently active or whether it will be switched via the "Basic load" object.
- *Activate via object*: When this parameter is selected, the basic load function, which means the minimum control value with a value higher than zero, can be activated (1) or deactivated (2). If it is activated, then the heating medium will always be fed through the system with at least the minimum control value. If it is deactivated, the control value can be reduced to zero with the controller.

10.3.62 Combined heating and cooling modes



Note

Only available when the "Device function" parameter is set on either "Single device" or "Master device" and the control function parameter is set on either "Heating and cooling" or "Heating and cooling with additional stages".

10.3.63 Combined heating and cooling modes - Switchover of heating/cooling

Options:	Automatic
	Only via object
	On-site/via extension unit and via object

This function makes it possible to switch between the heating and cooling mode of the device.

- *Automatic*: E.g. for four-conductor systems which allow the switchover between heating and cooling at all times. The device switches automatically between heating and cooling and to the associated setpoint. "Switchover heating/cooling" is a transmitting object.
- *Only via object*: E.g. for two-conductor systems which are operated in heating mode in the winter and cooling mode in the summer. The switchover between heating and cooling and to the associated setpoint is carried out via the corresponding communication object. This function is used when a central switchover of the single room controllers is required. "Switchover heating/cooling" is a receiving object.
- *Local/ via extension unit and via object*: E.g. for four-conductor systems which allow the switchover between heating and cooling at all times. The switchover between heating and cooling and to the associated setpoint is carried out manually on the device by the user of the room or via the "Switchover heating/cooling" object via the bus. "Switchover heating/cooling" is a transmitting and receiving object.

10.3.64 Combined heating and cooling modes - Operating mode after reset

Options:	Cooling
	Heating

After a bus voltage failure, a system reset, or the attachment of a device to the bus coupler, the device starts in the parameterized "Operating mode after reset". The operating mode can be changed when the system is running using the options set under "Switchover heating/cooling".

10.3.65 Combined heating and cooling modes - Heating/cooling control value output

Options:	Via 1 object
	Via 2 objects

This parameter is used to define whether the control value is transmitted to the climate control actuator using one or two objects. If the climate control actuator has separate control value inputs for heating and cooling, or if separate actuators are used, then the option "Via 2 objects" must be selected. Select the option "Via 1 object" if a single actuator only has one object that receives both the heating and the cooling control values.

10.3.66 Combined heating and cooling modes - Additional heating/cooling stage control value output

Options:	Via 1 object
	Via 2 objects

This parameter is used to define whether the control value is transmitted to the climate control actuator using one or two objects. If the climate control actuator has separate control value inputs for heating and cooling, or if separate actuators are used, then the option "Via 2 objects" must be selected. Select the option "Via 1 object" if a single actuator only has one object that receives both the heating and the cooling control values.



Note

This parameter is only available when the "Control function" parameter is set on "Heating and cooling with additional stages".

10.3.67 Setpoint settings



Note

This parameter is only available if the "Device function" parameter is set on either "Single device" or "Master device".

10.3.68 Setpoint settings - Setpoint for heating comfort = setpoint for cooling comfort

Options:	No
	Yes

This parameter is used to configure the manner in which the setpoint adjustment functions.

- **Yes:** The device has the same setpoint for heating and cooling in the comfort mode. The system switches to heating when the temperature drops below the setpoint minus hysteresis. It switches to cooling when the temperature exceeds the setpoint plus hysteresis. The hysteresis is parameterizable.
- **No:** The function has two separate setpoints for heating and cooling in the comfort mode. The device will display the currently active setpoint value. Switching between heating and cooling occurs via the "Switchover heating/cooling" parameter setting.



Note

This parameter is only available when the "Control function" parameter is set on "Heating and cooling" or "heating and cooling with additional stages".

10.3.69 Setpoint settings - Hysteresis for switchover heating/cooling (x 0.1°C)

Options:

Setting option between 5 - 100

This parameter specifies the one-sided hysteresis for switching between heating and cooling when "Setpoint heating comfort = Setpoint cooling comfort" is active. If the room temperature exceeds the setpoint temperature value plus hysteresis, the system switches to cooling. If the room temperature falls below the setpoint temperature value minus hysteresis, the system switches to heating.



Note

This parameter is only available when the "Setpoint heating comfort = Setpoint cooling comfort" parameter is set on "Yes".

10.3.70 Setpoint settings - Setpoint temperature for heating and cooling comfort (°C)

Options:

Setting option between 10 - 40

Specifies the comfort temperature for heating and cooling when people are present.



Note

This parameter is only available when the "Control function" parameter is set on "Heating and cooling" or "heating and cooling with additional stages".

10.3.71 Setpoint settings - Setpoint temperature for heating comfort (°C)

Options:

Setting option between 10 - 40

Specifies the comfort temperature for heating when people are present.



Note

This parameter is only available when the "Control function" parameter is set on "Heating" or "Heating with additional stage".

10.3.72 Setpoint settings - Reduction for standby heating (°C)

Options:

Setting option between 10 - 40

Specifies the temperature in heating mode when nobody is present. On devices with a display, this mode is indicated by the standby icon.



Note

This parameter is only available when the "Control function" parameter is set on "Heating", "Heating with additional stage", "Heating and cooling" or "Heating and cooling with additional stages".

10.3.73 Setpoint settings - Reduction for ECO heating (°C)

Options: Setting option between 0 - 15

Specifies the temperature in heating mode when nobody is present. On devices with a display, this mode is indicated by the eco icon.

10.3.74 Setpoint settings - Set-point temperature for frost protection (°C)

Options: Setting option between 5 - 15

Function for protecting the building against the cold. On devices with a display, this mode is indicated by the frost protection icon. Manual operation is blocked.



Note

This parameter is only available when the "Control function" parameter is set on "Heating", "Heating with additional stage", "Heating and cooling" or "Heating and cooling with additional stages".

10.3.75 Setpoint settings - Setpoint temperature for cooling comfort (°C)

Options: Setting option between 10 - 40

Specifies the comfort temperature for cooling when people are present.



Note

This parameter is only available when the "Control function" parameter is set on "Cooling" or "Cooling with additional stage".

10.3.76 Setpoint settings - Increase for standby cooling (°C)

Options: Setting option between 0 - 15

Specifies the temperature in cooling mode when nobody is present. On devices with a display, this mode is indicated by the standby icon.



Note

This parameter is only available when the "Control function" parameter is set on "Cooling", "Cooling with additional stage", "Heating and cooling" or "Heating and cooling with additional stages".

10.3.77 Setpoint settings - Increase for ECO cooling (°C)

Options: Setting option between 0 - 15

Specifies the temperature in cooling mode when nobody is present. On devices with a display, this mode is indicated by the eco icon.



Note

This parameter is only available when the "Control function" parameter is set on "Cooling", "Cooling with additional stage", "Heating and cooling" or "Heating and cooling with additional stages".

10.3.78 Setpoint settings - Set-point temperature for heat protection (°C)

Options:	Setting option between 27 - 45
----------	--------------------------------

Function for protecting the building against heat. On devices with a display, this mode is indicated by the heat protection icon. Manual operation is blocked.

**Note**

This parameter is only available when the "Control function" parameter is set on "Cooling", "Cooling with additional stage", "Heating and cooling" or "Heating and cooling with additional stages".

10.3.79 Setpoint settings - Display indicates

Options:	Current setpoint
	Relative setpoint

The display can indicate either the absolute or relative setpoint value.

- *Current setpoint*: On devices with a display, the setpoint is shown as an absolute temperature, e.g. 21.0°C.
- *Relative setpoint*: On devices with display, the setpoint is indicated as a relative value, e.g. - 5°C .. + 5°C.

10.3.80 Setpoint settings - Display indicates

Options:	Current setpoint
	Relative setpoint

The display can indicate either the absolute or relative setpoint value.

- *Current setpoint*: On devices with a display, the setpoint is shown as an absolute temperature, e.g. 21.0°C.
- *Relative setpoint*: On devices with display, the setpoint is indicated as a relative value, e.g. - 5°C .. + 5°C.

10.3.81 Setpoint settings - Send current setpoint

Options:	Cyclic and during change
	Only for change

The current setpoint value can be sent to the bus either cyclically and after a change, or only after a change.

10.3.82 Setpoint settings - Cyclic sending of the current set-point temperature (min)

Options:

Setting option between 5 - 240

This parameter is used to specify the amount of time that will elapse before the current setpoint value is automatically transmitted.

**Note**

This parameter is only available when the "Send current setpoint" is set on "Only during change".

10.3.83 Setpoint adjustment**Note**

This parameter is only available if the "Device function" parameter is set on either "Single device" or "Master device".

10.3.84 Setpoint adjustment — Maximum manual increase during heating mode (0 - 15°C)

Options:

Setting option between 0 - 15

This preset can be used to limit the manual increase during heating.

**Note**

This parameter is only available when the "Control function" parameter is set on "Heating", "Heating with additional stage", "Heating and cooling" or "Heating and cooling with additional stages".

10.3.85 Setpoint adjustment — Maximum manual reduction during heating mode (0 - 15°C)

Options:

Setting option between 0 - 15

This preset can be used to limit the manual decrease during heating.

**Note**

This parameter is only available when the "Control function" parameter is set on "Heating", "Heating with additional stage", "Heating and cooling" or "Heating and cooling with additional stages".

10.3.86 Setpoint adjustment — Maximum manual increase during cooling mode (0 - 15°C)

Options:

Setting option between 0 - 15

This preset can be used to limit the manual increase during cooling.

**Note**

This parameter is only available when the "Control function" parameter is set on "Cooling", "Cooling with additional stage", "Heating and cooling" or "Heating and cooling with additional stages".

10.3.87 Setpoint adjustment — Maximum manual reduction during cooling mode (0 - 15°C)

Options:	Setting option between 0 - 15
----------	-------------------------------

This preset can be used to limit the manual decrease during cooling.

**Note**

This parameter is only available when the "Control function" parameter is set on "Cooling", "Cooling with additional stage", "Heating and cooling" or "Heating and cooling with additional stages".

10.3.88 Setpoint adjustment - Resetting of the manual adjustment for receipt of a basic setpoint

Options:	No
	Yes

Activating this parameter will cause the manual adjustment to be deleted and the new setpoint value to be provided when a new value is received via the "Basic setpoint" object.

If the parameter is deactivated, the manual adjustment is added to the new base setpoint value. Example: Previous base setpoint value of 21°C + manual adjustment of 1.5°C = 22.5°C. The object receives a new basic setpoint of 18°C plus the previous manual adjustment of 1.5°C for a total of 19.5°C.

10.3.89 Setpoint adjustment - Resetting the manual adjustment for change of operating mode

Options:	No
	Yes

If the device switches to a new operating mode, the manual adjustment is deleted and the parameterized setpoint temperature for the operating mode plus any change by the base setpoint value object will be applied if this parameter is activated. Example: Comfort temperature of 21°C plus manual adjustment of 1.5°C = 22.5°C. Change to Eco with programmed temperature 17°C. The device regulates the temperature to 17°C, since the manual adjustment is deleted.

If the parameter is deactivated, the manual setpoint adjustment will be added to the temperature in the new operating mode. Example: Comfort temperature of 21°C plus manual adjustment of 1.5°C = 22.5°C. If the system switches to Eco with a parameterized temperature of 17°C, the device regulates the temperature to 18.5°C, since the manual adjustment is added.

10.3.90 Setpoint adjustment - Resetting the manual adjustment via object

Options:	No
	Yes

If this parameter is activated, a separate object can be used to delete the manual adjustment at any time. Example of application: Resetting the manual adjustment on all devices located in a building using a system clock.

10.3.91 Setpoint adjustment - Permanent storage of on-site operation

Options:	No
	Yes

If this parameter is activated, the manual settings for setpoint and, where applicable, fan speed level, as well as the value of the "Basic load" object, will be stored in the device and re-activated after a reset. The same applies to the operating mode.

If the device is re-programmed, the stored setpoint values will also be deleted.

10.3.92 Temperature reading - Inputs of temperature reading

Options:	Internal measurement
	External measurement
	Weighted measurement

The room temperature can be measured at the device or fed to the device by an object via the bus. In addition, weighted measuring is also available, in which the weighted average of up to three temperature values (1 x internal, 2 x external) is calculated and used as an input value for control.

10.3.93 Temperature reading - Inputs of weighted temperature reading

Options:	Internal and external measurement
	2 x external measurement
	Internal and 2x external measurement

Specifies the temperature reading inputs for the weighted measurement, in which the calculated weighted average of the inputs is used as an input value for control

**Note**

This parameter is only available when the "Inputs of temperature reading" parameter is set on "Weighted measurement".

10.3.94 Temperature reading - Weighting of internal measurement (0 to 100%)

Options:	Setting option between 0 - 15
----------	-------------------------------

Specifies the weighting of the internal measurement at a level between 0% and 100%.

**Note**

This parameter is only available when the "Inputs of weighted temperature reading" parameter is set on "Internal and external measurement" or "Internal and 2x external measurement".

10.3.95 Temperature reading - Weighting of external measurement (0 to 100%)

Options:	Setting option between 0 - 15
----------	-------------------------------

Specifies the weighting of the external measurement at a level between 0% and 100%.

**Note**

This parameter is only available when the "Inputs of weighted temperature reading" parameter is set on "Internal and external measurement", "2x external measurement" or "Internal and 2x external measurement".

10.3.96 Temperature reading - Weighting of external measurement 2 (0 to 100%)

Options:	Setting option between 0 - 15
----------	-------------------------------

Specifies the weighting of the external measurement 2 at a level between 0% and 100%. When added together with the (0%...100%) weighting of the external measurement, the result must be 100%.

**Note**

This parameter is only available when the "Inputs of weighted temperature reading" parameter is set on "2x external measurement" or "Internal and 2x external measurement".

10.3.97 Temperature reading - Cyclic sending of the actual temperature (min)

Options:	Setting option between 5 - 240
----------	--------------------------------

The current actual temperature used by the device can be cyclically transmitted to the bus.

10.3.98 Temperature reading - Difference of value for sending the actual temperature (x 0.1°C)

Options:	Setting option between 1 - 100
----------	--------------------------------

If the change in temperature exceeds the parameterized difference between the measured actual temperature and the previous actual temperature that was sent, the changed value will be transmitted.

10.3.99 Temperature reading - Adjustment value for internal temperature measurement (x 0.1°C)

Options:

Setting option between 1 - 100

Every installation location has different physical conditions (interior or exterior wall, lightweight or solid wall, etc.). In order to use the actual temperature at the installation location as a measured value for the device, a temperature measurement must be performed by an external equalised and / or calibrated thermometer at the installation location. The difference between the actual temperature displayed on the device and the actual temperature determined by the external measurement device must be entered in the parameter field as an "Adjustment value".

**Note**

- The calibration measurement should not be carried out immediately after the device has been installed. The device should first adjust to the ambient temperature before calibration is carried out. The calibration measurement should be repeated shortly before or after the room is occupied.
- This parameter is only available when the "Inputs of temperature reading" parameter is set on "Internal measurement" or "Weighted measurement".

10.3.100 Temperature reading - Monitoring time for temperature reading (0 = no monitoring) (min)

Options:

Setting option between 0 - 120

If no temperature is read within the parameterized time period, the device switches to error mode. It transmits a telegram to the bus via the "Actual temperature error" object and applies the operating mode and control value for error (0 - 255) settings.

10.3.101 Temperature reading — Operating mode for fault

Options:

Cooling

Heating

In the event of a failure of the actual temperature measurement, the device will no longer be able to independently specify the heating/cooling operating type. As a result, the operating type best suited to protecting the building will be selected.

**Note**

This parameter is only available when the "Control function" parameter is set on "Heating and cooling" or "heating and cooling with additional stages".

10.3.102 Temperature reading - Control value for fault (0 - 255)

Options:

Setting option between 0 - 255

In the event of a failure of the actual temperature measurement, the device will no longer be able to independently determine the control value. In case of an error, a PWM control (1 Bit) with a fixed cycle time of 15 minutes is used automatically instead of a parameterized 2-point control (1 Bit). In this case the set parameter value is taken into consideration for the control value during an error.

10.3.103 Alarm functions**Note**

This parameter is only available if the "Device function" parameter is set on either "Single device" or "Master device".

10.3.104 Alarm functions - Condensate water alarm

Options:	No
	Yes

If a fan coil is used, condensation may form during operation as a result of excessive cooling and/or humidity. The associated condensate is typically collected in a container. To protect the container against overflowing, and thus prevent potential damage to devices and/or the building, the container alerts the "Condensation alarm" object (receiving only) that the maximum fill level has been exceeded. This causes the controller to switch to a protective mode. This status is indicated by the corresponding icon on devices that have a display. Local operation is blocked. Operation is only possible again after the alarm has been deactivated.

**Note**

This parameter is only available when the "Control function" parameter is set either on "Cooling", "Cooling with additional stage", "Heating and cooling" or "Heating and cooling with additional stages".

10.3.105 Alarm functions — Dew point alarm

Options:	No
	Yes

When refrigerating machines are used, dew may appear on the refrigerant supply lines during operation as a result of excessive cooling and/or humidity. The dew indicator reports the dew formation via the "Dew point alarm" object (receiving only). This causes the controller to switch to a protective mode. This status is indicated by the corresponding icon on devices that have a display. Local operation is blocked. Operation is only possible again after the alarm has been deactivated.

**Note**

This parameter is only available when the "Control function" parameter is set either on "Cooling", "Cooling with additional stage", "Heating and cooling" or "Heating and cooling with additional stages".

10.3.106 Alarm functions - Frost alarm temperature for HVAC and RHCC status (°C)

Options:	Setting option between 0 - 15
----------	-------------------------------

The RHCC status and HVAC objects have a frost alarm bit. If the input temperature of the controller drops below the temperature set in this parameter, then the frost alarm bit is set in the status objects. It is reset when the temperature is exceeded.

10.3.107 Alarm functions - Heat alarm temperature for RHCC status (°C)

Options:	Setting option between 25 - 70
----------	--------------------------------

The RHCC status object has a heat alarm bit. If the input temperature of the controller exceeds the temperature set in this parameter, then the heat alarm bit is set in the status object. It is reset when the temperature falls below the set temperature.

10.3.108 Fan coil settings - Fan speed levels**Note**

This parameter is only available if the "Device function" parameter is set on either "Single device" or "Master device" and the "Control value type" parameter is set on "Fan coil".

10.3.109 Fan coil settings - Fan speed levels Number of fan speed levels

Options:	3 levels
	5 levels

This parameter is used to specify the number of fan speed levels the actuator will use to control the fan of the fan coil.

10.3.110 Fan coil settings - Fan speed levels - Format of the level output

Options:	0..5
	0..255
	1 bit m off n
	1 bit m 1 off n

- *0 to 5*: The level values (0..3 or 0..5) are output in the 1-byte format as the counter values 0..3 or 0..5.
- *0 to 255*: The level values (0..3 or 0..5) are output as percentage values. Example 5-stage fan: The level value 1 is output as 20%, and 5 is output as 100%.
- *1 Bit m from n*: The level values (0..3 or 0..5) are output using 1-bit objects. The number of objects available is the same as the number of fan speed levels. For level 2, for example, the 1-bit fan speed level objects 1 and 2 are output as the value 1, while the other fan speed level objects use the value 0.
- *1 Bit 1 from n*: The level values (0..3 or 0..5) are output using 1-bit objects. The number of objects available is the same as the number of fan speed levels. For the level 2, for example, only the 1-bit fan speed level object 2 is output as the value 1. The other fan speed level objects use the value 0.

10.3.111 Fan coil settings - Fan speed levels - Level output

Options:	For manual operation and automatic
	Only for manual operation

This parameter is used to specify when the output of the fan speed level values will occur: either only when the fan speed levels are manually adjusted or also in automatic mode. This setting depends on the options for the fan coil actuator. If the actuator itself controls the fan speed levels in automatic mode based on a derivative of the control value, then the "Only for manual operation" option must be selected. Otherwise, the other option should be selected.

10.3.112 Fan coil settings - Fan speed levels - Lowest manually adjustable level

Options:	Level 0
	Level 1

This parameter is used to preselect the lowest fan speed level that can be set by an operation performed at the device. When level 0 is selected, the heating/cooling system will not be in operation (fan speed level and valve control 0) as long as the current operating mode and operation type are maintained. To avoid damage to the building, level 0 is deactivated after 18 hours and the device is returned to automatic mode.

10.3.113 Fan coil settings - Fan speed levels - Level status evaluation

Options:	No
	Yes

The controller obtains the current fan speed level for controlling a fan coil actuator either by calculating it from the table of level values under "Fan coil settings for heating" or "Fan coil settings for cooling", or by receiving feedback from the fan coil actuator. If the "Yes" option is selected, the "Fan coil step status" object is activated for receiving the fan speed level from the fan coil actuator.

10.3.114 Fan coil settings heating**Note**

This parameter is only available if the "Device function" parameter is set on either "Single device" or "Master device" and the "Control value type" parameter is set on "Fan coil". In addition, the "Control function" parameter must be set on either "Heating", "Heating with additional stage", "Heating and cooling" or "Heating and cooling with additional stages".

10.3.115 Fan coil settings for heating - Speed level 1 to 5 up to control value (0 to 255) heating

Options:	Setting option between 0 - 255
----------	--------------------------------

In this parameter, the control values of the controller are assigned to fan speed levels. This assignment is used if the fan speed levels are transmitted together with the control values.

**Note**

- These level settings should be adjusted to match the settings in the fan coil actuator.
- Setting the "Control value type" to "Fan coil" in the control parameters is only useful for one of either the basic stage or the additional stage. Setting the basic and additional stage parameters to fan coil is not useful, since the control of only one fan coil actuator each for heating and cooling is supported.
- The "Fan speed level 4 - 5 up to control value (0 - 255) heating" parameters are available only when the "Number of fan speed levels" is set on "5 levels".

10.3.116 Fan coil settings for heating - Fan speed level limit heating for eco mode

Options:	No
	Yes

This parameter limits the fan speed level when the system is switched to eco mode.

10.3.117 Fan coil settings for heating - Maximum speed level heating for eco mode

Options:	Setting option between 0 - 5
----------	------------------------------

Specifies the maximum possible fan speed level when the system is switched to eco mode.

10.3.118 Fan coil settings for cooling**Note**

This parameter is only available if the "Device function" parameter is set on either "Single device" or "Master device" and the "Control value type" parameter is set on "Fan coil". In addition, the "Control function" parameter must be set on either "Cooling", "Cooling with additional stage", "Heating and cooling" or "Heating and cooling with additional stages".

10.3.119 Fan coil settings for cooling - Speed level 1 to 5 up to control value (0 to 255) cooling

Options:	Setting option between 0 - 255
----------	--------------------------------

In this parameter, the control values of the controller are assigned to fan speed levels. This assignment is used if the fan speed levels are transmitted together with the control values.

**Note**

- These level settings should be adjusted to match the settings in the fan coil actuator.
- Setting the "Control value type" to "Fan coil" in the control parameters is only useful for one of either the basic stage or the additional stage. Setting the basic and additional stage parameters to fan coil is not useful, since the control of only one fan coil actuator each for heating and cooling is supported.
- The "Fan speed level 4 - 5 up to control value (0 - 255) cooling" parameters are available only when the "Number of fan speed levels" is set on "5 levels".

10.3.120 Fan coil settings for cooling - Fan speed level limit cooling for eco mode

Options:	No
	Yes

This parameter limits the fan speed level when the system is switched to eco mode.

10.3.121 Fan coil settings for cooling - Maximum fan speed level cooling for eco mode

Options:	Setting option between 0 - 5
----------	------------------------------

Specifies the maximum possible fan speed level when the system is switched to eco mode.

10.3.122 Summer compensation**Note**

This parameter is only available if the "Device function" parameter is set on either "Single device" or "Master device".

10.3.123 Summer compensation - Summer compensation

Options:	No
	Yes

In order to save energy, and to ensure that the temperature difference occurring during entry and exit of a climate-controlled building stays within comfortable limits, the excessive reduction of room temperature should be prevented during high temperatures in the summer (Summer compensation according to DIN 1946). The room temperature is increased by adjusting the setpoint temperature for cooling.

Raising the room temperature does not, however, mean that you heat up the room. Rather, the adjustment is intended to allow the room temperature to increase to a certain setpoint without cooling. This, for example, prevents the air-conditioning system from further reducing the room

temperature to 24°C with an external temperature of 35°C.

However, activation of the summer compensation requires an outside temperature sensor that transmits its measured value to the bus and can be evaluated by the room temperature controller.

The following parameters are available for summer compensation:

- "Lower outside temperature value for summer compensation",
- "Upper outside temperature value for summer compensation",
- "Lower setpoint offset for summer compensation",
- "Upper setpoint offset for summer compensation"

Above the "Upper outside temperature value", the minimum setpoint temperature for cooling is the outside temperature minus the "Upper setpoint offset". The outside temperature has no effect on the minimum setpoint temperature for cooling below the "Lower outside temperature value". Between the "Lower" and "Upper outside temperature value", the minimum setpoint temperature for cooling undergoes floating adjustment by the parameterized setpoint temperature equal to the outside temperature minus the "Lower offset" to a value equal to the outside temperature minus the "Upper setpoint offset" as a function of the outside temperature.

Typical values for summer compensation are:

- 21°C: Lower outside temperature value
- 32°C: Upper outside temperature value
- 0 K: Lower setpoint offset
- 6 K: Upper setpoint offset

This means that a continuous increase of the minimum setpoint value for cooling occurs to a value equal to the outside temperature minus a setpoint offset of 0 to 6 K if the outside temperature increases to 32°C from 21°C.

For example:

For an increasing outside temperature, the minimum setpoint value for cooling will be increased starting at an outside temperature of 21°C. The minimum setpoint temperature for cooling is 25.1°C at an outside temperature of 30°C; 25.5°C at an outside temperature of 31°C; 26°C at an outside temperature of 32°C; and 27°C at an outside temperature of 33°C.

10.3.124 Summer compensation - (Lower) Starting temperature for summer compensation (°C)

Options:

Setting option between -127 - 127

The parameter defines the lower outside temperature value up to which temperature value the setpoint correction (summer compensation) is performed based on too high an outside temperature.



Note

This parameter is only available if the "Summer compensation" parameter is set to "Yes".

10.3.125 Summer compensation - Offset of the set-point temperature for the entry into summer compensation (x 0.1°C)

Options:

Setting option between -127 - 127

The parameter is used to define how many degrees Kelvin the setpoint value will be increased by during summer compensation when the lower temperature value is reached.

Typical values for summer compensation are:

- 20°C: Lower outside temperature value
- 32°C: Upper outside temperature value
- 0 K: Lower setpoint offset
- 4 K: Upper setpoint offset

That means that a flowing setpoint increase of 0 to 4 K occurs if the outside temperature increases from 20°C to 32°C.



Note

This parameter is only available if the "Summer compensation" parameter is set to "Yes".

10.3.126 Summer compensation - (Upper) exit temperature for summer compensation (°C)

Options:

Setting option between -127 - 127

The parameter defines the upper outside temperature value up to which temperature value the setpoint correction (summer compensation) is performed based on too high an outside temperature.



Note

This parameter is only available if the "Summer compensation" parameter is set to "Yes".

10.3.127 Summer compensation - Offset of the set-point temperature for the exit from summer compensation (x 0.1°C)

Options:	Setting option between -127 - 127
----------	-----------------------------------

The parameter is used to define how many degrees Kelvin the setpoint value will be increased by during summer compensation when the upper temperature value is reached.

Typical values for summer compensation are:

- 20°C: Lower outside temperature value
- 32°C: Upper outside temperature value
- 0 K: Lower setpoint offset
- 4 K: Upper setpoint offset

That means that a flowing setpoint increase of 0 to 4 K occurs if the outside temperature increases from 20°C to 32°C.



Note

This parameter is only available if the "Summer compensation" parameter is set to "Yes".

10.4 Additional RTC application "Control settings"

10.4.1 General – Jump-back to the primary function

Options:	5 s
	10 s
	20 s
	30 s
	1 min.
	2 min.
	3 min.

The parameter is used to specify the time period of non-operation after which there is a jump-back to the first function of the control element.

10.4.2 Temperature display – Temperature unit

Options:	°C
	°F

This is where the temperature unit is selected for the display on the device. The parameter is used to choose between Celsius (°C) and Fahrenheit (°F).

10.4.3 General - Setting the temperature unit via object

Options:	No
	Yes

The parameter is used to define whether the temperature unit adjustment is transmitted via an object.

10.4.4 General - Setpoint display

Options:	Absolute setpoint (e.g. 21°C)
	Relative setpoint (e.g. -5°C to +5°C)

The parameter is used to define whether the absolute or the relative setpoint is displayed.

10.4.5 General - Display of actual temperature

Options:	No
	Yes

If the actual temperature is to be shown on the display, the parameter must be set on active. The device will then primarily display the actual temperature. When actuating the control element the display changes to the setpoint adjustment. After non-actuation of the control element the current actual temperature again appears in the display after the set waiting period.

10.4.6 General - Waiting period for display of actual temperature

Options:	5 s
	10 s
	20 s
	30 s
	1 min.
	2 min.
	4 min.

After non-actuation of the control element the current actual temperature again appears in the display after the set waiting period.

10.4.7 General - Display of actual temperature in eco mode

Options:	No
	Yes

If the actual temperature is to be shown in ECO mode on the display, the parameter must be set on active. The device will then primarily display the actual temperature. When actuating the control element the display changes to the setpoint adjustment. After non-actuation of the control element the current actual temperature again appears in the display after the set waiting period.

10.4.8 Brightness setting – Day/Night mode

Options:	No
	Yes

Via the activated communication object "Day/Night" the backlighting of the display is shown bright during day mode and darker during night mode.

**Note**

The operation only applies to the display. It does not apply to the backlighting of the buttons.

10.4.9 Brightness setting – Brightness of display backlighting

Options:	Dark
	Bright

This can be used to define the brightness of the display backlighting independent of day or night mode.

**Note**

This parameter is only available if the "Day/Night mode" parameter is set on "No".

The operation only applies to the display. It does not apply to the backlighting of the buttons.

10.4.10 Extended settings - Colour scheme of display backlighting

Options:	Coloured
	Black and white

The device has a preset colour scheme for the room temperature controller. This means that the display indicates the modes.

- Set-point temperature < actual temperature = orange (warmer, heating)
- Set-point temperature > actual temperature = blue (colder, cooling)
- Set-point temperature = actual temperature = white (warmer, heating)
- ECO mode = green

If the colour concept is not required, the display can be selected in black and white. The display then does not indicate the specific statuses ("Heating" / "Cooling").

**NOTE**

The colour scheme of the display is not available for every version of the device. It is available for the following device versions:

- Millenium, 3,5"
- Busch-*priOn*[®]
- **Busch-ComfortPanel**[®]

10.5 Communication objects - RTC

10.5.1 Heating control value

Number	Name	Object function	Data type
1	Heating control value (control value heating/cooling)	Output	1. Switching 2. Percent (0 to 100%)

Description:

1. This object is used to operate a switching actuating drive, e.g. a thermoelectric positioner, that is controlled by a switching/heating actuator.
2. This object is used to control an actuating drive with a continuous input value (0%..100%), e.g. an electromotive actuating drive.

10.5.2 Additional heating stage

Number	Name	Object function	Data type
2	Additional heating stage (additional heating/cooling stage)	Output	1. Switching 2. Percent (0 to 100%)

Description:

1. This object is used to operate a switching actuating drive, e.g. a thermoelectric positioner, that is controlled by a switching/heating actuator.
2. This object is used to control an actuating drive with a continuous input value (0%..100%), e.g. an electromotive actuating drive.



Note

The additional stage can also be used as a parallel second heating stage. To do this, set the parameter for the temperature difference to the basic stage to 0°C.

10.5.3 Cooling control value

Number	Name	Object function	Data type
3	Cooling control value	Output	1. Switching 2. Percent (0 to 100%)

Description:

1. This object is used to operate a switching actuating drive, e.g. a thermoelectric positioner, that is controlled by a switching/heating actuator.
2. This object is used to control an actuating drive with a continuous input value (0%..100%), e.g. an electromotive actuating drive.

10.5.4 Additional cooling stage

Number	Name	Object function	Data type
4	Additional cooling stage	Output	1. Switching 2. Percent (0 to 100%)

Description:

1. This object is used to operate a switching actuating drive, e.g. a thermoelectric positioner, that is controlled by a switching/heating actuator.
2. This object is used to control an actuating drive with a continuous input value (0%..100%), e.g. an electromotive actuating drive.



Note

The additional stage can also be used as a parallel second cooling stage. To do this, set the parameter for the temperature difference to the basic stage to 0°C.

10.5.5 Control On/Off

Number	Name	Object function	Data type
5	1. Control On/Off	Output	Switching
	2. Control On/Off (master)	Output	Switching
	3. Control On/Off (slave)	Output	Switching

If a 0 telegram is received, the controller switches to OFF mode and regulates the temperature to the setpoint value for frost/heat protection. When the controller is switched on again, the remaining operating mode objects are queried in order to determine the new operating mode.



NOTE

About item 2:

During active ON/OFF controller function in master/slave mode the ON/OFF (master) control object is to be linked with this object.

About item 3: During active ON/OFF controller function in master/slave mode the ON/OFF (slave) control object is to be linked with this object.

10.5.6 Actual temperature

Number	Name	Object function	Data type
6	1. Actual temperature	Output	2-byte floating point value
	2. Actual temperature weighted	Output	2-byte floating point value

1. The object outputs the measured (room) temperature, adjusted by the calibration value.
2. The object outputs the temperature value which is calculated from the recording and weighting of internal and up to two external temperatures.



Note

An external temperature measurement for room control may be practical for larger rooms and/or floor heating.

10.5.7 External actual temperature

Number	Name	Object function	Data type
7	External actual temperature	Input	2-byte floating point value

2-byte communication object for reading an external temperature value provided via the KNX bus.

10.5.8 External actual temperature 2

Number	Name	Object function	Data type
8	External actual temperature 2	Input	2-byte floating point value

2-byte communication object for reading an additional external temperature value provided via the KNX bus.

10.5.9 Fault, actual temperature

Number	Name	Object function	Data type
9	1. Fault, actual temperature	Output	Switching
	2. Fault, actual temperature (master)	Output	Switching
	3. Fault, actual temperature (slave)	Output	Switching

If one of the parameterized input temperatures is unavailable to the controller for a period longer than the monitoring time, the controller enters the error mode. The error mode is sent to the bus as the value 1.

**Note**

About item 2:

This object must be connected to the "Fault, actual temperature (slave)" object in order to indicate the error mode.

About item 3:

This object must be connected to the "Fault, actual temperature (slave)" object in order to indicate the error mode.

10.5.10 Local actual temperature

Number	Name	Object function	Data type
10	Local actual temperature	Output	Switching

Not visible!

10.5.11 Current setpoint

Number	Name	Object function	Data type
11	Current setpoint	Output	2-byte floating point value

The object outputs the current setpoint temperature resulting from the following: the parameterized setpoint temperature of the current operation type and operating mode, the manual setpoint temperature adjustment, a change in the base setpoint temperature via the base setpoint value object. This is purely a transmitting object.

10.5.12 Operating mode

Number	Name	Object function	Data type
12	1. Operating mode	Input / output	HVAC mode
	2. Operating mode (master)	Input / output	HVAC mode
	3. Operating mode (slave)	Input / output	HVAC mode

The "Operating mode" object receives, as a 1-byte value, the operating mode that is to be set. Here value 1 means "Comfort", value 2 "Standby", value 3 "Economy" and value 4 "Frost/heat protection".

In addition to manual setpoint adjustment and the adjustment of the basic setpoint value, the setpoint temperature of the controller can also be defined by objects "Superimposed operating mode", "Condensate ware alarm", "Dew alarm", "Window contact", "Control On/Off", "Presence detector" and "Operating mode (listed in decreasing order of priority).

**Note**

Item 2:

If the master/slave mode is the active operating mode, the Operating mode (slave) object must be connected to this object.

Item 3:

If the master/slave mode is the active operating mode, the operating mode (master) object must be connected to this object.

10.5.13 Superimposed operating mode

Number	Name	Object function	Data type
13	1. Superimposed operating mode	Input	HVAC mode
	2. Superimposed operating mode (master/slave)	Input	HVAC mode

The "Superimposed operating mode" object receives the operating mode that is to be set as 1-byte value. Here value 0 means "Superimposition inactive", value 1 "Comfort", value 2 "Standby", value 3 "Economy" and value 4 "Frost/heat protection".

In addition to manual setpoint adjustment and the adjustment of the basic setpoint value, the setpoint temperature of the controller can also be defined by objects "Superimposed operating mode", "Condensate water alarm", "Dew alarm", "Window contact", "Control On/Off", "Presence detector" and "Operating mode (listed in decreasing order of priority).



Note

Item 2:

If the master/slave mode is active, the "Superimposed operating mode" object of the master and the slave must be connected to the group address of the transmitter.

10.5.14 Window contact

Number	Name	Object function	Data type
14	1. Window contact	Input	Switching
	2. Window contact (master/slave)	Input	Switching

The object uses the value 1 to signal an open window to the controller. If no other object with a higher priority is present, then the "Window contact" message causes the controller to be set to the setpoint value for frost/heat protection. In addition to manual setpoint adjustment and the adjustment of the basic setpoint value, the setpoint temperature of the controller can also be defined by objects "Superimposed operating mode", "Condensate water alarm", "Dew alarm", "Window contact", "Control On/Off", "Presence detector" and "Operating mode (listed in decreasing order of priority).



Note

Item 2:

If the master/slave mode is active, the "Window contact (master/slave)" object of the master and the slave must be connected to the group address of the transmitter.

10.5.15 Presence detector

Number	Name	Object function	Data type
15	1. Presence detector	Input	Switching
	2. Presence detector (master/slave)	Input	Switching

This object transmits the value 1 to the controller to signal that there are people in the room. If not other object with a higher priority is present, then the "Presence detector" causes the controller to be set to the comfort setpoint value. In addition to manual setpoint adjustment and the adjustment of the basic setpoint value, the setpoint temperature of the controller can also be defined by objects "Superimposed operating mode", "Condensate water alarm", "Dew alarm", "Window contact", "Control On/Off", "Presence detector" and "Operating mode (listed in decreasing order of priority).

**Note**

Item 2:

If the master/slave mode is active, the "Presence detector (master/slave)" object of the master and the slave must be connected to the group address of the transmitter.

10.5.16 Heating status

Number	Name	Object function	Data type
16	Heating status	Output	Switching

The room temperature controller sends an ON telegram via the "Heating status" object as soon as it is active in the heating mode. If the controller is in the inactive zone between heating and cooling or is in cooling mode, the room temperature controller transmits an OFF telegram on the "Heating status" object.

10.5.17 Cooling status

Number	Name	Object function	Data type
17	Cooling status	Output	Switching

The room temperature controller sends an ON telegram via the "Cooling status" object as soon as it is active in the cooling mode. If the controller is in the inactive zone between heating and cooling or is in heating mode, the room temperature controller transmits an OFF telegram on the "Cooling status" object.

10.5.18 Basic load

Number	Name	Object function	Data type
16	Basic load	Input / output	Switching

This object uses the value 1 to activate a parameterized base load, i.e. a minimum control value greater than zero. The value 0 deactivates the base load. When the base load is deactivated, the control value can be lowered all the way to zero if necessary when the setpoint temperature is reached, despite the minimum value set in the parameter.

**Note**

Deactivating the basic load for a floor heating system is always useful in the summer, since it saves heating energy.

10.5.19 Switchover heating/cooling

Number	Name	Object function	Data type
17	Switchover heating/cooling	Input / output	Switching

1. **Automatic:** If the switchover between heating and cooling is performed automatically by the room temperature controller, then this object is used to provide information on the current heating (0) or cooling (1) status to the KNX bus. It is a transmitting object.
2. **Only via object:** The switchover between heating and cooling on the room temperature controller occurs solely via this 1-bit communication object. The value (0) activates the heating mode, and the value (1) activates the cooling mode. This is a receiving object.
3. **Manual or via object:** The switchover between heating and cooling on the room temperature controller occurs by user interaction or via the 1-bit communication object. The information on the respective heating (0) or cooling (1) status is available to the KNX bus. This is a receiving and sending object.

10.5.20 Fan coil manual

Number	Name	Object function	Data type
18	1. Fan coil manual	Output	Switching
	2. Fan coil manual (master)	Output	Switching
	3. Fan coil manual (slave)	Output	Switching

Using this 1-bit communication object, a fan coil actuator can be placed in manual fan mode or returned to automatic fan mode. In the automatic fan mode of the fan coil actuator, the fan's rotational speed is defined in the fan coil actuator using the control value. In manual fan operation, the user of the room temperature controller can set the fan's rotational speed as needed. This setting will remain active until it is reset. The fan speed level 0 is an exception: to avoid damage to the building, automatic mode is activated again 18 hours after fan speed level 0 is selected.



Note

Item 2:

If fan coil manual is active in the master/slave mode, the fan coil manual (slave) object must be connected to this object.

Item 3:

If fan coil manual is active in the master/slave mode, the fan coil manual (master) object must be connected to this object.

10.5.21 Fan coil step

Number	Name	Object function	Data type
19	1. Fan coil step	Output	2-byte floating point value
	2. Fan coil step (master)	Output	2-byte floating point value
	3. Fan coil step (slave)	Output	2-byte floating point value

The fan speed level in the fan coil actuator is selected via the 1-byte communication object. Whether the fan speed level information is transmitted in manual or also in automatic fan speed level mode can be set. The formats that can be selected for the 1-byte communication object are the fan speed level (0..5) or a percentage value (0..100%) which is calculated back to a fan speed level in the fan coil actuator.



Note

Item 2:

If fan coil step is active in the master/slave mode, the fan coil step (slave) object must be connected to this object.

Item 3:

If fan coil step is active in the master/slave mode, the fan coil step (slave) object must be connected to this object.

10.5.22 Fan coil step status

Number	Name	Object function	Data type
20	Fan coil step status	Input / output	2-byte floating point value

Using the "Fan coil step status" object, the room temperature controller receives the current fan speed level of the fan coil actuator.

10.5.23 Fan speed level 1

Number	Name	Object function	Data type
21	Fan speed level 1	Output	Switching

This 1-bit communication object is used to output the active status (1) of the fan speed level, while the other fan speed levels are deactivated (0), depending on the parameter setting. If the fan speed level is inactive, the object has a value of (0).

10.5.24 Fan speed level 2

Number	Name	Object function	Data type
22	Fan speed level 2	Output	Switching

This 1-bit communication object is used to output the active status (1) of the fan speed level, while the other fan speed levels are deactivated (0), depending on the parameter setting. If the fan speed level is inactive, the object has a value of (0).

10.5.25 Fan speed level 3

Number	Name	Object function	Data type
23	Fan speed level 3	Output	Switching

This 1-bit communication object is used to output the active status (1) of the fan speed level, while the other fan speed levels are deactivated (0), depending on the parameter setting. If the fan speed level is inactive, the object has a value of (0).

10.5.26 Fan speed level 4

Number	Name	Object function	Data type
24	Fan speed level 4	Output	Switching

This 1-bit communication object is used to output the active status (1) of the fan speed level, while the other fan speed levels are deactivated (0), depending on the parameter setting. If the fan speed level is inactive, the object has a value of (0).

10.5.27 Fan speed level 5

Number	Name	Object function	Data type
25	Fan speed level 5	Output	Switching

This 1-bit communication object is used to output the active status (1) of the fan speed level, while the other fan speed levels are deactivated (0), depending on the parameter setting. If the fan speed level is inactive, the object has a value of (0).

10.5.28 Basic setpoint

Number	Name	Object function	Data type
26	Basic setpoint	Input	2-byte floating point value

This 2-byte communication object can be used to change/adjust the parameterized basic setpoint value via the KNX bus. Parameters can be used to define whether the value received by this object is interpreted as "Setpoint heating comfort", "Setpoint cooling comfort" or an average between heating and cooling comfort.

10.5.29 Resetting manual setpoints

Number	Name	Object function	Data type
27	Resetting manual setpoints	Input	Switching

This 1-bit communication object is used to reset the manual setpoint adjustment that was set on the device.

10.5.30 Dew point alarm

Number	Name	Object function	Data type
28	Dew point alarm	Input	Switching

This 1-bit communication object is used to place the controller in the dew point alarm mode. This causes the current setpoint value to be set to the heat protection setpoint value in order to keep the structure from being damaged by dew.



Note

This protective mechanism is only active in the cooling mode. It remains in place until it is cancelled by the value (0). When an alarm is active, manual operation of the controller is blocked. This information is indicated by a corresponding icon on the control unit.

10.5.31 Condensate water alarm

Number	Name	Object function	Data type
29	1. Condensate water alarm	Input	Switching
	2. Condensate water alarm (master/slave)	Input	Switching

This 1-bit communication object is used to place the controller in the condensation alarm mode. This causes the current setpoint value to be set to the heat protection setpoint value in order to keep the structure from being damaged by an overflowing condensation container.



Note

Item 1:

This protective mechanism is only active in the cooling mode. It remains in place until it is cancelled by the value (0). When an alarm is active, manual operation of the controller is blocked. This information is indicated by a corresponding icon on the device.

Item 2:

- This protective mechanism is only active in the cooling mode. It remains in place until it is cancelled by the value (0). When an alarm is active, manual operation of the controller is blocked. This information is indicated by a corresponding icon on the device.
- When the master/slave mode is active, the condensate water alarm (master/slave) objects must be connected to the alarm transmitter.

10.5.32 Outside temperature for summer compensation

Number	Name	Object function	Data type
30	Outside temperature for summer compensation	Input	2-byte floating point value

In order to save energy, and to ensure that the temperature difference occurring during entry and exit of a climate-controlled building stays within comfortable limits, the reduction of room temperature by cooling devices should be limited as a function of the outside temperature (summer compensation). This, for example, prevents the air-conditioning system from further reducing the room temperature to 24°C with an outside temperature of 35°C.

This function can only be used with an outside temperature sensor. This 2-byte communication object must then be used to provide the controller with the current outside temperature.

10.5.33 Summer compensation active

Number	Name	Object function	Data type
31	Summer compensation active	Output	Switching

This 1-bit communication object is used to indicate via the bus whether the summer compensation is active (1) or inactive (0). If it is active, the setpoint value configured for the cooling mode is increased by the summer compensation function. A decrease of the cooling mode setpoint temperature below the value calculated by the parameterized summer compensation function is not possible. An increase of the setpoint temperature for the cooling mode is always possible.

10.5.34 Setpoint reached

Number	Name	Object function	Data type
32	Setpoint reached	Output	Switching

When the setpoint set on the device in comfort mode has been reached it is sent by means of value (1) as information to the KNX bus via the 1-bit communication object. The function is started by activating the comfort or presence mode. If the reaching of the setpoint temperature is interfered with by the preselection of a different operating mode or by adjustment to a new setpoint, value (0) is sent.

10.5.35 Fahrenheit

Number	Name	Object function	Data type
33	1. Fahrenheit	Input / output	Switching
	2. Fahrenheit (master)	Input / output	Switching
	3. Fahrenheit (slave)	Input / output	Switching

The temperature indication on the display can be changed from Celsius (°C) to Fahrenheit (°F). The conversion from Celsius to Fahrenheit always takes place in the display unit, since only Celsius values are sent over the KNX bus. The value (0) results in a temperature indication in Celsius, while the value (1) results in Fahrenheit.

**NOTE**

Item 2:

If the Fahrenheit object is active in the master/slave mode, the Fahrenheit (slave) object must be connected to this object.

Item 3:

If the Fahrenheit object is active in the master/slave mode, the Fahrenheit (master) object must be connected to this object.

10.5.36 Display backlighting

Number	Name	Object function	Data type
34	Display backlighting	Input / output	Switching

The display backlighting is activated with value (1) and deactivated with value (0) via the 1-bit communication object.

**NOTE**

This function is mainly used in rooms where backlighting during the night is considered to be a disturbing factor, such as in hotel rooms and bedrooms.

10.5.37 On/Off request

Number	Name	Object function	Data type
35	1. On/off request (master)	Input	Switching
	2. On/off request (slave)	Input	Switching

This 1-bit communication object must be connected to the respective slave communication object in order to synchronise the devices in the master/slave configuration.

10.5.38 Setpoint display

Number	Name	Object function	Data type
36	1. Set value display (master)	Input / output	2-byte floating point value
	2. Set value display (slave)	Input / output	2-byte floating point value

This 2-byte communication object must be connected to the respective slave communication object in order to synchronise the devices in the master/slave configuration.

10.5.39 Request setpoint

Number	Name	Object function	Data type
37	1. Request set value (master)	Input	Percent (0 - 100%)
	2. Request set value (slave)	Input	Percent (0 - 100%)

This 1-byte communication object must be connected to the respective slave communication object in order to synchronise the devices in the master/slave configuration.

10.5.40 Confirm setpoint

Number	Name	Object function	Data type
38	1. Confirm set value (master)	Input / output	Percent (0 - 100%)
	2. Confirm set value (slave)	Input / output	Percent (0..100%)

This 1-byte communication object must be connected to the respective slave communication object in order to synchronise the devices in the master/slave configuration.

10.5.41 Heating/cooling request

Number	Name	Object function	Data type
39	1. Heating/cooling request (master)	Input	Switching
	2. Heating/cooling request (slave)	Input	Switching

This 1-bit communication object must be connected to the respective slave communication object in order to synchronise the devices in the master/slave configuration.

10.5.42 Request fan speed level manually

Number	Name	Object function	Data type
40	1. Request fan speed level manually (master)	Input	Switching
	2. Request fan speed level manually (slave)	Input	Switching

This 1-bit communication object must be connected to the respective slave communication object in order to synchronise the devices in the master/slave configuration.

10.5.43 Request fan speed level

Number	Name	Object function	Data type
41	1. Request fan speed level (master)	Input	Percent (0..100%)
	2. Request fan speed level (slave)	Input	Percent (0..100%)

This 1-byte communication object must be connected to the respective slave communication object in order to synchronise the devices in the master/slave configuration.

10.5.44 Confirm fan speed level

Number	Name	Object function	Data type
42	1. Confirm fan speed level (master)	Input / output	Percent (0..100%)
	2. Confirm fan speed level (slave)	Input / output	Percent (0..100%)

This 1-byte communication object must be connected to the respective slave communication object in order to synchronise the devices in the master/slave configuration.

10.5.45 Controller status RHCC

Number	Name	Object function	Data type
43	Controller status RHCC	Output	2-byte floating point value

This communication object outputs the heating/cooling operation type, active/inactive operation, the frost and heat alarm, and the error (actual temperature reading failure) in accordance with the specification for the RHCC (Room Heating Cooling Controller) status.

10.5.46 Controller status HVAC

Number	Name	Object function	Data type
44	1. Controller status HVAC	Output	Percent (0..100%)
	2. Controller status HVAC (master)	Output	Percent (0..100%)
	3. Controller status HVAC (slave)	Output	Percent (0..100%)

This communication object outputs the current operating mode, the heating/cooling mode, active/inactive mode, the frost alarm and the dew point alarm in accordance with the specification for the HVAC (Heating Ventilation Air Conditioning) status.



Note

Item 2:

If the master/slave mode is active, the HVAC status (slave) object must be connected to this object.

Item 3:

If the master/slave mode is active, the HVAC status (master) object must be connected to this object.

10.5.47 Commissioned

Number	Name	Object function	Data type
45	Commissioned	Output	Switching

The controller uses this 1-bit communication object to send a cyclical "sign of life". This signal can be used to monitor the device, e.g. by means of a visualisation.

10.6 Additional RTC communication objects "Control settings"

10.6.1 Day/Night mode

Number	Name	Object function	Data type
47	Day/Night mode	–	Switching

Description:

Via the activated communication object "Day/Night" the backlighting of the display is shown bright during day mode and darker during night mode.

Note: The operation only applies to the display. It does not apply to the backlighting of the buttons.

10.7 Application for "Button top right"**10.7.1 Application "1-button switching"**

When actuated or released a switching telegram is sent out. In each case, the application makes a separate set of parameters and communication objects available for the 1st and the 2nd button. The other side of the button can be assigned a further "button-oriented" function.

Parameter

General parameter	Setting options	Comments
Reaction on rising edge	<ul style="list-style-type: none"> ▪ On ▪ Off ▪ Alternating on/off ▪ No reaction 	–
Reaction on falling edge	<ul style="list-style-type: none"> ▪ On ▪ Off ▪ Alternating on/off ▪ No reaction 	–

Objects

No.	Object name	Data type	Flags
0	Switching	1 bit EIS1 / DPT 1.001	C, W ,T ,U

10.7.2 Application "1-button dimming"

The push-buttons have communication objects for switching and dimming. A distinction is made between a short (switching) and long (dimming) press of the button. In each case, the application makes a separate set of parameters and communication objects available for the 1st and the 2nd button. The application allows a lamp to be dimmed with the one button and the other button to be assigned with other "button-oriented" functions.

Parameter

General parameter	Setting options	Comments
Duration of long operation (s)	Time input from 0.3 to 3.0 seconds	General
Working mode of the buttons for switching	<ul style="list-style-type: none"> ▪ Deactivated ▪ Off ▪ On ▪ Alternating on/off 	Advanced
Working mode of the buttons for dimming	<ul style="list-style-type: none"> ▪ Alternating brighter/darker ▪ Darker ▪ Brighter 	

Objects

No.	Object name	Data type	Flags
0	Switching	1 bit EIS2 / DPT 1.001	C, W ,T ,U
1	Relative dimming	4 bit EIS2 / DPT 3.007	C, T

10.7.3 Application "2-button value transmitter"

With an actuation of the 1st or 2nd button a telegram with a predefined value is sent out. The application differentiates here between whether the 1st or 2nd button is actuated.

Parameter

General parameter	Setting options	Comments
Object type	<ul style="list-style-type: none"> ▪ 1 bit ▪ 1 byte 0 - 100% ▪ 1 byte 0 - 255 ▪ 2-byte float ▪ 2-byte signed ▪ 2-byte unsigned ▪ 4-byte float ▪ 4-byte signed ▪ 4-byte unsigned 	-
Working mode of the buttons	<ul style="list-style-type: none"> ▪ 1st button value 1, 2nd button value 2 ▪ 1st button value 2, 2nd button value 1 ▪ Alternating value1/value2 	
Value 1	For 1 bit	<ul style="list-style-type: none"> ▪ On ▪ Off
	For 1 byte 0 - 100%	0 - 100%
	For 1 byte 0 - 255	0 - 255
	For 2-byte float	-671088.6 - +670760.9
	For 2-byte signed	-32768 - +32767
	For 2-byte unsigned	0 - 65535
	For 4-byte float	-4000000 - +4000000
	For 4-byte signed	2147483648 - 2147483647
	For 4-byte unsigned	0 - 4294967295
Value 2	For 1 bit	<ul style="list-style-type: none"> ▪ On ▪ Off
	For 1 byte 0 - 100%	0 - 100%
	For 1 byte 0 - 255	0 - 255
	For 2-byte float	-671088.6 - +670760.9
	For 2-byte signed	-32768 - +32767
	For 2-byte unsigned	0 - 65535
	For 4-byte float	-4000000 - +4000000
	For 4-byte signed	2147483648 - 2147483647
	For 4-byte unsigned	0 - 4294967295

Objects

No.	Object name	Data type	Flags
0	Switching value (1 bit)	1 bit EIS1 / DPT 1.001	C, W ,T ,U
	Switching value (1 byte 0 - 100%)	1 byte EIS6 / DPT 5.001	C, W ,T ,U
	Switching value (1 byte 0 - 255)	1 byte EIS14 / DPT 5.010	C, W ,T ,U
	Switching value (2-byte float)	2 byte EIS5 / DPT 9.xxx	C, W ,T ,U
	Switching value (2-byte signed)	2 byte EIS10 / DPT 7.001	C, W ,T ,U
	Switching value (2-byte unsigned)	2 byte EIS10 / DPT 8.001	C, W ,T ,U
	Switching value (4-byte float)	4 byte EIS9 / DPT 14.xxx	C, W ,T ,U
	Switching value (4-byte signed)	4 byte EIS11 / DPT 13.001	C, W ,T ,U
	Switching value (4-byte unsigned)	4 byte EIS11 / DPT 12.001	C, W ,T ,U

10.7.4 Application "1-button value transmitter, 2 objects"

When actuating and/or releasing the buttons, two telegrams with predefined values are sent from two different communication objects. In each case, the application makes a separate set of parameters and communication objects available for the 1st and the 2nd button. The application makes it possible, for example, to send out a switching function and a floating point value when actuating one side of the button and to assign an additional "button-oriented" function to the other side of the button.

Parameter

General parameter	Setting options	Comments
Objcet type for rising edge	1 bit 1 byte 0 - 100% 1 byte (0 - 255) 2-byte float 2-byte signed 2-byte unsigned 4-byte float 4-byte signed 4-byte unsigned	–
Objcet type for falling edge	1 bit 1 byte 0 - 100% 1 byte (0 - 255) 2-byte float 2-byte signed 2-byte unsigned 4-byte float 4-byte signed 4-byte unsigned	–

Description of application and parameters

Application for "Button top right"

Additional Parameters	Setting options	Comments
Reaction on rising edge	No reaction Value 1 Value 2 Alternating value1/value2	–
Reaction on falling edge	No reaction Value 1 Value 2 Alternating value1/value2	–
Value 1 / 2 for a rising edge	–	Only available when parameter "Reaction to rising edge" is set on "Alternating value 1 / value 2".
	For 1 bit	<ul style="list-style-type: none"> ▪ On ▪ Off
	For 1 byte 0 - 100%	0 - 100 %
	For 1 byte 0 - 255	0 - 255
	For 2-byte float	-671088.6 - +670760.9
	For 2-byte signed	-32768 - +32767
	For 2-byte unsigned	0 - 65535
	For 4-byte float	-4000000 - +4000000
	For 4-byte signed	2147483648 - 2147483647
	For 4-byte unsigned	0 - 4294967295
Value 1 / 2 for falling edge	–	Only available when parameter "Reaction to falling edge" is set on "Alternating value 1 / value 2".
	For 1 bit	<ul style="list-style-type: none"> ▪ On ▪ Off
	For 1 byte 0 - 100%	0 - 100%
	For 1 byte 0 - 255	0 - 255
	For 2-byte float	-671088.6 - +670760.9
	For 2-byte signed	-32768 - +32767
	For 2-byte unsigned	0 - 65535
	For 4-byte float	-4000000 - +4000000
	For 4-byte signed	2147483648 - 2147483647
	For 4-byte unsigned	0 - 4294967295

Objects

No.	Object name	Data type	Flags
0	Switching (rising edge) (1 bit)	1 bit EIS1 / DPT 1.001	C, W ,T ,U
	Switching (rising edge) (1-byte 0 - 100%)	1 byte EIS6 / DPT 5.001	C, W ,T ,U
	Switching (rising edge) (1-byte 0 - 255)	1 byte EIS14 / DPT 5.010	C, W ,T ,U
	Switching (rising edge) (2-byte float)	2 byte EIS5 / DPT 9.xxx	C, W ,T ,U
	Switching (rising edge) (2-byte signed)	2 byte EIS10 / DPT 7.001	C, W ,T ,U
	Switching (rising edge) (2-byte unsigned)	2 byte EIS10 / DPT 8.001	C, W ,T ,U
	Switching (rising edge) (4-byte float)	4 byte EIS9 / DPT 14.xxx	C, W ,T ,U
	Switching (rising edge) (4-byte signed)	4 byte EIS11 / DPT 13.001	C, W ,T ,U
	Switching (rising edge) (4-byte unsigned)	4 byte EIS11 / DPT 12.001	C, W ,T ,U
1	Switching (falling edge) (1 bit)	1 bit EIS1 / DPT 1.001	C, W ,T ,U
	Switching (falling edge) (1-byte 0 - 100%)	1 byte EIS6 / DPT 5.001	C, W ,T ,U
	Switching (falling edge) (1-byte 0 - 255)	1 byte EIS14 / DPT 5.010	C, W ,T ,U
	Switching (falling edge) (2-byte float)	2 byte EIS5 / DPT 9.xxx	C, W ,T ,U
	Switching (falling edge) (2-byte signed)	2 byte EIS10 / DPT 7.001	C, W ,T ,U
	Switching (falling edge) (2-byte unsigned)	2 byte EIS10 / DPT 8.001	C, W ,T ,U
	Switching (falling edge) (4-byte float)	4 byte EIS9 / DPT 14.xxx	C, W ,T ,U
	Switching (falling edge) (4-byte signed)	4 byte EIS11 / DPT 13.001	C, W ,T ,U
	Switching (falling edge) (4-byte unsigned)	4 byte EIS11 / DPT 12.001	C, W ,T ,U

10.7.5 Application "1-button light scene extension unit with memory function"

When a button is actuated a predefined light scene number is called up. In each case, the application makes a separate set of parameters and communication objects available for the 1st and the 2nd button. The application makes it possible to call up a light scene via one button side while the other button side can be assigned with a further "button-oriented" function. The user has the option to trigger a light scene memory command via a long actuation of the button.

Parameter

General parameter	Setting options	Comments
Duration of long operation (s)	Time input from 0.3 to 10.0 seconds	Only available when parameter "Light scene memory function" is set on "Activated".
Light scene memory function	<ul style="list-style-type: none"> ▪ Deactivated ▪ Activated 	–
Number of light scene	1 - 64	–

Objects

No.	Object name	Data type	Flags
0	Number of light scene	18.001 DPT_Scene_Control	C, W ,T ,U

10.7.6 Application "1-button step switch"

Different switching processes are triggered with each new actuation of the 1st or 2nd button.

For example:

- First actuation (2nd button) switches lamp 1 on.
- Second actuation (2nd button) switches lamp 1 off and lamp 2 on.
- Third actuation (2nd button) switches lamp 2 off and lamp 3 on.
- Fourth actuation (1st button) switches lamp 3 off and lamp 2 on.
- Fifth actuation (1st button) switches lamp 2 off and lamp 1 on.
- etc.

Up to five switching levels can be activated.

The application differentiates between whether the 1st or 2nd button was actuated. Depending on the setting, one lower or one higher level can be switched to.

Parameter

General parameter	Setting options	Comments
Number of objects	1 - 5	–
Evaluation period (s)	1.0 - 5.0	–

Additional Parameters	Setting options	Comments
Working mode of the buttons	<ul style="list-style-type: none"> ▪ 1st button Up, 2nd button Down ▪ 1st button Down, 2nd button Up 	–
Sending of objects	<ul style="list-style-type: none"> ▪ At actuation ▪ At change of value 	–
Object values	<ul style="list-style-type: none"> ▪ Normal ▪ Inverse 	–
Bit pattern of the object values	<ul style="list-style-type: none"> ▪ 1 off n ▪ x off n 	–

Objects

No.	Object name	Data type	Flags
0	Switching step 1	1 bit EIS1 / DPT 1.001	C, W, T
1	Switching step 2	1 bit EIS1 / DPT 1.001	C, W, T
2	Switching step 3	1 bit EIS1 / DPT 1.001	C, W, T
3	Switching step 4	1 bit EIS1 / DPT 1.001	C, W, T
4	Switching step 5	1 bit EIS1 / DPT 1.001	C, W, T

10.7.7 Application "1-button short-long operation"

The application makes two separate functions available on one side of the button which can be called up via a short or long button press, while the other side of the button can be assigned a further "button-oriented" function. In each case, the application makes a separate set of parameters and communication objects available for the 1st and the 2nd button.

Parameter

General parameter	Setting options	Comments
Object type	<ul style="list-style-type: none"> ▪ 1 bit ▪ 1 byte 0 - 100% ▪ 1 byte 0 - 255 ▪ 2-byte float ▪ 2-byte signed ▪ 2-byte unsigned ▪ 4-byte float ▪ 4-byte signed ▪ 4-byte unsigned 	General
Reaction on short operation	<ul style="list-style-type: none"> ▪ No reaction ▪ Value 1 ▪ Value 2 ▪ Alternating value1/value2 	
Reaction on long operation	<ul style="list-style-type: none"> ▪ No reaction ▪ Value 1 ▪ Value 2 ▪ Alternating value1/value2 	
Duration of long operation (s)	Time input from 0.3 to 3.0 seconds	Advanced

Objects

No.	Object name	Data type	Flags
0	Switching value for short operation	4 byte EIS14 / DPT 12.001	C, W ,T ,U
1	Switching value for long operation	4 byte EIS14 / DPT 12.001	C, W ,T ,U

10.8 Application "General functions"**10.8.1 Cyclic telegram**

Via the "Cyclic telegram" application and after receipt of a telegram on the "Input" object, a telegram with the same volume is cyclically sent out on the "Cyclic output" object. The object types for "Input" and "Output" can be collectively parameterised for the different applications. The times for cyclic sending on the "Output" object are adjustable. An additional "Enable" object provides the option of temporarily blocking the function.

Cyclic telegram objects

No.	Object name	Data type	Flags
0	Input (1-bit switching)	1 bit EIS1 / DPT 1.001	C, W
	Input (1-bit alarm)	1 bit EIS1 / DPT 1.001	C, W
	Input (1-byte 0 - 100%)	1 byte EIS6 / DPT 5.001	C, W
	Input (1-byte 0 - 255)	1 byte EIS14 / DPT 5.010	C, W
	Input (2-byte float)	2 byte EIS5 / DPT 9.xxx	C, W
	Input (2-byte signed)	2 byte EIS10 / DPT 8.001	C, W
	Input (2-byte unsigned)	2 byte EIS10 / DPT 7.001	C, W
	Input (2-byte temperature)	2 byte EIS5 / DPT 9.001	C, W
	Input (4-byte float)	4 byte EIS9 / DPT 14.xxx	C, W
	Input (4-byte signed)	4 byte EIS11 / DPT 13.001	C, W
	Input (4-byte unsigned)	4 byte EIS11 / DPT 12.001	C, W
1	Output (1-bit switching)	1 bit EIS1 / DPT 1.001	C, T
	Output (1-bit alarm)	1 bit EIS1 / DPT 1.001	C, T
	Output (1-byte 0 - 100%)	1 byte EIS6 / DPT 5.001	C, T
	Output (1-byte 0 - 255)	1 byte EIS14 / DPT 5.010	C, T
	Output (2-byte float)	2 byte EIS5 / DPT 9.xxx	C, T
	Output (2-byte signed)	2 byte EIS10 / DPT 8.001	C, T
	Output (2-byte unsigned)	2 byte EIS10 / DPT 7.001	C, T
	Output (2-byte temperature)	2 byte EIS5 / DPT 9.001	C, T
	Output (4-byte float)	4 byte EIS9 / DPT 14.xxx	C, T
	Output (4-byte signed)	4 byte EIS11 / DPT 13.001	C, T
	Output (4-byte unsigned)	4 byte EIS11 / DPT 12.001	C, T
2	Enable	1 bit EIS1 / DPT 1.001	C, W

10.8.2 Priority

The "Priority" application has 3 communication objects, a 1-bit object "Switch input", a 2-bit object "Input priority" and a 1-bit object "Output". The telegrams received on the "Switch input" are transferred to the "Output" depending on the state of the "Input priority" object.

The 2-bit object "Input priority" can receive and differentiate between four different values (0, 1, 2 and 3). Here, the "Output" object is positively driven. Three different states are differentiated:

- "Input priority" has value "3": the value that is present on "Switch input" has no meaning. The "Output" is switched to positively driven and has the value "1".
- "Input priority" has the value "2". The value that is present on "Switch input" has no meaning. The "Output" is switched off positively driven and has the value "0".
- "Input priority" has the value "1" or "0". The "Output" is not positively driven. The "Switch input" is linked to the status bit of the priority object OR and transferred to the "Output".

During a positive drive, changes of the "Switch input" object are saved, even if the current state on the "Output" object does not immediately change through this. If the positive drive is terminated, a telegram transmission on the "Output" occurs according to the current value of the "Switch input" object.

Priority objects

No.	Object name	Data type	Flags
0	Switch input	1 bit EIS1 / DPT 1.001	C, W
1	Priority input	2 bit EIS8 / DPT 2.001	C, W
2	Output	1 bit EIS1 / DPT 1.001	C, T

10.8.3 Logic**Logic objects**

No.	Object name	Data type	Flags
0	Output (1 bit)	1 bit EIS1 / DPT 1.001	C, W, T
	Output (1 byte)	1 byte EIS14 / DPT 5.010	C, W, T
1	Input 1 (1 bit)	1 bit EIS1 / DPT 1.001	C, W, U
	Input 1 (1 byte)	1 byte EIS14 / DPT 5.010	C, W, U
2	Input 2 (1 bit)	1 bit EIS1 / DPT 1.001	C, W, U
	Input 2 (1 byte)	1 byte EIS14 / DPT 5.010	C, W, U
3	Input 3 (1 bit)	1 bit EIS1 / DPT 1.001	C, W, U
	Input 3 (1 byte)	1 byte EIS14 / DPT 5.010	C, W, U
4	Input 4 (1 bit)	1 bit EIS1 / DPT 1.001	C, W, U
	Input 4 (1 byte)	1 byte EIS14 / DPT 5.010	C, W, U
5	Input 5 (1 bit)	1 bit EIS1 / DPT 1.001	C, W, U
	Input 5 (1 byte)	1 byte EIS14 / DPT 5.010	C, W, U
6	Input 6 (1 bit)	1 bit EIS1 / DPT 1.001	C, W, U
	Input 6 (1 byte)	1 byte EIS14 / DPT 5.010	C, W, U
7	Input 7 (1 bit)	1 bit EIS1 / DPT 1.001	C, W, U
	Input 7 (1 byte)	1 byte EIS14 / DPT 5.010	C, W, U
8	Input 8 (1 bit)	1 bit EIS1 / DPT 1.001	C, W, U
	Input 8 (1 byte)	1 byte EIS14 / DPT 5.010	C, W, U
9	Input 9 (1 bit)	1 bit EIS1 / DPT 1.001	C, W, U
	Input 9 (1 byte)	1 byte EIS14 / DPT 5.010	C, W, U
10	Input 10 (1 bit)	1 bit EIS1 / DPT 1.001	C, W, U
	Input 10 (1 byte)	1 byte EIS14 / DPT 5.010	C, W, U

10.8.4 Gate

The "Gate" application allows specific signals to be filtered and the signal flow to be temporarily blocked. The function has three communication objects: "Control input", "Input" and "Output".

The input or output object can assume different sizes.

The bit size can be freely assigned with the "Not assigned" setting. This means that the first internal or external group address/action that is assigned and already connected to some other communication object will specify the size.

The control can occur from "Input to output" or also from "Output to input", provided the control input allows this. Enabling via the control input can occur via an ON or an OFF telegram.

If, for example, the "Control input" setting is set to "ON telegram", only telegrams from the input are transmitted to the output, if prior to this the control input has received an ON telegram.

It is also possible to block signals via the "Filter function" setting. Either "nothing is filtered out" or the signal "ON is filtered out" or the signal "OFF is filtered out". This function is always necessary, for example, when only the ON telegram is interesting for a sensor and the sensor does not offer any filter function in its application program.

Gate objects

No.	Object name	Data type	Flags
0	Input	–	C, W, T
1	Output	–	C, W, T
2	Control input	1 bit EIS1 / DPT 1.001	C, W

10.8.5 Staircase lighting

With the "Staircase lighting" application, switching telegrams or value telegrams can be provided with a switch-off delay. Depending on the parameterisation, the application shows different communication objects:

- a 1-bit object for input and output

If an ON telegram is received via the "Input/Output" object, the switch-off delay is started immediately. This can be a switch-off delay of 10 seconds to 88:45 minutes, which is adjustable in 1-second steps. After expiration of the switch-off delay, the "Input/Output" object sends an OFF telegram.

- two 1-bit objects for input and output
- two 1-byte objects for input and output

If a telegram is received via the "Input" object, the switch-off delay is started immediately and a telegram with the same value of the telegram received on the input is sent out on the "Output" object. This can be a switch-off delay of 10 seconds to 88:45 minutes, which is adjustable in 1-second steps. After expiration of the switch-off delay, the "Output" object sends out an OFF telegram (1-bit) or a telegram with the value "0" (1-byte).

Via two additional communication objects, it is possible to specify the switch-off delay and the switch-off prewarning time. The values received are written to the memory of the device and are retained even after a power failure and subsequent return of voltage.

Staircase lighting objects

No.	Object name	Data type	Flags
0	Input (1 bit)	1 bit EIS1 / DPT 1.001	C, W
	Input (1 byte)	1 bit EIS14 / DPT 5.010	C, W
	Input_output (1 bit)	1 bit EIS1 / DPT 1.001	C, W, T
1	Switch-off delay (2 byte)	2 byte EIS10 / DPT 7.001	C, R, W
2	Switch-off prewarning (2 byte)	2 byte EIS10 / DPT 7.001	C, R, W
3	Output (1 bit)	1 bit EIS1 / DPT 1.001	C, T
	Output (1 byte)	1 bit EIS14 / DPT 5.010	C, T

10.8.6 Delay

Telegrams can be received via the "Input" object using the "Delay" application. The telegrams received are sent out on the "Output" object with a set delay time.

The object types for "Input" and "Output" can be collectively parameterised for the different applications.

Delay objects

No.	Object name	Data type	Flags
0	Input (1 bit)	1 bit EIS1 / DPT 1.001	C, W
	Input (1 bit)	1 bit EIS7 / DPT 1.008	C, W
	Input (1 bit)	1 bit EIS7 / DPT 1.007	C, W
	Input (1-byte 0 - 100%)	1 byte EIS6 / DPT 5.001	C, W
	Input (1-byte 0 - 255)	1 byte EIS14 / DPT 5.010	C, W
	Input (2-byte float)	2 byte EIS5 / DPT 9.xxx	C, W
	Input (2-byte signed)	2 byte EIS10 / DPT 8.001	C, W
	Input (2-byte unsigned)	2 byte EIS10 / DPT 7.001	C, W
	Input (4-byte float)	4 byte EIS9 / DPT 14.xxx	C, W
	Input (4-byte signed)	4 byte EIS11 / DPT 13.001	C, W
	Input (4-byte unsigned)	4 byte EIS11 / DPT 12.001	C, W
	1	Output (1 bit)	1 bit EIS1 / DPT 1.001
Output (1 bit)		1 bit EIS7 / DPT 1.008	C, T
Output (1 bit)		1 bit EIS7 / DPT 1.007	C, T
Output (1-byte 0 - 100%)		1 byte EIS6 / DPT 5.001	C, T
Output (1-byte 0 - 255)		1 byte EIS14 / DPT 5.010	C, T
Output (2-byte float)		2 byte EIS5 / DPT 9.xxx	C, T
Output (2-byte signed)		2 byte EIS10 / DPT 7.001	C, T
Output (2-byte unsigned)		2 byte EIS10 / DPT 7.001	C, T
Output (4-byte float)		4 byte EIS9 / DPT 14.xxx	C, T
Output (4-byte signed)		4 byte EIS11 / DPT 13.001	C, T
Output (4-byte unsigned)		4 byte EIS11 / DPT 12.001	C, T
2		Delay time (2 byte)	2 byte EIS10 / DPT 7.001

10.8.7 Min/Max value transducer

Up to eight input values can be compared with each other using the "Min/max value transducer" application. The application can output the highest input value, the smallest input value or the average of all input values on the output.

The size of the input objects, and with it also the size of the output object can be adapted for the most diverse applications. You can select from the following object types:

- 1-byte 0 - 100%, for comparison of percentage values
- 1-byte 0 - 255, for the comparison of decimal values between 0 and 255
- 2-byte float, for the comparison of 2-byte floating point values (physical values such as temperature, brightness value, etc.)
- 2-byte signed, for the comparison of decimal values between -32,768 and +32,767
- 2-byte unsigned, for the comparison of decimal values between 0 and 65,535
- 4-byte float, for the comparison of 4-byte floating point values (physical values such as acceleration, electrical current, work, etc.)
- 4-byte signed, for the comparison of decimal values between -2,147,483,648 and 2,147,483,647
- 4-byte unsigned, for the comparison of decimal values between 0 and 4,294,967,295

**NOTE**

With whole numbers the average value is rounded.

Min/Max value transducer objects

No.	Object name	Data type	Flags
0	Output (1-byte 0 - 100%)	1 byte EIS6 / DPT 5.001	C, T
	Output (1-byte 0 - 255)	1 byte EIS14 / DPT 5.010	C, T
	Output (2-byte float)	2 byte EIS5 / DPT 9.xxx	C, T
	Output (2-byte signed)	2 byte EIS10 / DPT 8.001	C, T
	Output (2-byte unsigned)	2 byte EIS10 / DPT 7.001	C, T
	Output (4-byte float)	4 byte EIS9 / DPT 14.xxx	C, T
	Output (4-byte signed)	4 byte EIS11 / DPT 13.001	C, T
	Output (4-byte unsigned)	4 byte EIS11 / DPT 12.001	C, T
1 - 10	Input 1 [2 - 8] (1-byte 0 - 100%)	1 byte EIS6 / DPT 5.001	C, W
	Input 1 [2 - 8] (1-byte 0 - 255)	1 byte EIS14 / DPT 5.010	C, W
	Input 1 [2 - 8] (2-byte float)	2 byte EIS5 / DPT 9.xxx	C, W
	Input 1 [2 - 8] (2-byte signed)	2 byte EIS10 / DPT 8.001	C, W
	Input 1 (2-byte unsigned)	2 byte EIS10 / DPT 7.001	C, W
	Input 1 [2 - 8] (4-byte float)	4 byte EIS9 / DPT 14.xxx	C, W
	Input 1 [2 - 8] (4-byte signed)	4 byte EIS11 / DPT 13.001	C, W
	Input 1 [2 - 8] (4-byte unsigned)	4 byte EIS11 / DPT 12.001	C, W

10.8.8 Threshold value / hysteresis

With the "Threshold value / Hysteresis" application, value telegrams can be received on an input communication object and compared with threshold values specified in the device.

Predefined values are sent out on the "Output" communication object if the upper threshold is exceeded or the lower threshold drops below the set value. The size of the object can be adjusted for different applications.

The function can be temporarily blocked via an enable object.

If the value of the lower threshold lies above the value for the upper threshold, the function is not executed.

Threshold value / hysteresis objects

No.	Object name	Data type	Flags
0	Input (1-byte 0 - 100%)	1 byte EIS6 / DPT 5.001	C, W
	Input (1-byte 0 - 255)	1 byte EIS14 / DPT 5.010	C, W
	Input (2-byte float)	2 byte EIS5 / DPT 9.xxx	C, W
	Input (2-byte signed)	2 byte EIS10 / DPT 8.001	C, W
	Input (2-byte unsigned)	2 byte EIS10 / DPT 7.001	C, W
	Input (4-byte float)	4 byte EIS9 / DPT 14.xxx	C, W
	Input (4-byte signed)	4 byte EIS11 / DPT 12.001	C, W
	Input (4-byte unsigned)	4 byte EIS11 / DPT 13.001	C, W
1	Output (1 bit)	1 bit EIS1 / DPT 1.001	C, T
	Output (1-byte 0 - 100%)	1 byte EIS6 / DPT 5.001	C, T
	Output (1-byte 0 - 255)	1 byte EIS14 / DPT 5.010	C, T
2	Enable	1 bit EIS1 / DPT 1.001	C, W

10.8.9 Light scene actuator

With the "Light scene actuator" application it is possible to call up scenes that are stored in the device via the receipt of a scene number on the 1-byte communication object "Scene call-up". A maximum of eight scenes with up to eight actuator objects can be created.

For triggering different actuators, the size of the actuator groups communication objects can be set under the "Actuator group type" parameter.

The user has the option of saving the scenes himself. A corresponding save telegram must be received for this (see the description of the individual parameters).

Light scene actuator objects

No.	Object name	Data type	Flags
0	Light scene call-up (1 byte)	1 byte / DPT18.001	C, W, U
1 - 10	Actuator group A [B - J] (1-bit switching)	1 bit EIS1 / DPT 1.001	C, W, T, U
	Actuator group A [B - J] (1-bit blind)	1 bit EIS7 / DPT 1.008	C, W, T, U
	Actuator group A [B - J] (1 byte 0 - 100%)	1 byte EIS6 / DPT 5.001	C, W, T, U
	Actuator group A [B - J] (1-byte light scene number)	1 byte / DPT 18.001	C, W, T, U
	Actuator group A [B - J] (Temperature value absolute)	2 byte EIS5 / DPT 9.001	C, W, T, U
10 - 19	Enable scene 1 [Scene 2 - Scene 10]	1 bit EIS1 / DPT 1.001	C, W, T

11 Information about planning and application

11.1 Room air quality

11.1.1 Good air

"Good air" is required in order to ensure efficient working, comfort and a healthy environment. In the same way, a sense of well-being and the ability to concentrate in the workplace are also highly dependent on a good level of room air quality. However, the air quality in schools, conference rooms, hospitals and offices in particular is often not up to this standard. It is primarily affected by three factors: the CO₂ content in the air, the air humidity and the temperature.

11.1.2 KNX room climate control

If a room climate control system is in place, it is possible to record and control the factors affecting whether the room air is of good quality. In this case, the KNX bus is provided with data relating to air quality and room temperature control. If the CO₂ concentration level in the room is too high, for example, it is possible to have ventilators switched on or windows opened automatically. The air quality in the room is constantly recorded and monitored. There is no need to intervene in the process – everything happens automatically.

A room climate control system is often used in rooms where the number of people varies within a small space, such as supermarkets, shopping centres, hotels, cinemas, hospitals and schools.

12 Index

A

Actual temperature	108
Additional cooling stage.....	84, 108
Additional cooling stage - Control value difference for sending of cooling control value.....	85
Additional cooling stage - Cyclic sending of the control value (min)	85
Additional cooling stage - Hysteresis (x 0.1°C).....	84
Additional cooling stage - Maximum control value (0 - 255).....	85
Additional cooling stage - Minimum control value for basic load (0 - 255).....	86
Additional cooling stage - Mode of the control value.....	84
Additional functions	69
Additional heating stage	76, 107
Additional heating stage - Control value for sending of heating control value	77
Additional heating stage - Cyclic sending of the control value (min)	77
Additional heating stage - Hysteresis (x 0.1°C).....	77
Additional heating stage - Minimum control value for basic load (0 - 255).....	78
Additional heating stage - Mode of control value.....	77
Additional RTC application "Control settings".....	104
Additional RTC communication objects "Control settings".....	120
Adjusting the fan speed levels.....	33
Alarm functions.....	97
Alarm functions — Condensate water alarm.....	97
Alarm functions - Dew point alarm.....	97
Alarm functions - Frost alarm temperature for HVAC and RHCC status (°C).....	97
Alarm functions - Heat alarm temperature for RHCC status (°C).....	98
Alarms	29
Application	103
Application "1-button dimming".....	121
Application "1-button light scene extension unit with memory function".....	125
Application "1-button short-long operation"	127
Application "1-button step switch".....	126
Application "1-button switching"	121
Application "1-button value transmitter, 2 objects"	123
Application "2-button value transmitter".....	122
Application "General functions"	128
Application "RTC"	68
Application for "Button top right".....	121
Application program.....	26, 35
Assigning a physical address	25
Assigning the group address(es).....	25

B

Basic load	112
Basic setpoint	115
Basic stage cooling.....	80, 81
Basic stage cooling - Cyclic sending of the control value (min)	81
Basic stage cooling - Hysteresis (x 0.1°C).....	81

Basic stage cooling - Maximum control value (0 - 255).....	82
Basic stage cooling - Minimum control value for basic load (0 to 255).....	82
Basic stage cooling - Mode of thre control value	80
Basic stage cooling - Status object cooling.....	80
Basic stage heating.....	72
Basic stage heating - Control value difference for sending of heating control value.....	73
Basic stage heating - Cyclic sending of the control value (min)	73
Basic stage heating - Hysteresis (x 0.1°C).....	72
Basic stage heating - Maximum control value (0 - 255).....	74
Basic stage heating - Minimum control value for basic load (0 to 255).....	74
Basic stage heating - Mode of control value	72
Basic stage heating - PWM cycle heating (min)	73
Basic stage heating - Status object heating.....	72
Brightness setting - Brightness of display backlighting	106
Brightness setting - Day/Night mode.....	106

C

Cleaning.....	34
Colling control value.....	107
Combined heating and cooling modes.....	86
Combined heating and cooling modes - Heating/cooling control value output.....	87
Combined heating and cooling modes - Operating mode after reset.....	87
Combined heating and cooling modes - Switchover of heating/cooling	87
Commissioned	120
Commissioning	25
Communication objects - RTC	107
Communication objects – RTC	36
Condensate water alarm.....	116
Confirm fan speed level	119
Confirm setpoint.....	118
Connection, installation / mounting	19
Control elements.....	26
Control function	68
Control of additional cooling stage.....	82
Control of additional cooling stage - Cooling type.....	83
Control of additional cooling stage - Extended settings.....	84
Control of additional cooling stage - P-component (min).....	84
Control of additional cooling stage - P-component (x 0.1°C)	83
Control of additional heating stage	74
Control of additional heating stage - Additional heating type	75
Control of additional heating stage - Control value type	75
Control of additional heating stage - Extended settings.....	76
Control of additional heating stage - P-component (min).....	76
Control of additional heating stage - P-component (x 0.1°C)	76
Control of heating with additional stage - Temperature difference to basic stage (x 0.1°C).....	76
Control On/Off.....	108

Controller status HVAC	120
Controller status RHCC	119
Cooling control.....	78
Cooling control - Control value type	78
Cooling control - Cooling type	79
Cooling control - Extended settings.....	80
Cooling control - I-component (min.)	80
Cooling control - P-component (x 0.1°C).....	79
Cooling status.....	112
Current setpoint.....	110
Cyclic telegram	128
D	
Day/Night mode.....	120
Delay	132
Description of application	35
Description of objects	35
Description of parameters	35
Device function.....	68
Dew point alarm.....	116
Differentiating the application program.....	25
Display backlighting.....	118
Displays	27
E	
E1 – 1-byte value (0 to 255)	37
E1 – 1-byte value (-128 to 127)	37
E1 – 2-byte value (0 to 65,535)	37
E1 – 2-byte value (-32,768 to 32,767)	37
E1 – 4-byte floating point.....	37
E1 – Change temperature, tolerance band 2 lower limit	61
E1 – Change threshold, tolerance band lower limit	38
E1 – Change threshold, tolerance band upper limit	38
E1 – Outside of range.....	38
E1 – Request.....	38
E1 – Send if threshold value undershot.....	39
E1 – Threshold value.....	38
E1-E5 – 1-byte value – (-128 to 127) (event 0)	50
E1-E5 – 1-byte value – (-128 to 127) (event 1)	50
E1-E5 – 2-byte floating point	37
E1-E5 – 2-byte floating point (event 0)	43
E1-E5 – 2-byte floating point (event 1)	43
E1-E5 – 2-byte value – (0 to 255) (event 0)	51
E1-E5 – 2-byte value – (0 to 255) (event 1)	51
E1-E5 – 2-byte value – (0 to 65,535) (event 0)	52
E1-E5 – 2-byte value – (0 to 65,535) (event 1)	52
E1-E5 – 2-byte value – (-32,768 to 32,767) (event 0)	51
E1-E5 – 2-byte value – (-32,768 to 32,767) (event 1)	52
E1-E5 – 4-byte value – (0 to 4,294,967,295) (event 0)	54
E1-E5 – 4-byte value – (0 to 4,294,967,295) (event 1)	54
E1-E5 – 4-byte value – (-2,147,483,648 to 2,147,483,647) (event 0)	53
E1-E5 – 4-byte value – (-2,147,483,648 to 2,147,483,647) (event 1)	53
E1-E5 – Actuating number	40
E1-E5 – Alarm sensor	39
E1-E5 – Blind UP/DOWN	41
E1-E5 – Bottom end position.....	40
E1-E5 – Dimming	40
E1-E5 – Disable.....	45
E1-E5 – Enable save.....	44
E1-E5 – IC – Counter reading 1-byte value	57
E1-E5 – IC – Counter reading 2-byte value	58
E1-E5 – IC – Counter reading 4-byte value	58
E1-E5 – IC – Limit value exceeded.....	56
E1-E5 – IC – Request counter reading	58
E1-E5 – IC – Reset.....	57
E1-E5 – IC – Reverse direction	57
E1-E5 – IC – Stop	56
E1-E5 – MC – Counter reading 1-byte value	55
E1-E5 – MC – Counter reading 2-byte value	55
E1-E5 – MC – Counter reading 4-byte value	56
E1-E5 – MC – Limit value exceeded.....	55
E1-E5 – MC – Request counter reading	54
E1-E5 – Priority (event 0).....	42
E1-E5 – Priority (event 1).....	42
E1-E5 – Save scene	47
E1-E5 – Scene.....	46
E1-E5 – Scene (event 0).....	46
E1-E5 – Scene (event 1).....	46
E1-E5 – Scene storage display.....	39
E1-E5 – Start event 0/1.....	41
E1-E5 – STOP/slat adjustment	42
E1-E5 – Switch (event 0)	43
E1-E5 – Switch (event 1)	44
E1-E5 – Switch step up/down	46
E1-E5 – Switching.....	47
E1-E5 – Switching – 1 actuation	47
E1-E5 – Switching – 2 actuations	48
E1-E5 – Switching – 3 actuations	48
E1-E5 – Switching – 4 actuations	48
E1-E5 – Switching – long actuation	48
E1-E5 – Switching – step 1	49
E1-E5 – Switching – step 2	49
E1-E5 – Switching – step 3.....	49
E1-E5 – Switching – step 4	49
E1-E5 – Switching – step 5.....	50
E1-E5 – Switching sensor.....	44
E1-E5 – Top end position	41
E4 – 2-byte threshold value 1	59
E4 – 2-byte threshold value 2	59
E4 – Bit threshold value 1	59
E4 – Bit threshold value 2	59
E4 – Byte threshold value 1	60
E4 – Byte threshold value 2	60
E4 – Change threshold, tolerance band 2 upper limit.....	61
E4 – Change threshold, tolerance band lower limit.....	60
E4 – Change threshold, tolerance band upper limit.....	60
E4 – Heating temperature limit	62
E4 – Measured value outside of range	60
E4 – Output value	59
E4 – Request output value.....	59
E4 – Send if threshold value 1 exceeded	61
E4 – Send if threshold value 1 undershot.....	61
E4 – Temperature threshold value 1.....	62
E4 – Temperature threshold value 2.....	62
Eco mode.....	31
Electrical connection	23, 24
Environment.....	15
Extended settings - Colour scheme of display backlighting	106

External actual temperature	109	Heating/cooling request	119
External actual temperature 2	109	I	
F		Improper use	12
Fahrenheit	117	Information about planning and application	135
Fan coil manual	113	Information and symbols used	11
Fan coil settings - Fan speed levels	98	Information on protection of the environment	15
Fan coil settings - Fan speed levels - Format of the level output	98	Installation site	20
Fan coil settings - Fan speed levels - Level output	99	Intended use	12
Fan coil settings - Fan speed levels - Level status evaluation	99	K	
Fan coil settings - Fan speed levels - Lowest manually adjustable level	99	KNX room climate control	135
Fan coil settings - Fan speed levels - Number of fan speed levels	98	L	
Fan coil settings for cooling	100	Light scene actuator	134
Fan coil settings for cooling - Fan speed level limit cooling for eco mode	101	Local actual temperature	109
Fan coil settings for heating - Fan speed level limit heating for eco mode	100	Logic	130
Fan coil settings for heating - Maximum speed level heating for eco mode	100	M	
Fan coil settings heating	99	Maintenance	34
Fan coil settings heating - Fan speed level 1 to 5 up to control value (0 to 255) heating	100	MC – Main counter reading	36
Fan coil step status	114	Messages	27
Fan speed level 1	114	Min/Max value transducer	133
Fan speed level 2	114	Mounting	22
Fan speed level 3	115	N	
Fan speed level 4	115	Notes on the instruction manual	10
Fan speed level 5	115	O	
Fan speed level for cooling - Fan speed level 1 to 5 up to control value (0 to 255) cooling	101	On/off request	118
Fan speed settings for cooling - Maximum fan speed level cooling for eco mode	101	Operating mode	110
Fancoil step	114	Operating modes	29
Fault, actual temperature	109	Operating status	33
Functions	16	Operation	13, 26
G		Outside temperature for summer compensation	116
Gate	131	P	
General - Display of actual temperature	105	P – Air pressure sensor error	62
General - Display of actual temperature in eco mode	105	P – Request relative air pressure	62
General – Jump-back to the primary function	104	Possible combinations	16
General - Operating mode after reset	69	Presence detector	112
General - Setpoint display	105	Priority	129
General - Setting the temperature unit via object	105	Q	
General - Waiting period for display of actual temperature	105	Qualification of personnel	13
Good air	135	R	
H		Request fan speed level	119
Heating / cooling	33	Request fan speed level manually	119
Heating control	70	Request setpoint	118
Heating control - Control value type	70	Request status	36
Heating control - Extended settings	72	Resetting manual setpoints	115
Heating control - Heating type	71	RFR – Basic set value (1 byte) [%]	63
Heating control - I-component (min.)	71	RFR – Basic set value [%]	63
Heating control - P-component (x 0.1°C)	71	RFR – Blocking object	63
Heating control value	107	RFR – Blocking object threshold 1	63
Heating status	112	RFR – Blocking object threshold 2	63
		RFR – Blocking object threshold 3	64
		RFR – Control value (0 to 100%)	64
		RFR – Control value (0 to 255)	64
		RFR – Control value step 1 (priority)	64
		RFR – Control value step 1 (switch object)	64

RFR – Control value step 2 (priority)	65
RFR – Control value step 2 (switch object)	65
RFR – Control value step 3 (priority)	65
RFR – Control value step 3 (switch object)	65
RFR – Scene (1 to 64)	65
rH – External humidity value [%]	67
rH – Humidity value [%]	67
rH – Request humidity value	67
rH – Sensor error	67
Room air quality	135
S	
Safety	11
Safety instructions	14
Selecting the application program	25
Send	36
Send cyclic "In operation" (min)	70
Setpoint adjustment	92
Setpoint adjustment - Maximum manual increase during cooling mode (0 - 15°C)	92
Setpoint adjustment - Maximum manual increase during heating mode (0 - 15°C)	92
Setpoint adjustment - Maximum manual reduction during cooling mode (0 - 15°C)	93
Setpoint adjustment - Maximum manual reduction during heating mode (0 - 15°C)	92
Setpoint adjustment - Permanent storage of on-site operation	94
Setpoint adjustment - Resetting of the manual adjustment for receipt of a basic setpoint	93
Setpoint adjustment - Resetting the manual adjustment for change of operating mode	93
Setpoint adjustment - Resetting the manual adjustment via object	93
Setpoint display	118
Setpoint reached	117
Setpoint settings	88
Setpoint settings - Cyclic sending of the current set-point temperature (min)	92
Setpoint settings - Display indicates	91
Setpoint settings - Hysteresis for switchover heating/cooling	89
Setpoint settings - Increase for ECO cooling (°C)	90
Setpoint settings - Increase for standby cooling (°C)	90
Setpoint settings - Reduction for ECO heating (°C)	90
Setpoint settings - Reduction for standby heating (°C)	89
Setpoint settings - Send current setpoint	91
Setpoint settings - Setpoint for heating comfort = setpoint for cooling comfort	88
Setpoint settings - Setpoint temperature for cooling comfort (°C)	90
Setpoint settings - Set-point temperature for frost protection (°C)	90
Setpoint settings - Set-point temperature for heat protection (°C)	91
Setpoint settings - Setpoint temperature for heating and cooling comfort (°C)	89
Setpoint settings - Setpoint temperature for heating comfort (°C)	89
Setting functions	30
Setting operating modes	30
Setting the required temperature	30
Setting the setpoint temperature	30
Settings of basic load	86
Settings of basic load - Minimum control value for basic load > 0	86
Setup and function	16
Sources of interference	16
Staircase lighting	131
Summer compensation	101
Summer compensation - (Lower) Starting temperature for summer compensation (°C)	102
Summer compensation - Offset of the set-point temperature for the entry into summer compensation (x 0.1°C)	103
Summer compensation - Offset of the set-point temperature for the exit from summer compensation (x 0.1°C)	104
Summer compensation - Summer compensation	101
Summer compensation active	117
Superimposed operating mode	111
Switching On and Off	32
Switchover heating/cooling	113
T	
T – External temperature value [°C]	67
T – Frost alarm	66
T – Heat alarm	66
T – Request temperature value	66
T – Sensor error	66
T – Temperature value [°C]	66
Target group	13
Technical data	17
Temperature display – Temperature unit	104
Temperature reading - Adjustment value for internal temperature measurement (x 0.1°C)	96
Temperature reading - Control value for fault (0 - 255)	96
Temperature reading - Cyclic sending of actual temperature (min)	95
Temperature reading - Difference of value for sending the actual temperature (x 0.1°C)	95
Temperature reading - Inputs of temperature reading	94
Temperature reading - Inputs of weighted temperature reading	94
Temperature reading - Monitoring time for temperature reading (0 = no monitoring) (min)	96
Temperature reading - Operating mode for fault	96
Temperature reading - Weighting of external measurement (0 to 100%)	95
Temperature reading - Weighting of external measurement 2 (0 to 100%)	95
Temperature reading - Weighting of internal measurement (0 to 100%)	94
Threshold value / hysteresis	134
W	
Window contact	111

A member of the ABB Group

Busch-Jaeger Elektro GmbH
PO box
58505 Lüdenscheid

Freisenbergstraße 2
58513 Lüdenscheid

www.BUSCH-JAEGER.com
info.bje@de.abb.com

Central sales service:
Tel.: +49 2351 956-1600
Fax: +49 2351 956-1700

Notice

We reserve the right to make technical changes at all times as well as changes to the contents of this document without prior notice. The detailed specifications agreed upon apply for orders. ABB accepts no responsibility for possible errors or incompleteness in this document.

We reserve all rights to this document and the topics and illustrations contained therein. The document and its contents, or extracts thereof, must not be reproduced, transmitted or reused by third parties without prior written consent by ABB

Copyright© 2016 Busch-Jaeger
Elektro GmbH
All rights reserved