

KNX Technical Reference Manual

Busch-priOn®

Busch-priOn®



innovative and intuitive

Improved control elements. For example, the new 8.9 cm (3.5") TFT display as informative component of a flush-type combination is both stylish and efficient. Its menu can be individually adapted to every building and at all times provides an overview of the electrical consumers. From here the heating can be controlled, the lights dimmed or comprehensive scenes called up that trigger numerous preprogrammed actions. Meaningful symbols lead even the untrained user to his objective in just a few steps. The division of functions into individual areas such as light, heating or blinds, assists everyone to find his way around intuitively. Yet, this is not the end of possibilities for the **Busch-priOn®** in classical building technology. The display can also be used for controlling music.

The combination of pushbutton/rotary control element and display has a universal operating concept. The definition of a primary function makes its use particularly easy. The primary function appears when one approaches the display (a special proximity sensor is available) or when pressing the rotary control element. In principle, any switching, dimming, blinds, scene or sequence function that has been stored in the unit can be defined as primary function. It is only when the menu button is pressed that the display changes to the circuit menu. Up to 8 entries can be displayed via one symbol. By turning the pushbutton/rotary control element the user can bring the desired function into the foreground. An associated text below the focused symbol is shown (e.g. system settings, room control office, room control, living room, etc.). By activating the pushbutton/rotary control element the display changes to the respective list menu, which can consist of up to 15 different functions. The user can scroll through these functions by turning the pushbutton/rotary control element. The function is selected by pressing the button.

KNX Technical Reference Manual

Busch-priOn®

1	Safety instructions.....	9
2	Dimensional drawings.....	10
3	Frame-free variety.....	11
4	Combinations as desired	12
5	Not just any KNX control element	13
6	The right bus coupler	15
7	Easy to mount	16
8	Room temperature controller operation	17
8.1	Room thermostat with display	17
8.1.1	Standard view	17
8.1.2	Set values	17
8.2	Operating modes.....	18
9	Room temperature controller operation (only 6351/08-825-500 + 6344-101-500 [from update version 0.1.6.0])..	19
9.1	Busch-priOn 8.89 cm display 6344-xxx-101-500	19
9.1.1	Operating process.....	19
9.1.2	Operating functions.....	20
9.1.3	Info line	21
9.1.4	Busch-priOn® top end strip with display 6351/08-825-500	21
9.2	Combination with 3gang control element 6342-xxx-101-500	22
9.2.1	Operating process.....	22
9.3	Combination with 1gang rotary control element 6341-xxx-101-500	23
9.3.1	Operating process.....	23
9.3.2	Operating modes.....	24
10	Planner support for RTC	25
10.1	Operating modes.....	25
10.1.1	Operating mode switchover, 1 bit.....	25
10.1.2	Operating mode switchover, 1 byte.....	26
10.1.3	Monitoring	27
10.1.4	External temperature sensor.....	27
10.1.5	Adjustment.....	28
10.2	Controller	28
10.2.1	2-point controller	29
10.2.2	Continuous controller	29
10.2.3	PWM controller	30
10.2.4	Fan coil	30
10.2.5	Control parameter for PWM controller and continuous controller (Fan coil).....	30
10.2.6	Two-stage heating / cooling	31
10.3	Set values	31
10.3.1	Dependent setpoints	31
10.3.2	Individual setpoints.....	32
10.3.3	Minimum distance	32
10.4	Fan coil, general	33
10.5	Compensation.....	34
10.5.1	Summer compensation	34
10.5.2	Winter compensation	35
11	Description of application	36
11.1	Switching, rocker total	36
11.2	Switching, rocker left/right	36
11.3	Dimming, rocker total	36
11.4	Dimming, rocker left/right	37
11.5	Blind, rocker total	37

11.6	Blind, rocker left/right	37
11.7	Value sender, rocker total	38
11.8	Value sender, rocker left/right	38
11.9	Value sender, 2 objects, rocker left/right	39
11.10	Value dimming sensor, rocker total	39
11.11	Light scene extension unit with memory function	40
11.12	Step switch, rocker total	40
11.13	Step switch, rocker left/right	41
11.14	Multiple operation, rocker left/right	41
11.15	Short/long operation, rocker left/right	43
11.16	Setting RTC operation mode.....	43
11.17	Media control, CD player.....	44
11.18	Media control, radio.....	45
11.19	Media control, video player	46
11.20	Short-time timer.....	46
11.21	Weekly timer	47
11.22	Alarm clock	48
11.23	Messages.....	49
11.24	Title text	49
11.25	Unit blockage	50
11.26	RTC settings	50
11.27	Sequence actuator settings.....	50
11.28	Shutting actuator.....	51
11.29	Switch actuator application	51
11.30	Movement detector	52
11.31	LED function	54
11.32	Alarm function	54
11.33	Light scene memory function	54
11.34	Delay.....	55
11.35	Staircase lighting.....	56
11.36	Light scene actuator.....	57
11.37	Sequence.....	57
11.38	Preset.....	58
11.39	Cyclic telegram.....	58
11.40	Flashing	59
11.41	Logic	59
11.42	Gate	60
11.43	Min/Max value transducer	61
11.44	Threshold value / hysteresis	62
11.45	PWM inverter	62
11.46	Priority.....	63
12	Description of applications/parameters for room temperature control 6351/08-825 + 6344-101 [from update version 0.1.6.0	64
12.1	Application "RTC".....	64
12.1.1	General - Device function.....	64
12.1.2	General - Control function	64
12.1.3	General - Operating mode after reset	65
12.1.4	General - Additional functions	65
12.1.5	General - Send cyclic "In operation" (min)	66
12.1.6	Heating control	66
12.1.7	Heating control - Control value type	66
12.1.8	Heating control - Heating type.....	67

12.1.9	Heating control - P-component (x 0.1°C)	67
12.1.10	Heating control - I-component (min.)	68
12.1.11	Heating control - Extended settings	68
12.1.12	Basic stage heating	68
12.1.13	Basic stage heating - Status object heating	68
12.1.14	Basic stage heating - Mode of the control value	68
12.1.15	Basic stage heating - Hysteresis (x 0.1°C)	69
12.1.16	Basic stage heating - Control value difference for sending of heating control value	69
12.1.17	Basic stage heating - Cyclic sending of the control value (min)	69
12.1.18	Basic stage heating - PWM cycle heating (min)	70
12.1.19	Basic stage heating - Maximum control value (0 - 255)	70
12.1.20	Basic stage heating - Minimum control value for basic load (0 to 255)	70
12.1.21	Control of additional heating stage	70
12.1.22	Control of additional heating stage - Control value type	71
12.1.23	Control of additional heating stage - Additional heating type	72
12.1.24	Control of additional heating stage - P-component (x 0.1°C)	72
12.1.25	Control of additional heating stage - P-component (min)	73
12.1.26	Control of additional heating stage - Temperature difference to basic stage (x 0.1°C)	73
12.1.27	Control of additional heating stage - Extended settings	73
12.1.28	Additional heating stage	73
12.1.29	Additional heating stage - Mode of the control value	73
12.1.30	Additional heating stage - Hysteresis (x 0.1°C)	74
12.1.31	Additional heating stage - Control value difference for sending of heating control value	74
12.1.32	Additional heating stage - Cyclic sending of the control value (min)	75
12.1.33	Additional heating stage - Minimum control value for basic load (0 - 255)	75
12.1.34	Cooling control	76
12.1.35	Cooling control - Control value type	76
12.1.36	Cooling control - Cooling type	77
12.1.37	Cooling control - P-component (x 0.1°C)	77
12.1.38	Cooling control - I-component (min.)	77
12.1.39	Cooling control - Extended settings	78
12.1.40	Basic stage cooling	78
12.1.41	Basic stage cooling - Status object cooling	78
12.1.42	Basic stage cooling - Mode of the control value	78
12.1.43	Basic stage cooling - Hysteresis (x 0.1°C)	79
12.1.44	Basic stage cooling - Cyclic sending of the control value (min)	79
12.1.45	Basic stage cooling	80
12.1.46	Basic stage cooling - Maximum control value (0 - 255)	80
12.1.47	Basic stage cooling - Minimum control value for basic load (0 to 255)	80
12.1.48	Control of additional cooling stage	81
12.1.49	Control of additional cooling stage - Cooling type	82
12.1.50	Control of additional cooling stage - P-component (x 0.1°C)	82
12.1.51	Control of additional cooling stage - P-component (min)	82
12.1.52	Control of additional cooling stage - Extended settings	83
12.1.53	Additional cooling stage	83
12.1.54	Additional cooling stage - Mode of the control value	83
12.1.55	Additional cooling stage - Hysteresis (x 0.1°C)	83
12.1.56	Additional cooling stage - Control value difference for sending of cooling control value	84
12.1.57	Additional cooling stage - Cyclic sending of the control value (min)	84
12.1.58	Additional cooling stage - Maximum control value (0 - 255)	84
12.1.59	Additional cooling stage - Minimum control value for basic load (0 - 255)	85
12.1.60	Settings of basic load	85

12.1.61	Settings of basic load - Minimum control value for basic load > 0	85
12.1.62	Combined heating and cooling modes	85
12.1.63	Combined heating and cooling modes - Switchover of heating/cooling	86
12.1.64	Combined heating and cooling modes - Operating mode after reset	86
12.1.65	Combined heating and cooling modes - Heating/cooling control value output	86
12.1.66	Combined heating and cooling modes - Additional heating/cooling stage control value output	87
12.1.67	Setpoint settings.....	87
12.1.68	Setpoint settings - Setpoint for heating comfort = setpoint for cooling comfort.....	87
12.1.69	Setpoint settings - Hysteresis for switchover heating/cooling (x 0.1°C).....	88
12.1.70	Setpoint settings - Setpoint temperature for heating and cooling comfort (°C).....	88
12.1.71	Setpoint settings - Setpoint temperature for heating comfort (°C).....	88
12.1.72	Setpoint settings - Reduction for standby heating (°C).....	88
12.1.73	Setpoint settings - Reduction for ECO heating (°C)	89
12.1.74	Setpoint settings - Set-point temperature for frost protection (°C).....	89
12.1.75	Setpoint settings - Setpoint temperature for cooling comfort (°C)	89
12.1.76	Setpoint settings - Increase for standby cooling (°C)	89
12.1.77	Setpoint settings - Increase for ECO cooling (°C)	90
12.1.78	Setpoint settings - Set-point temperature for heat protection (°C).....	90
12.1.79	Setpoint settings - Display indicates.....	90
12.1.80	Setpoint settings - Display indicates.....	90
12.1.81	Setpoint settings - Send current setpoint	91
12.1.82	Setpoint settings - Cyclic sending of the current set-point temperature (min)	91
12.1.83	Setpoint adjustment	91
12.1.84	Setpoint adjustment — Maximum manual increase during heating mode (0 - 15°C)	91
12.1.85	Setpoint adjustment — Maximum manual reduction during heating mode (0 - 15°C).....	91
12.1.86	Setpoint adjustment — Maximum manual increase during cooling mode (0 - 15°C).....	92
12.1.87	Setpoint adjustment — Maximum manual reduction during cooling mode (0 - 15°C)	92
12.1.88	Setpoint adjustment - Resetting of the manual adjustment for receipt of a basic setpoint	92
12.1.89	Setpoint adjustment - Resetting the manual adjustment for change of operating mode	93
12.1.90	Setpoint adjustment - Resetting the manual adjustment via object.....	93
12.1.91	Setpoint adjustment - Permanent storage of on-site operation	93
12.1.92	Temperature reading - Inputs of temperature reading.....	93
12.1.93	Temperature reading - Inputs of weighted temperature reading	94
12.1.94	Temperature reading - Weighting of internal measurement (0 to 100%).....	94
12.1.95	Temperature reading - Weighting of external measurement (0 to 100%).....	94
12.1.96	Temperature reading - Weighting of external measurement 2 (0 to 100%).....	94
12.1.97	Temperature reading - Cyclic sending of the actual temperature (min).....	95
12.1.98	Temperature reading - Difference of value for sending the actual temperature (x 0.1°C)	95
12.1.99	Temperature reading - Adjustment value for internal temperature measurement (x 0.1°C)	95
12.1.100	Temperature reading - Monitoring time for temperature reading (0 = no monitoring) (min).....	95
12.1.101	Temperature reading — Operating mode for fault.....	96
12.1.102	Temperature reading - Control value for fault (0 - 255).....	96
12.1.103	Alarm functions	96
12.1.104	Alarm functions - Condensate water alarm	96
12.1.105	Alarm functions — Dew point alarm	97
12.1.106	Alarm functions - Frost alarm temperature for HVAC and RHCC status (°C).....	97
12.1.107	Alarm functions - Heat alarm temperature for RHCC status (°C)	97
12.1.108	Fan coil settings - Fan speed levels	97
12.1.109	Fan coil settings - Fan speed levels Number of fan speed levels	97
12.1.110	Fan coil settings - Fan speed levels - Format of the level output	98
12.1.111	Fan coil settings - Fan speed levels - Level output	98
12.1.112	Fan coil settings - Fan speed levels - Lowest manually adjustable level.....	98

12.1.113	Fan coil settings - Fan speed levels - Level status evaluation	99
12.1.114	Fan coil settings heating	99
12.1.115	Fan coil settings for heating - Speed level 1 to 5 up to control value (0 to 255) heating	99
12.1.116	Fan coil settings for heating - Fan speed level limit heating for eco mode	99
12.1.117	Fan coil settings for heating - Maximum speed level heating for eco mode	100
12.1.118	Fan coil settings for cooling	100
12.1.119	Fan coil settings for cooling - Speed level 1 to 5 up to control value (0 to 255) cooling	100
12.1.120	Fan coil settings for cooling - Fan speed level limit cooling for eco mode	100
12.1.121	Fan coil settings for cooling - Maximum fan speed level cooling for eco mode	100
12.1.122	Summer compensation	101
12.1.123	Summer compensation - Summer compensation	101
12.1.124	Summer compensation - (Lower) Starting temperature for summer compensation (°C)	102
12.1.125	Summer compensation - Offset of the set-point temperature for the entry into summer compensation (x 0.1°C)	102
12.1.126	Summer compensation - (Upper) exit temperature for summer compensation (°C)	102
12.1.127	Summer compensation - Offset of the set-point temperature for the exit from summer compensation (x 0.1°C)	103
12.2	Communication objects - RTC	104
12.2.1	Heating control value	104
12.2.2	Additional heating stage	104
12.2.3	Cooling control value	104
12.2.4	Additional cooling stage	105
12.2.5	Control On/Off	105
12.2.6	Actual temperature	106
12.2.7	External actual temperature	106
12.2.8	External actual temperature 2	106
12.2.9	Fault, actual temperature	107
12.2.10	Local actual temperature	107
12.2.11	Current setpoint	108
12.2.12	Operating mode	108
12.2.13	Superimposed operating mode	109
12.2.14	Window contact	109
12.2.15	Presence detector	110
12.2.16	Heating status	110
12.2.17	Cooling status	110
12.2.18	Basic load	111
12.2.19	Switchover heating/cooling	111
12.2.20	Fan coil manual	112
12.2.21	Fan coil step	112
12.2.22	Fan coil step status	113
12.2.23	Fan speed level 1	113
12.2.24	Fan speed level 2	113
12.2.25	Fan speed level 3	113
12.2.26	Fan speed level 4	113
12.2.27	Fan speed level 5	114
12.2.28	Basic setpoint	114
12.2.29	Resetting manual setpoints	114
12.2.30	Dew point alarm	114
12.2.31	Condensate water alarm	115
12.2.32	Outside temperature for summer compensation	115
12.2.33	Summer compensation active	116
12.2.34	Setpoint reached	116

12.2.35	Fahrenheit.....	116
12.2.36	Display backlighting	117
12.2.37	On/Off request.....	117
12.2.38	Setpoint display.....	117
12.2.39	Request setpoint	117
12.2.40	Confirm setpoint.....	117
12.2.41	Heating/cooling request	118
12.2.42	Request fan speed level manual.....	118
12.2.43	Request fan speed level.....	118
12.2.44	Confirm fan speed level	118
12.2.45	Controller status RHCC.....	119
12.2.46	Controller status HVAC	119
12.2.47	Commissioned	119

KNX Technical Reference Manual

Busch-priOn®

1 Safety instructions



Work on the 230 V power supply system must only be performed by specialist staff. Disconnect the mains power supply prior to mounting and/or disassembly! Failure to observe the installation and operating instructions may result in fire or other hazards.



Disclaimer

The content of this printed material has been checked for compliance with hardware and software. However, no liability can be assumed for any deviations that may still occur. Any necessary corrections will be implemented in future versions of this manual. Please advise us of any suggestions concerning the manual's improvement you may have.

2 Dimensional drawings

Flush-type 8,9 cm (3,5") display with control element, Busch-priOn®

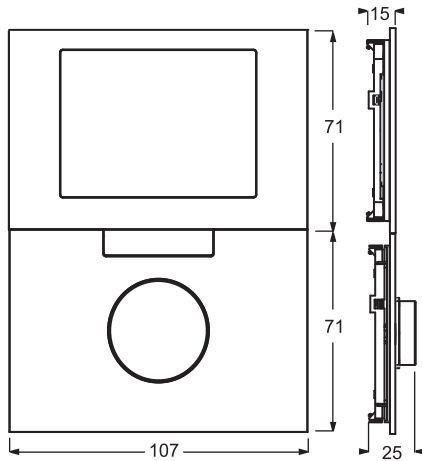

Support frame for Busch-priOn® 6346/12-101-500

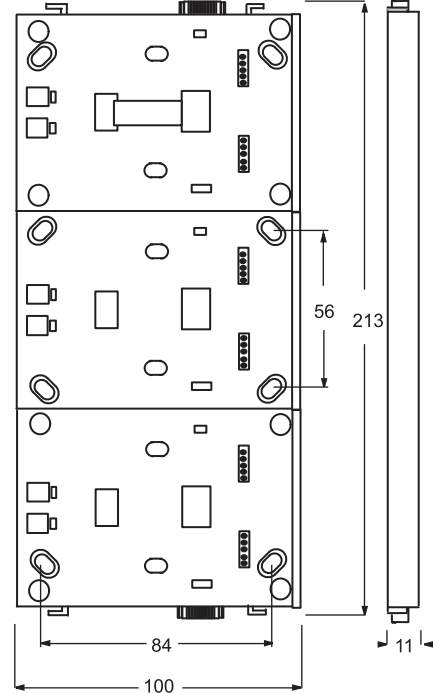

Flush-type control element, Busch-priOn® 6340-xxx-101-500

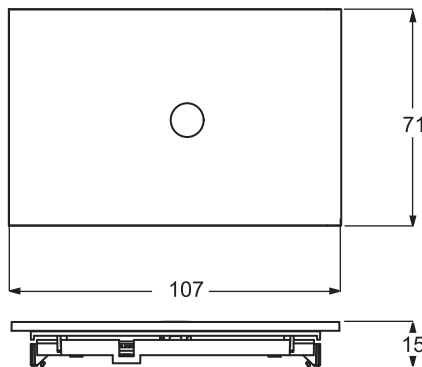

Flush-type rotary control element, 6341-xxx-101-500

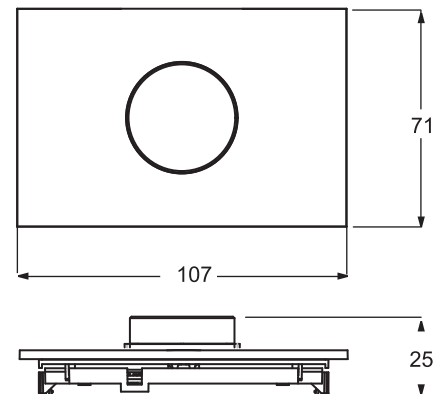

Flush-type movement detector Busch-priOn® 6345-xxx-101-500

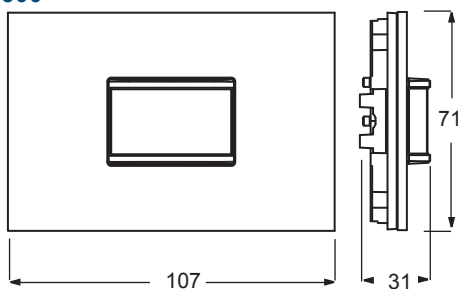

3 Frame-free variety

It is not merely individuality which characterises **Busch-priOn®** during programming of the individual buttons: Also the assembly arrangement of the **Busch-priOn®** combinations are highly flexible. For Busch-priOn is not bound to frames -- instead, up to 3 individual elements are fixed to a support frame and, at the end, provided with end strips above and below. There are four choices of finish for the control elements: studio white, glass white, glass black and stainless steel. Most of the end strips are also available in these colour versions. For the display (style sheets), there are three choices: black, blue and silver.

Modular design

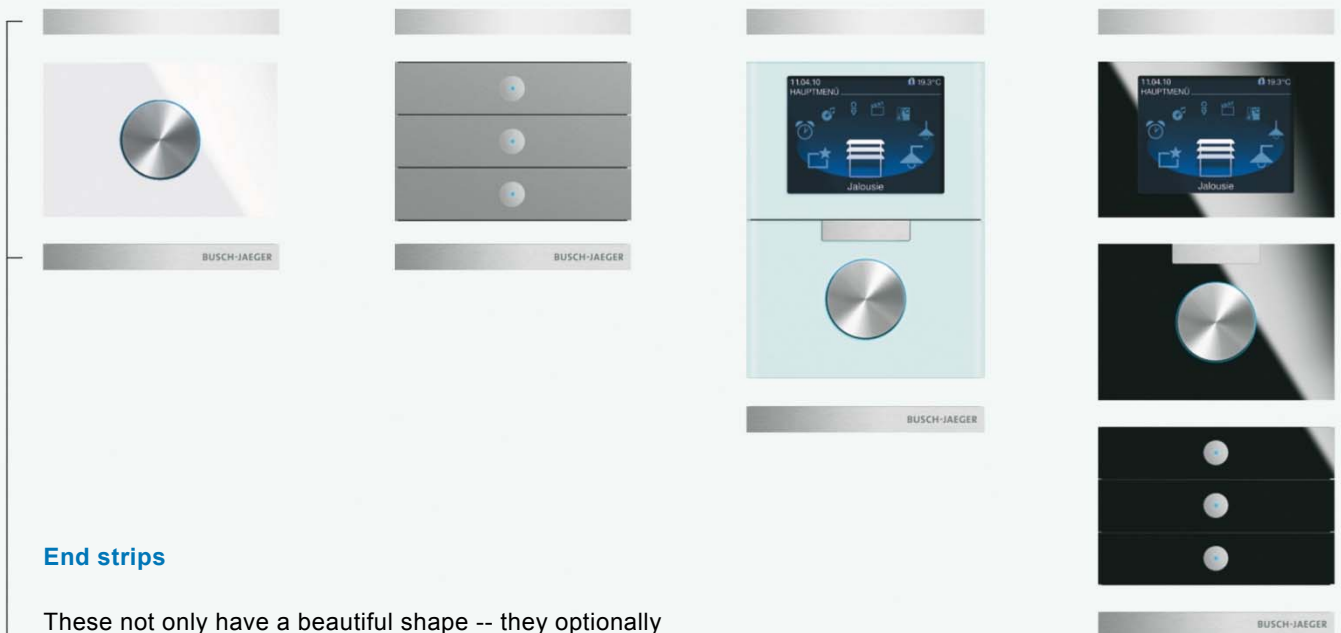

End strips

These not only have a beautiful shape -- they optionally contain a temperature sensor for room temperature control, an infrared interface for the remote control and a proximity sensor for activating the display or LED of the control elements when somebody approaches. This IR / proximity sensor version is only available in glass black and not in the other colours. Additional information about controlling the room temperature with Busch-priOn® is contained in the brochure on heating, ventilation and air conditioning.

4 Combinations as desired

The control elements and end strips can be freely combined in their colours and functions for **Busch-priOn**. Up to 3gang combinations are possible, whereby a single bus coupler will suffice.

	Article number	Support frame		
		1gang	2gang	3gang
Top end strip IR / proximity sensor	6350-825-101-500	•	•	•
Top end strip with display, IR / proximity sensor	6351-825-101-500	•	•	•
Top end strip standard	6348-101-500	•	•	•
Top end strip with display, IR / proximity sensor	6351/08-825-500	•	•	•
1gang control element	6340-101-500	•	•	•
3gang control element	6342-101-500	•	•	•
1gang rotary control element	6341-101-500	•	•	•
Movement detector	6345-101-500	•	•	•
8.9 cm display including control element	6344-101-500	-	•	•
Bottom end strip, temperature	6352-101-500	•	•	•
Bottom end strip standard	6349-101-500	•	•	•
Bus coupler	6120/12-500	•	-	-
Power bus coupler and power adaptor, MDRC	6120/13-500 + 6358-500	•	•	•
Network coupler	6920/12	•	-	-
Power mains coupler	6920/13	•	•	•
Flush-mounted switch actuator	6354-500	-	•	•
Flush-mounted dimming actuator, 1gang	6355-500	-	•	•
Flush-mounted blind / switch actuator	6356-500	-	•	•
Flush-mounted blind / switch actuator	6920/40	•	•	-

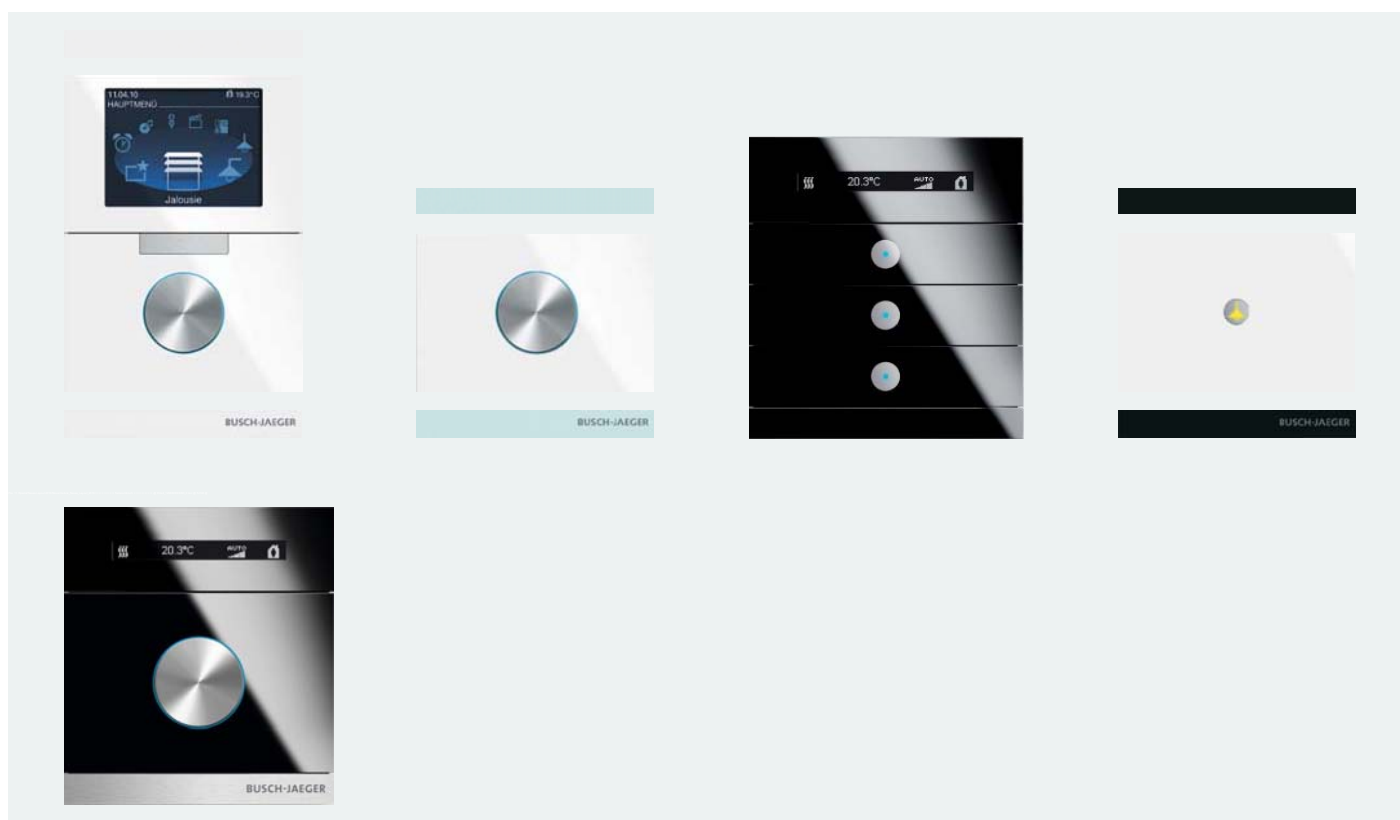

5 Not just any KNX control element

Each of the buttons of the Busch-*priOn*® can be programmed individually, as is usually the case with KNX. The applications range from switching, dimming and blinds on through to scenes. Logic functions are also possible. The use of the display makes additional functions available. Weekly timers, messages and multimedia applications can be integrated here, for example. Also additional applications can be implemented with the assigning of internal group addresses. The user menu can be configured in 19 languages.

Applications

Application	Control element	Rotary control element	8.9 cm (3,5") TFT display with control element	Movement detector	Page number
Switching, rocker total	•	-	-	-	Page 36
Switching, rocker left/right	•	-	•	-	Page 36
Dimming, rocker total	•	-	-	-	Page 36
Dimming, rocker left/right	•	•	•	-	Page 37
Blind, rocker total	•	-	-	-	Page 37
Blind, rocker left/right	•	•	•	-	Page 37
Value sender, rocker total	•	-	-	-	Page 38
Value sender, rocker left/right	•	•	•	-	Page 38
Value sender, 2 objects, rocker left/right	•	-	-	-	Page 39
Value dimming sensor, rocker total	•	-	•	-	Page 39
Light scene extension unit with memory function	•	-	•	-	Page 40
Level switch, rocker total	•	-	-	-	Page 40
Level switch, rocker left/right	•	-	-	-	Page 41
Multiple actuation, rocker left/right	•	-	-	-	Page 41
Short/long operation, rocker left/right	•	-	-	-	Page 43
Setting RTC operation mode	•	-	•	-	Page 43
Media control, CD player	-	-	•	-	Page 44
Media control, radio	-	-	•	-	Page 45
Media control, video player	-	-	•	-	Page 46
Short-time timer	-	-	•	-	Page 46
Weekly timer	-	-	•	-	Page 47
Alarm clock	-	-	•	-	Page 48
Messages	-	-	•	-	Page 49
Title text	-	-	•	-	Page 49
Unit blockage	-	-	•	-	Page 50
RTC settings	-	-	• ¹	-	Page 50
Sequence actuator settings	-	-	•	-	Page 50
Venetian blind application	•	•	• ²	-	Page 51
Switch actuator application	•	•	•	-	Page 51
Movement detector	-	-	-	•	Page 52
LED functionality	•	•	•	-	Page 54
Alarm function	•	•	-	-	Page 54
Storage function Light scenes	•	•	•	-	Page 54

1 Only in connection with a bottom end strip "temperature sensor" or another external sensor. Busch-*priOn*® has 1 internal room thermostat.

2 Only in connection with flush-type blind / 2-gang actuator 6356.

General functions

Function	Large-area control element	Rotary control element	8.9 cm (3,5") TFT display with control element	Movement detector	Page number
Delay	•	•	•	•	Page 55
Staircase lighting	•	•	•	•	Page 56
Light scene actuator settings	•	•	•	•	Page 57
Sequence	•	•	•	•	Page 57
Preset	•	•	•	•	Page 58
Cyclic telegram	•	•	•	•	Page 58
Flashing	•	•	•	•	Page 59
Logic	•	•	•	•	Page 59
Gate	•	•	•	•	Page 60
Min/Max value transducer	•	•	•	•	Page 61
Threshold value / hysteresis	•	•	•	•	Page 62
PWM inverter	•	•	•	•	Page 62
Priority	•	•	•	•	Page 62



Busch-priOn®
2gang combination,
glass black



Busch-priOn®
Rotary control element
glass black

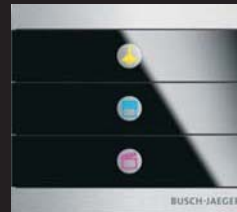

Busch-priOn®
3gang control element,
glass black



Busch-priOn®
1gang control element,
glass black



Busch-priOn®
Top end strip
+ 3gang control element,
glass black



Busch-priOn®
Top end strip
Rotary control element
glass black



Busch-priOn® Watchdog 180 flush-mounted,
glass black



Busch-priOn® is ideally combinable with the **carat®** switch range. These switches distinguish themselves through their uniformly designed surfaces.

6 The right bus coupler

Maximum number of Busch-priOn® devices per TP line

Number of display combinations per line	Total number of combinations ¹	Total number of TP-Power bus couplers 6120/13 per line
0	0 + 60	60
1	1 + 59	60
2	2 + 58	60
3	3 + 57	60
4	4 + 56	60
5	5 + 55	60
6	6 + 54	60
7	7 + 53	60
8	8 + 52	60
9	9 + 51	60
10	10 + 45	55
11	11 + 37	48
12	12 + 30	42
13	13 + 22	35
14	14 + 15	29
15	15 + 7	22
16	16 + 0	16

¹ Composed of display combinations plus 1- to 3-gang combinations without display with end strips

Only one bus coupler is mounted behind every Busch-priOn® combination. One standard bus coupler is adequate for one 1-gang support frame. With the use of the 2-gang carrier frame the more powerful power bus coupler must be used.

The twisted pair version requires an external power pack for this purpose. The table to the left describes the corresponding device combinations.

Standard bus coupler, TP

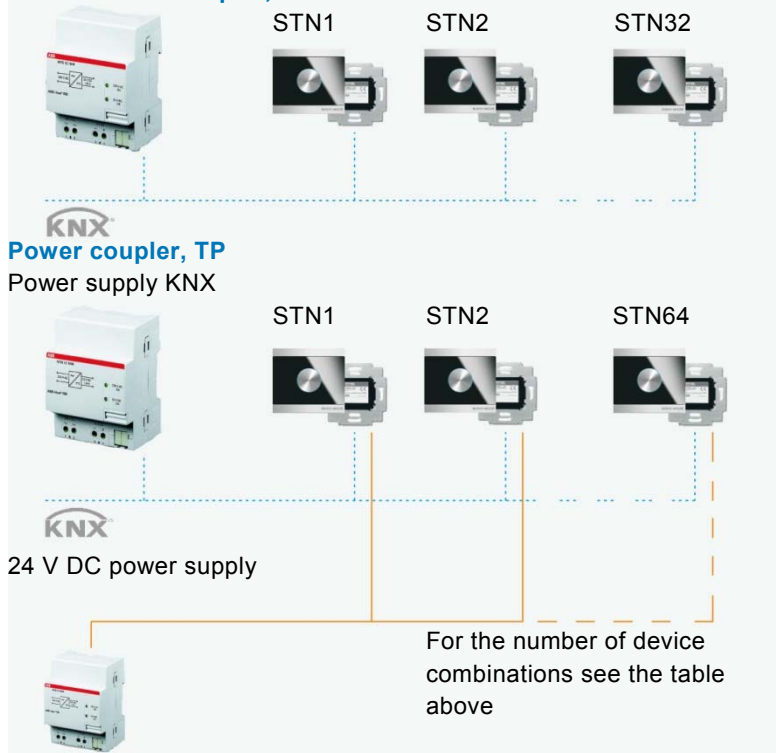

7 Easy to mount

The carrier frame serves to hold and make contact with the individual control elements, the 8.9 cm (3,5") TFT display, the end strips and the flush-type bus coupler. The position of the control elements can be selected freely for multiple combinations. A special strip must be mounted on top as well as below. Its material can be different to that of the module. The support frame is mounted by screwing it to the flush-type bus coupler and, for multiple combinations, also to the wall.

Thanks to the anti-fingerprint surface, the stainless steel Busch-priOn® is easy to keep clean and maintains its sophisticated surface finish even when it is in use. Glass surfaces and end strips match the **carat®** series.

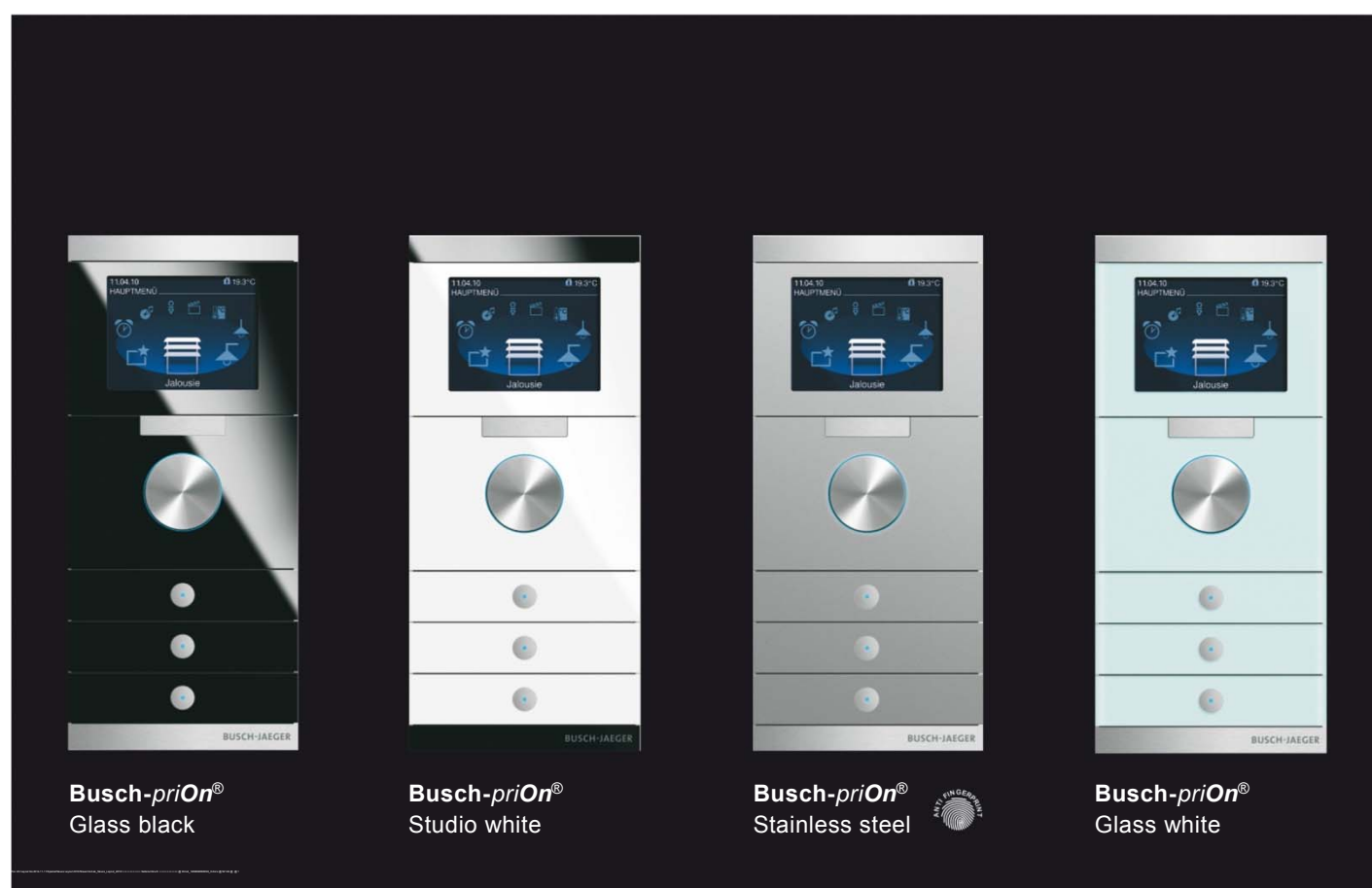

8 Room temperature controller operation

8.1 Room thermostat with display

8.1.1 Standard view



The display of the room thermostat shows either the current room temperature or the setpoint for the temperature, depending on the parameterization.

The current operating state is shown in the left area of the display and the current operating mode in the right area.

8.1.2 Set values



<input type="radio"/> Temperature -	<input type="radio"/> Temperature +
<input checked="" type="radio"/> Next setpoint	<input checked="" type="radio"/> Previous setpoint

<input type="radio"/> Comfort/Standby	<input type="radio"/> FanCoil-Steps
<input checked="" type="radio"/> On/Off	

- Short press Long press

In the setting level, which is accessed by pressing the additional key once, the setpoints for heating and/or cooling can be adjusted.

The corresponding setpoints are located to the right of each respective symbol for heating or cooling.

The value brightly highlighted can be changed.

The adjustment is made with the upper rocker of the control element. A short press of the left side lowers the setpoint, a short press of the right side raises the setpoint. With a long press of the button the selection jumps to the next setpoint. This one can now also be adjusted with a short press of the button.

After an adjustable time, the display returns to the standard view.

8.2 Operating modes



Standby: Standby mode lowers the temperature below the value of comfort mode. This saves energy and does not cool down the room even during an extended absence.



Comfort: Comfort mode regulates the temperature to suit the occupants while present. It can be called up time-controlled or via a telegram.



Dew point: If an appropriate telegram is received from a dew point sensor, the room thermostat will display the corresponding symbol and cease cooling and merely protect against the heat.



Alarm: The alarm can be freely parameterized. For example, it can occur when an external temperature sensor no longer sends values.



On/Off: The room thermostat can be turned on and off. When turned off, this icon is shown in the display. The device operates in frost protection mode.



Night setback: The temperature can be reduced during the night. This saves energy and makes the night's rest comfortable. The heating starts again automatically the next morning to reach a comfortable temperature for rising.



Frost protection: If parameterized, frost protection will ensure that the temperature does not drop below the desired value. It is the lowest setpoint.



Heat protection: If parameterized, heat protection will ensure that the temperature does not exceed the desired value. It is the highest setpoint.



Condensate: The operation of a fan coil may cause condensate water, which is collected in a container. If the fan coil sends out a telegram when the container is full, the symbol for condensate mode is displayed. The room thermostat immediately switches into heat protection mode.

9 Room temperature controller operation (only 6351/08-825-500 + 6344-101-500 [from update version 0.1.6.0])

9.1 Busch-priOn 8.89 cm display 6344-xxx-101-500

On the 8.89 cm display the current RTC will be replaced by the "Unified RTC".
The update to the new "Unified RTC" is carried out via the SD card slot of the device.



Note













The RTC functions are not compatible, which means that after the successful update the user must re-parameterize and re-commission the RTC.

9.1.1 Operating process

The RTC is operated by calling up the desired controller from the list menu. The function is selected with the aid of the rotary control element. Confirm by pressing the rotary control element.

9.1.2 Operating functions

The following functions are available to the user:

Display	Function	
	Setpoint adjustment	To change the setpoint temperature, select it via the rotary control element and press it to confirm the change. The setpoint is adjusted by turning the rotary control element. The adjustment is taken over by pressing the rotary control element. The respective active mode (heating or cooling) is displayed by means of the corresponding colour of blue or orange. If the adjustment is carried out within the parameterized hysteresis heat/cooling, the background is illuminated in white. If the threshold value is exceeded or drops below the required value, this is displayed in the setpoint display via the colour orange (heating) or blue (cooling).
	ECO mode	If the ECO mode is selected, this can be activated by pressing on the rotary control element. The display then changes to the ECO icon: - The other functions of the RTC are blocked. - Deactivation is carried out by again pressing or turning the rotary control element. The screen switches back to the overall view.
	OFF	Selection of function and confirmation by pressing the rotary control element. The display then changes to the OFF icon:
 	Fan coil	Selection of the fan coil function and confirmation by pressing the rotary control element. - The fan speed level is adjusted manually by turning the rotary control element. The adjustment is taken over by pressing the rotary control element.
 	Switchover Heating/cooling	Selection of heating/cooling switchover. Optional switching between heating function and cooling function is carried out by toggling the rotary control element. The respective function is displayed via the corresponding icon.
Alarm functions	The alarm functions are indicated in grey in the centre via the corresponding icon in the display. Local operation is blocked. The blockage is indicated via the blockage symbol at the top left in the window. It can be deactivated only by cancelling the alarm.	
	Frost/heat protection	
	Condensation	
	Dew point	
	Comfort mode	
	Standby mode	
	ECO mode	

9.1.3 Info line

The status of the internal controller is displayed at the left in the info line. The active operating mode, e.g. ECO mode, is displayed via the icon in green. The heating or cooling status is shown via the respective colour blue or orange.

9.1.4 Busch-priOn® top end strip with display 6351/08-825-500











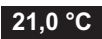

The end strip has been supplemented with the operation of the 1gang rotary control element 6341-xxx-101-500 for room temperature controller operation. The 3gang control element and the 1gang rotary control element are selected via the parameter setting. Starting from the 2gang support frame the 1gang rotary control element can be combined with other models of the Busch-priOn product range. When using the 1gang support frame in connection with the rotary control element, this combination only has one pure room temperature controller with rotary control and display. The bottom end strip with temperature sensor is to be used for the local measurement of the temperature.

9.2 Combination with 3gang control element 6342-xxx-101-500

9.2.1 Operating process

Operation is carried out by pressing the additional key on the end strip. The device changes to the RTC adjustment level. This change is indicated via an inverse display of the setpoint temperature (white with black numbers). The jump-back to the first operating level occurs after a waiting period of 3 seconds or with a renewed press of the additional key.

The following functions are available to the user:





Display	Function	
	Setpoint adjustment	The setpoint adjustment is made via the topmost rocker left/right.
	ECO mode	If the ECO mode is selected, this can be activated by pressing on the rotary control element. The display then changes to the ECO icon: - The other functions of the RTC are blocked. - Deactivation is carried out by again pressing or turning the rotary control element. The screen switches back to the overall view.
	OFF	The device is switched off by pressing the centre left rocker half. The function is displayed in the centre of the display via the corresponding icon. - It can only be deactivated with a renewed press of the left rocker.
 1 	Fan coil	The fan coil is operated via the bottom left rocker half. The active fan speed level is displayed in the centre of the display. The adjustment is performed with a renewed press of the rocker until the desired manual fan speed level is selected. It is displayed in the centre of the display and consists of the fan icon and the active fan speed level.
 	Switchover heating/cooling	The user can switch between heating and cooling via the bottom right rocker (if parameterized).
Alarm functions	The alarm functions are indicated in the centre via the corresponding icon in the display. Local operation in the RTC operating level is blocked. It can be deactivated only by cancelling the alarm.	
	Frost/heat protection	
	Condensation	
	Dew point	
	Comfort mode	
	Standby mode	
	ECO mode	





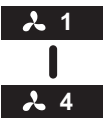

9.3 Combination with 1gang rotary control element 6341-xxx-101-500

9.3.1 Operating process









The RTC is operated by calling up the desired controller from the list menu. The function is selected with the aid of the rotary control element. Confirm by pressing the rotary control element.

The following functions are available to the user:

Display	Function	
	Setpoint adjustment	<p>The current setpoint is indicated directly. The setpoint is adjusted by turning the rotary control element. The adjustment is taken over after a waiting period. The active mode (heating or cooling) is displayed via the corresponding icon on the left next to the setpoint, and the respective function is simultaneously displayed via the coloured backlighting of the rotary control element.</p> <p>If the adjustment is carried out within the parameterized hysteresis heat/cooling, the background is illuminated in white. If the threshold value is exceeded or drops below the required value, this is displayed on the rotary control element via the colour orange (heating) or blue (cooling).</p>
	ECO mode	<p>The ECO mode is activated by pressing the rotary control element. The display then changes to the ECO icon:</p> <ul style="list-style-type: none"> - The other functions of the RTC are blocked. - Deactivation is carried out by again pressing or turning the rotary control element. The screen switches back to the overall view. The rotary control element is backlit in green.
	OFF	<p>The function is selected by pressing and turning the rotary control element until the desired OFF function is indicated in the display via the corresponding icon. The OFF function is activated with a press. The display then changes to the OFF icon:</p> <ul style="list-style-type: none"> - The other functions of the RTC are blocked. - The controller is switched on with a renewed press. The screen switches back to the overall view. - The rotary control element is backlit in white.
	Fan coil	<p>The function is selected by pressing and turning the rotary control element until the desired fan coil function is indicated in the display via the corresponding icon. The fan coil function is activated with a press. The active fan speed level is displayed in the centre of the display. The adjustment is performed by turning the rotary control element until the desired manual fan speed level is selected. It is displayed in the centre of the display and consists of the fan icon and the active fan speed level:</p> <ul style="list-style-type: none"> - Confirm with a renewed press or after waiting period. - The rotary control element is backlit in white.
	Switchover heating/cooling	<p>The function is selected by pressing and turning the rotary control element until the desired heating/cooling function is indicated in the display via the corresponding icon. Optional switching between heating function and cooling function is carried out by toggling the rotary control element. The respective function is displayed via the corresponding icon.</p> <ul style="list-style-type: none"> - The rotary control element is backlit in white.

Alarm functions	The alarm functions are indicated in the centre via the corresponding icon in the display. Local operation is blocked. It can be deactivated only by cancelling the alarm.	
	Frost/heat protection	
	Condensation	
	Dew point	
	Comfort mode	
	Standby mode	
	ECO mode	

9.3.2 Operating modes

	Comfort: Comfort mode regulates the temperature to suit the occupants while present. It can be called up time-controlled or via a telegram.
	Standby: Standby mode lowers the temperature during presence below the level of comfort mode. This saves energy. And the room does not cool down during an extended absence.
	Dew point: If an appropriate telegram is received from a dew point sensor, the room temperature controller will display the corresponding icon and cease cooling and merely protect against the heat.
	Alarm: The alarm can be freely parameterized. For example, it can occur when an external temperature sensor no longer sends values.
	On/Off: The room temperature controller can be switched on and off. This icon is displayed if the control is switched off. The device operates in frost protection mode.
	<p>Frost protection: If parameterized, frost protection will ensure that the temperature does not drop below the desired value. It is the lowest setpoint.</p> <p>Heat protection: If parameterized, heat protection will ensure that the temperature does not exceed the desired value. It is the highest setpoint.</p>
	Condensate: The operation of a fan coil may cause condensate, which is collected in a container. If the fan coil sends out a telegram when the container is full, the icon for condensate mode is displayed. The room temperature controller switches automatically into heat protection mode.
	ECO: ECO mode lowers the temperature to the programmed setting. This saves energy. And the room does not cool down during an extended absence.

10 Planner support for RTC

10.1 Operating modes

The room temperature controller has four operating modes:

- **Frost protection mode** (for heating): The room temperature control is inactive; heating is only carried out when the temperature in the room drops to the point where the heating system could sustain damage through freezing.
Heat protection mode (for cooling): The room temperature control is inactive; cooling is only carried out when the temperature has risen to the point where the heat in the room becomes unbearable.
- **Comfort mode** (for heating and cooling): The setpoint for the room temperature is set to a value that makes the temperature of the room comfortable during "normal use".
6351/08-825-500 + 6344-101-500 [from update version 0.1.6.0]:
Comfort mode is always active during manual operation (primary function).
- **Standby mode** (for heating): The room temperature is reduced to the point where heating costs are saved (e.g. during temporary absence), but can be quickly raised to comfort temperature again.
Standby mode (for cooling): The room temperature is only raised to the point where energy costs are saved (e.g. during temporary absence), but can be quickly increased to comfort temperature again.
6351/08-825-500 + 6344-101-500 [from update version 0.1.6.0]:
Standby mode cannot be set on the device. It is can only be activated via the KNX bus. Indicated in the display via the icon.
- **Night mode** (for heating and cooling): Rooms are not used for longer periods during the night hours; the room temperature is set to a comfortable night-time value and can be quickly raised again to the comfort setpoint in the morning.
6351/08-825-500 + 6344-101-500 [from update version 0.1.6.0]:
Night mode has been replaced by ECO mode. This can also be activated locally. Indicated in the display via the icon.

A switchover between these operating modes can take place either by means of a switching telegram (parameter "Operating mode switchover": "1 bit (3x)") or with 1-byte value telegrams (parameter "Operating mode switchover": "1 byte (2x)").

10.1.1 Operating mode switchover, 1 bit

Frost/heat protection has the highest priority; i.e., switchover to a different mode cannot take place in this case. The frost/heat protection must first be deactivated; by closing an open window, for example. Night mode has the next highest priority, followed by comfort mode. If none of these three operating modes are active, the room temperature controller is in standby mode.

6351/08-825-500 + 6344-101-500 [from update version 0.1.6.0]:

The 1-bit operating mode switchover is not available for this!

10.1.2 Operating mode switchover, 1 byte

Two 1-byte communication objects are made available with operation mode switchover via 1 byte.

The two 1-byte communication objects have different behaviours for receipt of telegram. One object evaluates received telegrams as "normal". This means, for example, if a comfort telegram is received, the room thermostat switches to comfort mode. If a night telegram is received, the room thermostat switches to night mode. This object is controlled, for example, by time switches.

The second object ("Operating mode switchover OMO") can "overwrite" the first. This means, for example, if a frost/heat protection telegram is received, the room thermostat switches to frost or heat protection mode. If frost or heat protection is reset after receipt of a new telegram, the room thermostat activates the mode that is pending on the "normal" object. As a result, it is capable of memorising operating modes. This object is controlled, for example, by binary inputs that record information from window contacts.

The following conditions apply for both 1-byte communication objects:

- 0 = Auto (only for "Operating mode switchover OMO")
- 1 = Comfort
- 2 = Standby
- 3 = Night
- 4 = Frost/Heat protection
- 5 – 255 = not allowed

10.1.3 Monitoring

The "Temperature measurement monitoring" parameter specifies whether the external temperature sensor and the outside temperature are to be monitored. This means that the room thermostat has to receive at least one telegram with the current temperature on the associated communication object within an adjustable time ("Monitoring time of external temperature" and "Monitoring time of outside temperature").

If no telegram is received during monitoring time, the room thermostat assumes that the measuring sensor for the outside temperature or external temperature is defective or no longer connected to the bus.

The room thermostat will then terminate its control and send a predefined control value ("Control value during temperature measurement error") so that the room to be controlled does not overheat or cool down. This control value is sent out until the room thermostat again receives a temperature telegram via the bus and reactivates the control.

10.1.4 External temperature sensor

In open-plan offices it can be difficult to control the temperature with only a single thermostat. That is why it would be advantageous to divide the room into zones with an additional room thermostat.

To integrate the temperature value of the additional temperature sensor into the temperature control, the parameter "Room temperature measurement" must be set on "Internal and external". The the temperature measured inside and outside can then be additionally weighted. The setting for weighting depend on the local circumstances. If the room thermostat and the additional measuring sensor are positioned equal distances from the heater, in the case of panel heaters, a 50% / 50% setting should provide good control results.

10.1.5 Adjustment

If the measured temperature is distorted, such as by the inherent heat of the bus coupler, an "Offset room temperature measurement" can be set.

If additional external temperature recording has been activated and the measured value becomes distorted through the influence of cold or heat, here, too, an offset can be entered.

10.2 Controller

The room thermostat can be used exclusively for heating, exclusively for cooling or for heating and cooling.

If the room thermostat is to heat or cool, the switchover from heating to cooling or cooling to heating can occur automatically by means of the room thermostat. The controller detects automatically whether a control value for heating or cooling is to be sent out. If the automatic switchover is not required, the switchover between heating and cooling can take place by means of an external, central control via the 1-bit object "Switchover heating/cooling". In this setup, the heat and cooling icons are continuously displayed in the respective mode. The object is enabled via parameter "Switchover between heating/cooling". The control value for heating and/or cooling can be sent out on a common communication object "Heating/cooling control value" or on two individual communication objects "Heating control value" and "Cooling control value". If a common object is used, it may be necessary to inform the actuator whether the control value is for heating or cooling. For this, a 1-bit communication object "Switchover heating/cooling" can be enabled via parameter "Switchover between heating and cooling" with setting "Automatic and sending". For activation of heating operating mode a "1" is sent to the bus, for activation of cooling mode a "0".

A common communication object for heating and cooling is required to activate two two-pipe systems, i.e., the same pipeline is used for heating and cooling. Two single communication objects are used for four-pipe systems. Heating and cooling each have their own pipeline system.

Parameter "Number of output channels" specifies whether an object ("1 channel (two-pipe system) for heating and cooling") or two objects ("2 channels (four-pipe system) for heating and cooling") are to be displayed.

Separate control types can be configured each for heating and cooling. One of the following control types can be selected:

- 2-point
- PWM
- Continuous
- Fan coil

The individual control types are described in greater detail in the following.

10.2.1 2-point controller

A 2-point controller has two output states that alternate in dependence of the actual value. If the actual value is above the parameterised setpoint, control value "0" is sent on the bus. If the actual value is below the parameterised setpoint, control value "1" is sent.

A 2-point controller should be used when the control value is to alternate only between the two states ON and OFF, such as an electrothermal valve that is connected to a switch actuator, for example. A 2-point controller can quickly correct control variations in case of large changes in the control variable, but never comes to rest.

To avoid rapid oscillations of the output states, the 2-point controllers always have a built-in hysteresis that varies around the setpoint. The hysteresis can have different size parameters. For example, if the setpoint during heating mode is 21 °C and the hysteresis is 1.0 K, the controller switches on when the value falls below 20.5 °C and switches off again when exceeding 21.5 °C. The "Hyteresis" parameter to be set, on the one hand responds to how quickly the heating can heat the room or how quickly the air-conditioning cools the room, and on the other hand to the desired temperature of the people in the room. The hysteresis should not be set too small, otherwise the switching actuator will constantly open and close. The hysteresis should also not be set too large, otherwise the temperature fluctuations in the room will be too large.

10.2.2 Continuous controller

A continuous controller has a continuously changing control value which can accept values between 0 and 100%. For the KNX this control value signal is converted to a 1-byte value, which means that control value 0% corresponds to value "0" and control value 100% to value "255".

Continuous controllers with a 1-byte control value, for example, can be used to activate electromotive actuating drives. They translate the value received directly into the valve position via an installed motor. This results in optimum control.

The 1-byte control value of a continuous controller can also be sent to KNX heating actuators which convert the 1-byte signal into a PWM size. This allows electrothermal valves to be activated. Here it is practical to limit the dynamic range since electrothermal valves require time to open and close. This takes place via parameters "Minimum control value" or "Maximum control value". If, for example, a maximum control value of 80% is specified, the control will always automatically send the value 255 when the control value of 204 has been exceeded.

To protect the bus from unnecessary loads the change of the control value that is permitted to be sent to the bus can be set. The setting is in percent. The control value sent, unless it has changed, is specified by means of a cycle time. The cycle time selected should not be too small (e.g. every 10 min.).

10.2.3 PWM controller

The PWM controller has the same continuous control as the continuous controller. The difference is that with a PWM controller the 1-byte control value (0...255) is converted into an On/OFF switching relationship (0 and 1). If, for example, a control value of 70% is to be issued, at a pre-set cycle time of 10 minutes the switch-on time will be 7 minutes and the switch-off time 3 minutes.

This transfers the advantages of the continuous control (control at the desired setpoint, no overshooting) to drives which are designed only for On/Off switching signals, such as electrothermal drives.

To optimise the controlling characteristics of the heating/cooling system, the "PWM control value cycle time" can be set. To set a practical cycle time, the type of heating or cooling as well as the actuating drive used should be taken into consideration. The following recommendations can be used:

- Electrothermal actuating drive
To fully open an electrothermal control valve takes approximately 2-3 minutes. That is why a cycle time of less than 15 minutes is not practical.
- Floor heating
The time constant of floor heating is rather large. That is why a cycle time of 20 minutes is sufficient.
- Hot water heating
Her electrothermal drives are generally used. A cycle time of 15 minutes will produce excellent control results.
- Electro-convector heating
Cycle times of between 10 and 15 minutes are recommended, depending on the electric heating system and the spatial circumstances.

10.2.4 Fan coil

With the selection of fan coil for "Control types" the control value output takes place in the same way as described under Continuous control.

With 'fan coil' there is the additional option of activating fan stages via a 1-byte or three 1-bit communication objects.

The added connection of the fan stages heats or cools the room correspondingly faster.

Which fan stage is to be active at which control value is specified on a separate tab "Fan coil heating" or "Fan coil cooling".

Here it should be ensured that threshold value stage 1 must always be smaller than threshold value stage 2, which in turn must be smaller than threshold value stage 3.

10.2.5 Control parameter for PWM controller and continuous controller (Fan coil)

For continuous control behaviour and for a switching PWM controller, the preset control parameters can be used via the installation type of the heating or cooling system. If different control parameters are required, they should be set individually via user parameterization. User parameterization should only be used by persons with adequate experience in control technology.

The setting "User parameterization" can be used to set the "Proportional range (Xp)" and the "Readjust time (Tn)". The proportional range lies below and above the preset setpoint and determines the regulating speed. The readjust time amounts to three times the delay time. The delay time is determined by the reversing tangent of the heating curve of the room. In general, the more inactive the overall system, the larger the parameterization values should be.

10.2.6 Two-stage heating / cooling

In specific instances such as when using underfloor heating, it may be necessary to install a quick additional stage for the heat control in order to warm up the room rapidly. When the room thermostat is preset to "Additional heating stage active", it has a second heating system with switching control that regulates with the 1-byte values 0% and 100%.

The parameters "Distance of the additional stage" and "Hysteresis (one-sided)" enable you to specify when the additional stage switches on and off. For instance, if the setpoint for the additional stage is 18 °C and the hysteresis is 0.5 K (one-sided), the controller switches on at 18 °C and off again at 18.5 °C.

The settings for the additional heating stage apply equally to the additional cooling stage, the only difference being that in the case of cooling, when a set temperature has been exceeded, an additional cooling stage is switched on to cool the room faster.

Since several actuating drives close (opened de-energised) at a 1-bit value of "1" or a 1-byte value of "255" and open at "0", the mode of the control value can be changed via "Invert control value".

10.3 Set values

The room thermostat can operate with dependent or individual set values. Both versions are explained in greater detail in the following.

10.3.1 Dependent setpoints

In case of dependent setpoints there are two basic setpoints, one for heating ("Heating setpoint comfort operation" and one for cooling ("Cooling setpoint comfort operation").

The settings "...lowering standby/night mode" or "...raising standby/night mode". This means, for example, when 21 °C has been set for "Heating setpoint comfort mode" and 2 K was specified for "Lower heating setpoint standby", the heating setpoint in standby mode is lowered by 2 K to 19 °C. If 4 K has been specified for "Lower heating setpoint standby", the setpoint for "Heating setpoint for night mode" is 17 °C.

The dependence of the setpoints are also maintained after a manual setpoint shift. For example, when the user has effected a setpoint shift of 1 K upward to 22 °C for the parameterized temperature "Heating setpoint comfort mode", this value will be lowered by 2 K to 20 °C when comfort mode is activated. When night mode is called up, the value will be lowered by 4 K, resulting in a setpoint of 18 °C.

The user can manually change the parameterized setpoints via the two buttons "Raise temperature" or "Lower temperature". The change between "Heating setpoint comfort mode" and "Cooling setpoint comfort mode" is made via a long press (approx. 1 sec.) of button "Raise temperature" to heating setpoint and on button "Lower temperature" to cooling setpoint.

The two specified setpoints for heating and cooling can also be changed as often as desired via the bus without the ETS. Here a 2-byte temperature value must be sent to the communication object "Base setpoint - control". Depending on whether heating or cooling is currently active, the value is stored as "Heating setpoint comfort mode" or "Cooling setpoint comfort mode". The values received are stored in the memory of the device and are retained in case of bus power failure and subsequent return of bus voltage. This makes it possible to send new base setpoints to the device via a visualization when the use of a room changes, for example.

New parameterization is not required. In case of a manual adjustment and dependent setpoints the reference base setpoint is taken into consideration. This is used to specify whether the base setpoint refers to the comfort temperature for heating, cooling or the mid-range temperature between heating and cooling.

"Setpoint heating" is the default setting. In regions where the cooling function is more important, it is recommended that you change this parameter to "Setpoint cooling". This makes it easier to set the room thermostat and raise the cooling setpoint (standby temperature cooling and night setback cooling).

10.3.2 Individual setpoints

When individual setpoints are used, individual setpoints are defined for each operating mode ("Heating setpoint comfort mode", "Heating setpoint standby", "Heating setpoint night mode", "Cooling setpoint standby" and "Cooling setpoint night mode").

Different to the dependent setpoints, the individual setpoints are also maintained after a manual setpoint shift. For example, when the user has effected a setpoint shift of the parameterized temperature "Heating setpoint comfort mode" upward or downward, the parameterized value "Heating setpoint standby" will always be called up when standby mode is activated. This means that only the fixed setpoints that are stored will be called up for the individual operating modes.

The user can manually change the parameterized setpoints via the two buttons "Raise temperature" or "Lower temperature". The change between "Heating setpoint comfort mode" and "Cooling setpoint comfort mode" is made via a long press (approx. 1 sec.) of button "Raise temperature" to heating setpoint and on button "Lower temperature" to cooling setpoint. The specified setpoints can be changed as often as desired via the bus also without the ETS. For this, a 2-byte temperature value must be sent to the corresponding communication object "Setpoint heating comfort", "Setpoint heating standby", "Setpoint heating night mode", "Setpoint frost protection", "Setpoint cooling comfort", "Setpoint cooling standby", "Setpoint cooling night mode" or "Setpoint heat protection". The values received are stored in the memory of the device and are retained in case of bus power failure and subsequent return of bus voltage. This makes it possible to send new setpoints to the device via a visualization when the use of a room changes, for example. New parameterization is not required.

10.3.3 Minimum distance

The adjustable parameter "Minimum distance between heating and cooling" is active both for the dependent and the individual setpoints.

The minimum distance is always between "Heating setpoint comfort mode" and "Cooling setpoint comfort mode". It serves as a buffer zone to prevent the the two setpoints from interfering with each other.

Example:

Individual setpoints has been selected. The "Heating setpoint comfort mode" is 21 °C and the "Cooling setpoint comfort mode" is set on 26 °C. The dead zone between heating and cooling is 3 K. If a heating setpoint is now shifted upwards, the dead zone also shifts upwards. If the shift exceeds a temperature of 23 °C, the "Cooling setpoint comfort mode" will also shift upwards so that a minimum distance of 3 K is always guaranteed between heating and cooling.

If a cooling setpoint is shifted downwards, the dead zone also shifts downwards. If the shift exceeds a temperature of 24 °C, the "Heating setpoint comfort mode" will also shift downwards so that a minimum distance is also guaranteed in this case.

10.4 Fan coil, general

The ventilation convectors, also called fan convectors or fan coil units, are used for decentralized heating and cooling. They are installed in the room and supplied via a central heating and cooling system. There are two-pipe and four-pipe systems. There are multi-stage ventilators within a fan coil unit that enable fast adjustment to the room temperature to be made according to individual requirements. The fan coil room thermostat with display can activate up to three fan stages either manually or automatically.

The fan stages can be activated in three ways:

- via 1-bit values,
i.e., a 1-bit communication object "Fan coil stage ... switching" is made available for each fan stage. This required for "normal switch actuators. ((When using KNX switch actuators and fan coil units, the connecting instructions for the fan coil unit are to be observed).
- via 1-byte object as numerical value 0-3,
i.e. there is a 1-byte communication object "Fan stage manual 1 byte" which is connected with a corresponding communication object of a fan coil actuator. Here the value 0 = OFF 1 = stage 1 2 = stage 2 3 = stage 3
- via 1-byte object as constant value 0-100%,
i.e. there is a 1-byte communication object "Fan stage manual 1 byte" which is connected with a corresponding communication object of a fan coil actuator. During manual stage switchover the stage threshold values that are set on tab heating or cooling are sent out. In heating mode the threshold values for heating, in cooling mode the threshold values for cooling. To ensure that the fan coil unit switches the fan stages, the parameters of the associated fan coil actuator must be set accordingly.

Via parameter "Evaluate fan stage status byte" a 1-byte communication object "Fan coil operating state", which is connected with a corresponding object of a fan coil actuator, can be enabled. This allows the fan coil room thermostat evaluate which fan stage is actually active on the fan coil actuator. The display corresponds to the value of the communication object (0 = OFF, 1 = stage 1, 2 = stage 2, 3 = stage 3).

The parameter "Evaluate operation status byte" activates a 1-bit communication object "Receive during operation - actuator monitoring". Cyclical telegrams from the fan coil actuator can be received and evaluated on this object. This allows the room thermostat to check whether the fan coil actuator is still operating and can be activated. If the fan coil actuator has a problem and can no longer send cyclical telegrams, the room thermostat will indicate this on the display with the "Error" symbol. If the error on the fan coil actuator has been rectified and cyclical telegrams can be received, the "Error" on the display is removed and the room thermostat will again function as "Normal".

The cycle time setting "In operation" in the fan coil actuator should be selected at least twice as large as the monitoring time in the room thermostat ("Sending cycle time of actuator in sec."). A practical cycle time for the actuator is approximately 60 seconds with a monitoring time of 120 seconds for the room thermostat.

To prevent an excessive noise level in hotel rooms during the silent period in the night, a "Stage limitation for night mode" can be set. This means that during night mode only the fan stage that has been set is automatically switched to. All fan stages can be activated again when changing to a different operating mode.

Parameter "Stage limitation for night mode" can be used to set a limit to "Stage 2" or "Stage 1" or the ventilation can be completely deactivated.

10.5 Compensation

The fan coil room thermostat with display has the two compensation types, summer and winter compensation. Each is explained in greater detail in the following.

10.5.1 Summer compensation

To save energy and to maintain a reasonable temperature difference when entering an air-conditioned building, the room temperature should be adjusted in relation to the external temperature (summer compensation according to DIN 1946). The room temperature is raised by adjusting the "Cooling setpoint comfort mode".

Raising the room temperature does not, however, mean that you heat up the room. Rather the adjustment is intended to allow the room temperature without cooling to increase to a specified value. This prevents the cooling system from further reducing the room temperature to 24 °C with an external temperature of 35 °C.

However, the activation of summer compensation makes an external temperature sensor necessary that sends its measured value to the KNX for evaluation by the room thermostat with display.

The following parameters are available for summer compensation:

- "Summer compensation lower outside temperature value"
- "Summer compensation upper outside temperature value"
- "Summer compensation lower setpoint offset"
- "Summer compensation upper setpoint offset"

The value of the lower and upper temperature is used to specify from and to which temperature value a setpoint correction is to be made.

The lower and upper setpoint offset is used to specify by how many Kelvin the setpoint specified in the parameters or by the user via a manual shift is to be adjusted during summer compensation.

Typical values for the summer compensation are:

- 20 °C: lower outside temperature value
- 32 °C: upper outside temperature value
- 0 K: lower setpoint offset
- 4 K: upper setpoint offset

That means that a flowing setpoint increase of 0 to 4 K occurs if the outside temperature increases from 20°C to 32°C.

Example:

In the lower diagram 25 °C has been parameterized for "Cooling setpoint comfort". When the outside temperature rises, the parameterized setpoint is raised starting from an outside temperature of 20 °C flowing from 25 °C to 29 °C. The 29 °C are reached at an outside temperature of 32 °C. After this the setpoint is no longer raised even though the outside temperature rises.

Note:

When compensation is active, CO is shown on the display of the room thermostat.

10.5.2 Winter compensation

To improve comfort and to keep the temperature difference when entering a room with large window areas within comfortable limits, an increase of the room temperature in dependence of the outside temperature should be performed during the winter (winter compensation). The room temperature is raised by adjusting the "Heating setpoint comfort mode". However, similar to summer compensation, winter compensation makes an external temperature sensor necessary that sends its measured value to the KNX for evaluation by the room temperature controller with display.

The following parameters are available for winter compensation:

- "Winter compensation lower outside temperature value"
- "Winter compensation upper outside temperature value",
- "Winter compensation lower setpoint offset",
- "Winter compensation upper setpoint offset".

The value of the lower and upper temperature is used to specify from and up to which temperature value a setpoint correction is to be made.

The lower and upper setpoint offset is used to specify by how many Kelvin the setpoint specified in the parameters or by the user via a manual shift is to be adjusted during winter compensation.

Typical values for the winter compensation are:

- 0°C: lower outside temperature value
- 10°C: upper outside temperature value
- 4 K: lower setpoint offset
- 0 K: upper setpoint offset

That means that a flowing setpoint increase from 0 to 4 K occurs if the outside temperature falls from 10°C to 0°C.

For example:

In the lower diagram 21°C has been parameterized for "Heating setpoint comfort". When the outside temperature falls, the parameterized setpoint is raised starting from an outside temperature of 10°C flowing from 21°C to 25°C. The 25°C are reached at an outside temperature of 0°C. After this the setpoint is no longer raised even though the outside temperature continuous to fall.

Note...

When compensation is active, "CO" is shown on the display.

6351/08-825-500 + 6344-101-500 [from update version 0.1.6.0]:

Winter compensation is not available for this!

11 Description of application

(without room temperature control 6351/08-825 + 6344-101-500 [from update version 0.1.6.0] -> see separate chapter)



6351/08-825-500 + 6344-101-500 [from update version 0.1.6.0]:

When using a native ETS application the user does not have all "General functions" (logics) available. This is only the case under PowerTool.

11.1 Switching, rocker total

With the "Switch, rocker total" application, an operation of the right or left side of the rocker sends out a switch telegram. The "Switch, rocker total" application differentiates here between whether the rocker is operated on the left or right side.

Switching objects, rocker total

No.	Object name	Data type	Flags
0	Switching	1 Bit EIS1 / DPT 1.001	C, W, T, U

11.2 Switching, rocker left/right

With the application "Switching, rocker left/right" a switch telegram is sent when the rocker is actuated and/or released. "Rocker left/right" does not differentiate whether the rocker is actuated on the right or the left side. In each case, the application makes a separate set of parameters and communication objects available for the right and left side of the rocker. The application enables a switching function to be implemented with one side of the rocker and to assign an additional "button-oriented" function to the other side of the rocker.

Switching objects, rocker left/right

No.	Object name	Data type	Flags
0	Switching	1 Bit EIS1 / DPT 1.001	C, W, T, U

11.3 Dimming, rocker total

With the "Dimming, rocker total" application, a rocker has communication objects for switching and for dimming. A distinction is made between short and long button contact.

The "Dimming, rocker total" application differentiates between whether the rocker is operated on the left or right side. The "Principle of operation of the rocker for ..." parameter allows adjustment of whether the left or right side switches on or off or whether it is dimmed brighter or darker.

Dimming objects, rocker total

No.	Object name	Data type	Flags
0	Switching	1 Bit EIS2 / DPT 1.001	C, W, T, U
1	Relative dimming	4 Bit EIS2 / DPT 3.007	C, T

11.4 Dimming, rocker left/right

With the "Dimming, rocker left/right" application, a rocker switch has communication objects for switching and for dimming. A distinction is made between short (switching) and long (dimming) button contact.

The "Dimming, rocker left/right" application does not differentiate between whether the rocker is operated on the left or right side. In each case, the application makes a separate set of parameters and communication objects available for the right and left side of the rocker.

The application makes it possible to dim a light via one side of the rocker and to assign an additional "button-orientated" function to the other side.

Dimming objects, rocker left/right

No.	Object name	Data type	Flags
0	Switching	1 Bit EIS2 / DPT 1.001	C, W, T, U
1	Relative dimming	4 Bit EIS2 / DPT 3.007	C, T

11.5 Blind, rocker total

Via the application "Blind, rocker total", blind movement and/or slat adjustment commands can be sent to connected shutting actuators with a short or long contact of the rocker. A short button contact always triggers a slat adjustment or stop command and a long button contact always triggers a move command.

The control always remembers the last action performed on the side of the rocker switch that is assigned with the "Blind, rocker total" application. If a blind was lowered and halted at half height via a short button contact, then a renewed long button contact will raise the blind.

Blind objects, rocker total

No.	Object name	Data type	Flags
0	Adjusting(1 Bit)	1 Bit EIS7 / DPT 1.008	C, T
0	Adjusting (1 Byte)	1 Byte EIS6 / DPT 5.001	C, T
1	Move (1 Bit)	1 Bit EIS7 / DPT 1.007	C, T
1	Move(1 Byte)	1 Byte EIS6 / DPT 5.001	C, T

11.6 Blind, rocker left/right

Via the application "Blind, rocker left/right", blind movement and/or slat adjustment commands can be sent to connected shutting actuators with short or long actuation of the rocker. A short button contact always triggers a move command and a long button contact always triggers a slat adjustment or stop command.

The application "Blind, rocker left/right" makes a separate set of parameters and communication objects available in each case for the right or left side of the rocker. This facilitates control of a Venetian blind with one side of the rocker and assigning an additional "Rocker, left/right" function to the other side of the rocker.

The control always remembers the last action performed on the side of the rocker that is assigned with the "Blind, rocker left/right" application. If a blind was lowered and halted at half height via a long button contact, then a renewed short button contact will raise the blind.

Blind objects, rocker left/right

No.	Object name	Data type	Flags
0	Adjusting (1 Bit)	1 Bit EIS7 / DPT 1.007	C, W, T, U
0	Adjusting(1 Byte)	1 Byte EIS6 / DPT 5.001	C, W, T, U
1	Moving(1 Bit)	1 Bit EIS7 / DPT 1.008	C, W, T, U
1	Moving(1 Byte)	1 Byte EIS6 / DPT 5.001	C, W, T, U

11.7 Value sender, rocker total

With the "Value sender, rocker total" application, a telegram with the predefined value is sent out at an actuation of the right or left side of the rocker.

The "Value sender, rocker total" application differentiates here between whether the rocker is actuated on the left or right side.

Value sender objects, rocker total

No.	Object name	Data type	Flags
0	Switching value(1 Bit)	1 Bit EIS1 / DPT 1.001	C, W, T, U
0	Switching value(1 Byte 0..100 %)	1 Byte EIS6 / DPT 5.001	C, W, T, U
0	Switching value(1 Byte 0..255)	1 Byte EIS14 / DPT 5.010	C, W, T, U
0	Switching value(2 Byte Float)	2 Byte EIS5 / DPT 9.xxx	C, W, T, U
0	Switching value(2 Byte Signed)	2 Byte EIS10 / DPT 7.001	C, W, T, U
0	Switching value (2 Byte Unsigned)	2 Byte EIS10 / DPT 8.001	C, W, T, U
0	Switching value (4 Byte Float)	4 Byte EIS9 / DPT 14.xxx	C, W, T, U
0	Switching value (4 Byte Signed)	4 Byte EIS11 / DPT 13.001	C, W, T, U
0	Switching value (4 Byte Unsigned)	4 Byte EIS11 / DPT 12.001	C, W, T, U

11.8 Value sender, rocker left/right

With the "Value sender, rocker left/right" application, a telegram with a predefined value is sent out at an actuation or release of the rocker.

The "Value sender, rocker left/right" application does not differentiate between whether the rocker is actuated on the left or right side. In each case, the application makes a separate set of parameters and communication objects available for the right and left side of the rocker.

The application enables realising a switching function via one rocker side, while the other rocker side can be assigned with an additional "button-orientated" function.

Value sender objects, rocker left/right

No.	Object name	Data type	Flags
0	Switching (1 Bit)	1 Bit EIS1 / DPT 1.001	C, W, T, U
0	Switching (1 Byte 0..100 %)	1 Byte EIS6 / DPT 5.001	C, W, T, U
0	Switching (1 Byte 0..255)	1 Byte EIS14 / DPT 5.010	C, W, T, U
0	Switching (2 Byte Float)	2 Byte EIS5 / DPT 9.xxx	C, W, T, U
0	Switching (2 Byte Signed)	2 Byte EIS10 / DPT 8.001	C, W, T, U
0	Switching (2 Byte Unsigned)	2 Byte EIS10 / DPT 7.001	C, W, T, U
0	Switching (4 Byte Float)	4 Byte EIS9 / DPT 14.xxx	C, W, T, U
0	Switching (4 Byte Signed)	4 Byte EIS11 / DPT 13.001	C, W, T, U
0	Switching (4 Byte Unsigned)	4 Byte EIS11 / DPT 12.001	C, W, T, U

11.9 Value sender, 2 objects, rocker left/right

With the "Value sender, 2 objects, rocker left/right" application, two telegrams with predefined values from two different communication objects can be sent out by actuation and/or upon release of the rocker.

The application "Value sender, 2 objects, rocker left/right" makes a separate set of parameters and communication objects available in each case for the right or left side of the rocker.

For example, the application facilitates the sending out of a switching function and a floating point value with the actuation of one rocker side and assigning an additional "button orientated" function to the other side of the rocker.

Value sender objects, 2 objects, rocker left/right

No.	Object name	Data type	Flags
0	Switching (rising flank) (1 Bit)	1 Bit EIS1 / DPT 1.001	C, W, T, U
0	Switching (rising flank) (1 Byte 0..100 %)	1 Byte EIS6 / DPT 5.001	C, W, T, U
0	Switching (rising flank) (1 Byte 0..255)	1 Byte EIS14 / DPT 5.010	C, W, T, U
0	Switching (rising flank) (2 Byte Float)	2 Byte EIS5 / DPT 1.xxx	C, W, T, U
0	Switching (rising flank) (2 Byte Signed)	2 Byte EIS10 / DPT 8.001	C, W, T, U
0	Switching (rising flank) (2 Byte Unsigned)	2 Byte EIS10 / DPT 7.001	C, W, T, U
0	Switching (rising flank) (4 Byte Float)	4 Byte EIS9 / DPT 14.xxx	C, W, T, U
0	Switching (rising flank) (4 Byte Signed)	4 Byte EIS11 / DPT 13.001	C, W, T, U
0	Switching (rising flank) (4 Byte Unsigned)	4 Byte EIS11 / DPT 12.001	C, W, T, U
1	Switching (falling flank) (1 Bit)	1 Bit EIS1 / DPT 1.001	C, W, T, U
1	Switching (falling flank) (1 Byte 0..100 %)	1 Byte EIS6 / DPT 5.001	C, W, T, U
1	Switching (falling flank) (1 Byte 0..255)	1 Byte EIS14 / DPT 5.010	C, W, T, U
1	Switching (falling flank) (2 Byte Float)	2 Byte EIS5 / DPT 9.xxx	C, W, T, U
1	Switching (falling flank) (2 Byte Signed)	2 Byte EIS10 / DPT 7.001	C, W, T, U
1	Switching (falling flank) (2 Byte Unsigned)	2 Byte EIS10 / DPT 8.001	C, W, T, U
1	Switching (falling flank) (4 Byte Float)	4 Byte EIS9 / DPT 14.xxx	C, W, T, U
1	Switching (falling flank) (4 Byte Signed)	4 Byte EIS11 / DPT 13.001	C, W, T, U
1	Switching (falling flank) (4 Byte Unsigned)	4 Byte EIS11 / DPT 12.001	C, W, T, U

11.10 Value dimming sensor, rocker total

With the application "Value dimming sensor, rocker total", it is possible to send 1-byte telegrams by actuating the rocker. Each actuation of the left or right side of the rocker will increase or reduce a 1-byte value (percent or values from 0 to 255). The 1-byte value can be connected with 1-byte brightness value objects of dimming actuators. This allows a dimming actuator to be dimmed brighter or darker with the rocker via value telegrams.

Value dimming sensor objects, rocker total

No.	Object name	Data type	Flags
0	Value	1 Byte / EIS6/14 / DPT 5.001 / DPT 5.010	C, W, T, U

11.11 Light scene extension unit with memory function

Via the application "Light scene extension unit with memory function", a predefined light scene number is called up when the rocker is actuated.

The application "Light scene extension unit with memory function" makes a separate set of parameters and communication objects available in each case for the right or left side of the rocker.

The application facilitates calling up a light scene via a rocker side while the other rocker side can be assigned an additional "button orientated" function.

The user has the option to trigger a light scene memory command with a long button contact.

Light scene extension unit objects with memory function

No.	Object name	Data type	Flags
0	Switching	1 Byte EIS1 / DPT 1.001	C, W, T, U

11.12 Step switch, rocker total

The application "Step switch, rocker total" facilitates step-type switching. This means that the user can trigger different switching processes with each new operation of the left or right side of the rocker.

Example:

First operation (right rocker side) switches lamp 1 on.

Second operation (right rocker side) switches lamp 1 off and lamp 2 on.

Third operation (right rocker side) switches lamp 2 off and lamp 3 on.

Fourth operation (left rocker side) switches lamp 3 off and lamp 2 on.

Fifth operation (left rocker side) switches lamp 2 off and lamp 1 on.

etc.

The application differentiates between whether the left or right side of the rocker was operated. Depending on the setting, one lower or one higher step can be switched to.

Up to five switching steps can be activated.

Step switch objects, rocker total

No.	Object name	Data type	Flags
0	Switching step 1	1 Bit EIS1 / DPT 1.001	C, W, T
1	Switching step 2	1 Bit EIS1 / DPT 1.001	C, W, T
2	Switching step 3	1 Bit EIS1 / DPT 1.001	C, W, T
3	Switching step 4	1 Bit EIS1 / DPT 1.001	C, W, T
4	Switching step 5	1 Bit EIS1 / DPT 1.001	C, W, T

11.13 Step switch, rocker left/right

The application "Step switch, rocker left/right" facilitates step-type switching. This means that the user can trigger different switching processes with each new operation of the rocker switch.

Example:

First operation switches lamp 1 on.

Second operation switches lamp 1 off and lamp 2 on.

Third operation switches lamp 2 off and lamp 3 on.

Fourth operation switches lamp 3 off and lamp 1 on.

etc.

Up to five switching steps can be activated.

In each case, the application "Step switch, button oriented" makes a separate set of parameters and communication objects available for the right or left side of the rocker.

The application enables realising switching functions via one rocker side while the other rocker side can be assigned with an additional "button orientated" function.

Step switch objects, rocker left/right

No.	Object name	Data type	Flags
0	Switching step 1	1 Bit EIS1 / DPT 1.001	C, W, T
1	Switching step 2	1 Bit EIS1 / DPT 1.001	C, W, T
2	Switching step 3	1 Bit EIS1 / DPT 1.001	C, W, T
3	Switching step 4	1 Bit EIS1 / DPT 1.001	C, W, T
4	Switching step 5	1 Bit EIS1 / DPT 1.001	C, W, T

11.14 Multiple operation, rocker left/right

With the "Multiple operation, rocker left/right" application, a differentiation can be made between a single, double, triple, quadruple or quintuple operation of the rocker. Different values can be sent out for every operation: single, double, triple, quadruple, or quintuple.

The application "Multiple operation, rocker left/right" makes a separate set of parameters and communication objects available in each case for the right or left side of the rocker. It is therefore possible to realise a multiple operation via one side of the rocker and assigning a "button-orientated" function to the other side of the rocker.

Multiple operation objects, rocker left/right

No.	Object name	Data type	Flags
0	Switching 1, multiple operation (1 Bit)	1 Bit EIS1 / DPT 1.001	C, W, T
0	Switching 1, multiple operation (1 Byte 0..100 %)	1 Byte EIS6 / DPT 5.001	C, W, T
0	Switching 1, multiple operation (1 Byte 0..255)	1 Byte EIS14 / DPT 5.010	C, W, T
0	Switching 1, multiple operation (2 Byte Float)	2 Byte EIS5 / DPT 9.xxx	C, W, T
0	Switching 1, multiple operation (2 Byte Signed)	2 Byte EIS10 / DPT 8.001	C, W, T
0	Switching 1, multiple operation (2 Byte Unsigned)	2 Byte EIS10 / DPT 7.001	C, W, T
0	Switching 1, multiple operation (4 Byte Float)	4 Byte EIS9 / DPT 14.xxx	C, W, T
0	Switching 1, multiple operation (4 Byte Signed)	4 Byte EIS11 / DPT 13.001	C, W, T
0	Switching 1, multiple operation (4 Byte Unsigned)	4 Byte EIS11 / DPT 12.001	C, W, T

Multiple operation objects, rocker left/right, continued

No.	Object name	Data type	Flags
1	Switching 2, multiple operation (1 Bit)	1 Bit EIS1 / DPT 1.001	C, W, T
1	Switching 2, multiple operation (1 Byte 0..100 %)	1 Byte EIS6 / DPT 5.001	C, W, T
1	Switching 2, multiple operation (1 Byte 0..255)	1 Byte EIS14 / DPT 5.010	C, W, T
1	Switching 2, multiple operation (2 Byte Float)	2 Byte EIS5 / DPT 9.xxx	C, W, T
1	Switching 2, multiple operation (2 Byte Signed)	2 Byte EIS10 / DPT 8.001	C, W, T
1	Switching 2, multiple operation (2 Byte Unsigned)	2 Byte EIS10 / DPT 7.001	C, W, T
1	Switching 2, multiple operation (4 Byte Float)	4 Byte EIS9 / DPT 14.xxx	C, W, T
1	Switching 2, multiple operation (4 Byte Signed)	4 Byte EIS11 / DPT 13.001	C, W, T
1	Switching 2, multiple operation (4 Byte Unsigned)	4 Byte EIS11 / DPT 12.001	C, W, T
2	Switching 3, multiple operation (1 Bit)	1 Bit EIS1 / DPT 1.001	C, W, T
2	Switching 3, multiple operation (1 Byte 0..100 %)	1 Byte EIS6 / DPT 5.001	C, W, T
2	Switching 3, multiple operation (1 Byte 0..255)	1 Byte EIS14 / DPT 5.010	C, W, T
2	Switching 3, multiple operation (2 Byte Float)	2 Byte EIS5 / DPT 9.xxx	C, W, T
2	Switching 3, multiple operation (2 Byte Signed)	2 Byte EIS10 / DPT 8.001	C, W, T
2	Switching 3, multiple operation (2 Byte Unsigned)	2 Byte EIS10 / DPT 7.001	C, W, T
2	Switching 3, multiple operation (4 Byte Float)	4 Byte EIS9 / DPT 14.xxx	C, W, T
2	Switching 3, multiple operation (4 Byte Signed)	4 Byte EIS11 / DPT 13.001	C, W, T
2	Switching 3, multiple operation (4 Byte Unsigned)	4 Byte EIS11 / DPT 12.001	C, W, T
3	Switching 4, multiple operation (1 Bit)	1 Bit EIS1 / DPT 1.001	C, W, T
3	Switching 4, multiple operation (1 Byte 0..100 %)	1 Byte EIS6 / DPT 5.001	C, W, T
3	Switching 4, multiple operation (1 Byte 0..255)	1 Byte EIS14 / DPT 5.010	C, W, T
3	Switching 4, multiple operation (2 Byte Float)	2 Byte EIS5 / DPT 9.xxx	C, W, T
3	Switching 4, multiple operation (2 Byte Signed)	2 Byte EIS10 / DPT 8.001	C, W, T
3	Switching 4, multiple operation (2 Byte Unsigned)	2 Byte EIS10 / DPT 7.001	C, W, T
3	Switching 4, multiple operation (4 Byte Float)	4 Byte EIS9 / DPT 14.xxx	C, W, T
3	Switching 4, multiple operation (4 Byte Signed)	4 Byte EIS11 / DPT 13.001	C, W, T
3	Switching 4, multiple operation (4 Byte Unsigned)	4 Byte EIS11 / DPT 12.001	C, W, T
4	Switching 5, multiple operation (1 Bit)	1 Bit EIS1 / DPT 1.001	C, W, T
4	Switching 5, multiple operation (1 Byte 0..100 %)	1 Byte EIS6 / DPT 5.001	C, W, T
4	Switching 5, multiple operation (1 Byte 0..255)	1 Byte EIS14 / DPT 5.010	C, W, T
4	Switching 5, multiple operation (2 Byte Float)	2 Byte EIS5 / DPT 9.xxx	C, W, T
4	Switching 5, multiple operation (2 Byte Signed)	2 Byte EIS10 / DPT 8.001	C, W, T
4	Switching 5, multiple operation (2 Byte Unsigned)	2 Byte EIS10 / DPT 7.001	C, W, T
4	Switching 5, multiple operation (4 Byte Float)	4 Byte EIS9 / DPT 14.xxx	C, W, T
4	Switching 5, multiple operation (4 Byte Signed)	4 Byte EIS11 / DPT 13.001	C, W, T
4	Switching 5, multiple operation (4 Byte Unsigned)	4 Byte EIS11 / DPT 12.001	C, W, T

11.15 Short/long operation, rocker left/right

Via the application "Short/long operation, rocker left/right", different values can be sent out with a short and/or long actuation of the rocker switch.

The "Short/long operation, rocker left/right" application does not differentiate between whether the rocker is actuated on the left or right side. In each case, the application makes a separate set of parameters and communication objects available for the right and left side of the rocker.

The application facilitates making two separate functions available on one side of the rocker that can be called up via a short or long button contact and assigning the other side of the rocker switch with an additional "button-orientated" function.

Short/long operation objects, rocker left/right

No.	Object name	Data type	Flags
0	Adjusting(1 Bit)	1 Bit EIS7 / DPT 1.007	C, W, T, U
0	Adjusting(1 Byte)	1 Byte EIS6 / DPT 5.001	C, W, T, U
1	Moving (1 Bit)	1 Bit EIS7 / DPT 1.008	C, W, T, U
1	Moving (1 Byte)	1 Byte EIS6 / DPT 5.001	C, W, T, U

11.16 Setting RTC operation mode

With the "Setting the RTC operation mode" application, an operation mode switchover for connected room temperature controllers can be carried out via an actuation of a rocker side.

Depending on the setting of the "Object type for output" parameter, the application offers either three 1-bit communication objects "Operation mode comfort", "Operation mode night", and "Operation mode frost" or a 1-byte communication object "Operation mode".

The selection "1-bit" is used for the control of room temperature controllers that have 1-bit communication objects for operation mode switchover. The "1-byte" selection is used for the control of room temperature controllers that have a 1-byte communication object for operation mode switchover to KNX. In this case, the values mean

0 = Auto

1 = Comfort

2 = Standby

3 = Night

4 = Frost / Heat protection

The function can be temporarily blocked via a 1-bit "Enable" communication object.

Setting RTC operation mode objects

No.	Object name	Data type	Flags
0	Enable	1 Bit EIS1 / DPT 1.001	C, W, U
1	Operation mode Comfort(1 Bit)	1 Bit EIS1 / DPT 1.001	C, T
2	Operation mode Night(1 Bit)	1 Bit EIS1 / DPT 1.001	C, T
3	Operation mode Frost(1 Bit)	1 Bit EIS1 / DPT 1.001	C, T
4	Operation mode (1 Byte)	1 Byte / DPT 20.102	C, T

11.17 Media control, CD player

A CD player can be remotely controlled via the bus using the "Media control, CD player" application.

The symbols for "On/Off", "CD selection", "Player control" and "Volume" are shown first on the display. Via the push-button/rotary control element, the user can access a submenu ("CD selection", "Player control" and "Volume") or can switch directly on or off via a push-button operation.

In the submenu "Player control" the symbols for Start, Stop, Forward etc. are shown on the display. By turning the push-button/rotary control element, the user can select the desired function (focus) and trigger it with a push-button operation. The "CD selection" submenu functions in a similar way.

If the volume is to be regulated, a special volume symbol is shown on the display which signals the user that: a turn to the right increases the volume and a turn to the left reduces the volume. A feedback signal from the connected actuator can not be shown here.

Depending on the function, telegrams to the CD player control are sent out on the communication objects for "CD on/off", "CD selection", "CD play", "CD stop", "CD pause", "CD previous track", "CD next track", "CD volume".

In addition, the function can be temporarily blocked via an additional 1-bit "Enable" communication object.

Hint:

The function is practical only if a corresponding additional unit, such as the media box made by Coldwey, for CD player activation is used as receiver of the sent out telegrams.

Media control objects, CD player

No.	Object name	Data type	Flags
0	Enable	1 Bit EIS1 / DPT 1.001	C, W, U
1	CD On, Off	1 Bit EIS1 / DPT 1.001	C, W, T, U
2	CD Selection	1 Bit EIS1 / DPT 1.001	C, T
3	CD Play	1 Bit EIS1 / DPT 1.001	C, T
4	CD Stop	1 Bit EIS1 / DPT 1.001	C, T
5	CD Pause	1 Bit EIS1 / DPT 1.001	C, T
6	CD Previous track	1 Bit EIS1 / DPT 1.001	C, T
7	CD Next track	1 Bit EIS1 / DPT 1.001	C, T
8	CD Volume	4 Bit EIS2 / DPT 3.007	C, T

11.18 Media control, radio

A radio can be remotely controlled via the bus using the "Media control, radio" application.

The symbols for "On/Off", "Radio station selection" and "Volume" are shown first on the display. Via the push-button/rotary control element, the user can access a submenu ("Radio station selection" and "Volume") or can switch directly on or off via a push-button operation.

The stations that can be selected are listed in the "Radio station selection" submenu. By turning the push-button/rotary control element, the user can select the desired station (focus) and call it up via a push-button operation. If the volume is to be regulated, a special volume symbol is shown on the display which signals the user that: a turn to the right increases the volume and a turn to the left reduces the volume. A feedback signal from the connected actuator can not be shown here.

Depending on the function, telegrams for radio control are sent out on the communication objects for "Radio On/Off", "Station selection" and "Radio volume".

In addition, the function can be temporarily blocked via an additional 1-bit "Enable" communication object.

Hint:

The function is practical only if a corresponding actuator (audio actuator) for radio activation is used as receiver for the sent out telegrams.

Media control objects, radio

No.	Object name	Data type	Flags
0	Enable	1 Bit EIS1 / DPT 1.001	C, W, U
0	Radio On, Off	1 Bit EIS1 / DPT 1.001	C, W, T, U
0	Station selection	1 Bit EIS14 / DPT 5.010	C, T
0	Radio volume	4 Bit EIS2 / DPT 3.007	C, T

11.19 Media control, video player

A CD player can be remotely controlled via the bus using the "Media control CD player" application.

The symbols for "On/Off", "Player control" and "Volume" are shown first on the display. Via the push-button/rotary control element, the user can access a submenu ("Player control" and "Volume") or can switch directly on or off via a push-button operation.

In the submenu "Player control" the symbols for Start, Stop, Forward etc. are shown on the display. By turning the push-button/rotary control element, the user can select the desired function (focus) and trigger it with a push-button operation. If the volume is to be regulated, a special volume symbol is shown on the display which signals the user that: a turn to the right increases the volume and a turn to the left reduces the volume.

A feedback signal from the connected actuator can not be shown here.

Depending on the function, telegrams to the video player control are sent out for "Video on/off", "Video selection", "Video play", "Video stop", "Video pause", "Video rewind", "Video fast-forward", "Video volume". In addition, the function can be temporarily blocked via an additional 1-bit "Enable" communication object.

Hint:

The function is practical only when a corresponding actuator (video actuator) for video player activation is used as receiver for the sent out telegrams.

Media control objects, video player

No.	Object name	Data type	Flags
0	Enable	1 Bit EIS1 / DPT 1.001	C, T, U
1	Video On, Off	1 Bit EIS1 / DPT 1.001	C, W, T, U
2	Video Play	1 Bit EIS1 / DPT 1.001	C, T
3	Video Stop	1 Bit EIS1 / DPT 1.001	C, T
4	Video Pause	1 Bit EIS1 / DPT 1.001	C, T
5	Video Forward (Video Rewind)	1 Bit EIS1 / DPT 1.001	C, T
6	Video Rewind (Video Forward)	1 Bit EIS1 / DPT 1.001	C, T
7	Video Volume	4 Bit EIS2 / DPT 3.007	C, T

11.20 Short-time timer

Via the alarm or timer function there is the option of triggering an acoustic signal at a specific time or after expiration of an entered time.

The "short-time timer" application displays a timer function. There is the option here of triggering an acoustic signal via the internal speaker after expiration of an entered time. The time (up to 12 h 59 min) is set by the user via the push-button/rotary control element. After expiration of the set time, a signal tone is triggered on the unit which can be confirmed via the push-button/rotary control element.

The set "Value for timer start" (ON or OFF) is sent out via a 1-bit "Timer status" communication object at timer start. The set "Value for timer expiration" (ON or OFF) is sent out at timer expiration.

Short-time timer objects

No.	Object name	Data type	Flags
0	Adjusting (1 Bit)	1 Bit EIS7 / DPT 1.007	C, W, T, U
0	Adjusting (1 Byte)	1 Byte EIS6 / DPT 5.001	C, W, T, U
1	Moving (1 Bit)	1 Bit EIS7 / DPT 1.008	C, W, T, U
1	Moving (1 Byte)	1 Byte EIS6 / DPT 5.001	C, W, T, U

11.21 Weekly timer

With the "week timer" it is possible to call up defined switching times that are stored in the unit. Up to four different programs can be called up and edited by the user on the display via the push-button / rotary control element.

For the activation of different actuators, the size of the "Value" communication objects can be separately set for every individual program under the "Object type" parameter.

Up to four time blocks can be specified for each program. This means that four switching times (control times) to those predefined values are sent out on the associated communication object "Value".

For specifying the individual switching times the application uses the system time of the device. The current time can be synchronized in the device settings via the 3-byte "Time" communication object (see unit settings).

Weekly timer objects

No.	Object name	Data type	Flags
0	Absence	1 Bit EIS1 / DPT 1.001	C, W, T, U
1...4	Value 1 [2...4] (1 bit switching)	1 Bit EIS1 / DPT 1.001	C, T
1...4	Value 1 [2...4] (1 bit moving)	1 Bit EIS7 / DPT 1.008	C, T
1...4	Value 1 [2...4] (1 byte light scene number)	1 Byte / DPT 18.001	C, T
1...4	Value 1 [2...4] (1 Byte 0..100 %)	1 Byte EIS6 / DPT 5.001	C, T
1...4	Value 1 [2...4] (1 Byte 0..255)	1 Byte EIS14 / DPT 5.010	C, T
1...4	Value 1 [2...4] (2 Byte Float)	2 Byte EIS5 / DPT 9.xxx	C, T
1...4	Value 1 [2...4] (2 Byte Unsigned)	2 Byte EIS10 / DPT 7.001	C, T

11.22 Alarm clock

Alarm times (alarm clock times) can be defined with the "Alarm-clock" application. The times are set by the user with the push-button/rotary control element. When the set time is reached, a signal tone is triggered on the device which can be confirmed via the push-button/rotary control element.

When the alarm time has been reached, additional functions can be integrated into the alarm call function via a communication object. In addition, there is the option of sending out an advanced telegram, i.e. a telegram which is triggered before reaching the alarm time. For the activation of different actuators, the size of the "Switching" and "Advanced switching" communication objects is adjustable under the "Object type" parameter.

Alarm clock objects

No.	Object name	Data type	Flags
0	Acknowledgement	1 Bit EIS1 / DPT 1.001	C, W, U
1	Snooze	1 Bit EIS1 / DPT 1.001	C, W, U
2	Switching (1-bit switching)	1 Bit EIS1 / DPT 1.001	C, T
2	Switching (1-bit moving)	1 Bit EIS7 / DPT 1.008	C, T
2	Switching(1 Byte 0..100 %)	1 Byte EIS6 / DPT 5.001	C, T
2	Switching (scene call-up)	1 Byte / DPT 18.001	C, T
2	Switching(1 Byte 0..255)	1 Byte EIS14 / DPT 1.010	C, T
2	Switching(2 Byte Unsigned)	2 Byte EIS10 / DPT 7.001	C, T
2	Switching (relative temperature)	2 Byte EIS5 / DPT 9.001	C, T
2	Switching (absolute temperature)	2 Byte EIS5 / DPT 9.001	C, T
3	Switching, advanced (1-bit switching)	1 Bit EIS1 / DPT 1.001	C, T
3	Switching, advanced (1-bit moving)	1 Bit EIS7 / DPT 1.008	C, T
3	Switching, advanced(1 Byte 0..100 %)	1 Byte EIS6 / DPT 5.001	C, T
3	Switching, advanced (scene call-up)	1 Byte / DPT 18.001	C, T
3	Switching, advanced(1 Byte 0..255)	1 Byte EIS14 / DPT 5.010	C, T
3	Switching, advanced(2 Byte Unsigned)	2 Byte EIS10 / DPT 7.001	C, T
3	Switching, advanced (relative temperature)	2 Byte EIS5 / DPT 9.001	C, T
3	Switching, advanced (absolute temperature)	2 Byte EIS5 / DPT 9.001	C, T

11.23 Messages

Messages can be shown on the display and acoustically signaled over the internal loudspeaker. These can be predefined system messages such as "Storage medium was removed" or freely definable messages. A maximum of ten messages (message texts) can be created. The displayed message text is restricted to 48 characters.

Every message is assigned a priority (warning level) which determines the display of the message window. Information and alarm messages are indicated by a green bar. Warnings have a red bar and alarm messages appear completely red.

One or several active messages are shown in the display as soon as the user calls up the circuit menu. The circuit menu is only shown after all pending messages have been confirmed with "OK". The order in which the messages are issued is adjustable.

Should a message become active while a user is operating the device, this will be shown immediately. When the primary function is active, pending messages in the status line are shown by a blinking symbol. Depending on the message priority, a different symbol is used here. If several messages are active, the message symbol with the highest priority is always shown.

Message objects

No.	Object name	Data type	Flags
0	Message	1 Bit EIS1 / DPT 1.001	C, W, U
1	Acknowledgement	1 Bit EIS1 / DPT 1.001	C, W, T

11.24 Title text

The text/value display should be provided with a descriptive text that makes sense so that the user can recognise which text is displayed. For example, "Outside temperature", "Wind speed", "Bedroom window open", etc.

The descriptive text is shown in the display during scrolling and appears in the top left if the function is selected (focused).

Title text objects

No.	Function	Object name	Data type	Flags
0	Text / Value		1 Bit EIS1 / DPT 1.001	C, W, U
0	Text / Value		1 Byte EIS6 / DPT 5.001	C, W, U
0	Text / Value		1 Byte EIS14 / DPT 5.010	C, W, U
0	Text / Value		1 Byte EIS14 / DPT 6.010	C, W, U
0	Text / Value		2 Byte EIS5 / DPT 9.xxx	C, W, U
0	Text / Value		2 Byte EIS10 / DPT 8.018	C, W, U
0	Text / Value		2 Byte EIS10 / DPT 7.001	C, W, U
0	Text / Value		1 Bit EIS9 / DPT 14.xxx	C, W, U
0	Text / Value		1 Bit EIS6 / DPT 5.001	C, W, U
0	Text / Value		1 Byte EIS14 / DPT 5.010	C, W, U
0	Text / Value		1 Byte EIS14 / DPT 6.010	C, W, U
0	Text / Value		2 Byte EIS5 / DPT 9.xxx	C, W, U
0	Text / Value		2 Byte EIS10 / DPT 8.018	C, W, U
0	Text / Value		2 Byte EIS10 / DPT 7.001	C, W, U
0	Text / Value		1 Byte EIS9 / DPT 14.xxx	C, W, U

11.25 Unit blockage

The operation of the display from the circuit menu, or the call-up of individual functions, can be protected against unauthorised access by means of a PIN. Entering the correct pin allows the device to be operated.

If a function is protected by a PIN, a lock symbol is shown on the display in front of the function description.

Hint:

Only one PIN can be assigned to each unit. If a wrong PIN is entered, there is no limit to the number of times the entry can be repeated.

11.26 RTC settings

Default settings for the internal room temperature controller can be set with the "RTC settings" application. The room temperature controller can be used for "Heating", "Cooling" as well as for "Heating and Cooling". There is also the option of controlling fan coil actuators.

11.27 Sequence actuator settings

With the "Sequence actuator settings" application and the press of the push-button/rotary control element it is possible to consecutively send out multiple telegrams with different values in a predefined sequence via the same object.

The representation of a sequence on the display is based on the representation of a scene. In contrast to the "Scene", the "Sequence actuator settings" application has only one communication object on which up to twelve individual values are consecutively sent out in twelve firmly set times. The times can be freely set from 1 s to 12 h. The "Sequence actuator settings" application lends itself to controlling showrooms for example.

If sequences are configured, they are listed together with scenes under menu item "Scenes" and can be started from there. Values and delay times are edited under the "Scenes" menu item.

Via the "Quick run" function, the brightness values can be started up at an accelerated rate. The delay time then amounts to a constant 3 s from value to value.

Sequence actuator settings objects

No.	Object name	Data type	Flags
0	Enable	1 Bit EIS1 / DPT 1.001	C, W, T
1	Sequence value (1 Bit)	1 Bit EIS1 / DPT 1.001	C, T
1	Sequence value (1 Byte 0..100 %)	1 Byte EIS6 / DPT 5.001	C, T
1	Sequence value (1 Byte 0..255)	1 Byte EIS14 / DPT 5.010	C, T
1	Sequence value (1-byte light scene number)	1 Byte / DPT 18.001	C, T
1	Sequence value (2 Byte Float)	2 Byte EIS5 / DPT 9.xxx	C, T
1	Sequence value (2 Byte Unsigned)	2 Byte EIS10 / DPT 7.001	C, T
2	Sequence start-stop	1 Bit EIS1 / DPT 1.001	C, W, U
3	Sequence status	1 Bit EIS1 / DPT 1.001	C, T

11.28 Shutting actuator

With the "Shutting actuator" application the shutting actuator is activated (Flush-type switch actuator 2-gang).

It has two 1-bit communication objects "Move" and "Adjust". In addition, the Venetian blind can be moved to a defined position via the 1-byte communication objects "Position" and "Slats position".

The behaviour can be adjusted so that no undefined state arises during a bus voltage recovery.

There is also the option of additionally activating a 1-bit communication object "Status response". The shutting actuator can send out its current state over this.

Shutting actuator objects

No.	Object name	Data type	Flags
0	Move	1 Bit EIS7 / DPT 1.008	C, W
1	Adjust	1 Bit EIS7 / DPT 1.007	C, W
1	Stop	1 Bit / DPT 1.017	C, W
2	Position	1 Byte EIS5 / DPT 5.001	C, W
3	Slats position	1 Byte EIS5 / DPT 5.001	C, W
4	Wind alarm	1 Bit / DPT 1.005	C, W
5	Rain alarm	1 Bit / DPT 1.005	C, W
6	Frost alarm	1 Bit / DPT 1.005	C, W
7	Move status	1 Bit EIS7 / DPT 1.008	C, R, T
8	Position state	1 Byte EIS5 / DPT 5.001	C, R, T
9	Slats position status	1 Byte EIS5 / DPT 5.001	C, R, T

11.29 Switch actuator application

The flush-type switch actuator is activated with the "Switch actuator application" application.

For this the application has a 1-bit communication object "Switch object". Depending on the setting of the "Relay characteristics" parameter, the relay contact is opened or closed after receipt of an ON or OFF telegram.

The behaviour can be adjusted so that no undefined state arises after a bus voltage failure and subsequent return of voltage.

There is also the option of activating an additional 1-bit communication object "Status response". The switching actuator can send out its current state over this. Whether an ON or an OFF telegram is triggered during a closed or an opened relay contact depends on the setting of the "Relay characteristics" and "Invert status response" parameters.

Switch actuator application objects

No.	Object name	Data type	Flags
0	Switch object	1 Bit EIS1 / DPT 1.001	C, W
1	Status response signal	1 Bit EIS1 / DPT 1.001	C, T

11.30 Movement detector

The "Movement detector" application can trigger telegrams on the bus when a movement is detected in the detection range. Telegrams can also be sent on the bus when telegrams are received on the 1-bit communication object "External push-button input". This means that a device can be activated by additional KNX devices as if a movement was detected. The time for sending out a telegram depends especially on the operating mode that has been set. The movement detector has available the operating modes "Message", "Automatic switch-off", "Automatic switch-on" or "Automatic".

In the "Message" mode the movement detector is in the position to send telegrams cyclically on the "Start movement" 1-bit communication object.

In the "Automatic switch-off" mode the movement detector must be switched on manually via the receipt of an ON telegram on the "External push-button input" object. The device switches off after the set switch-off delay beginning from the most recent detection or manually.

In "Automatic switch-on" mode the movement detector switches on automatically when detecting a movement. It switches off at the receipt of an OFF telegram on the "External push-button input" object.

Note: The movement detector switches off automatically after 6 hours.

In the "Automatic" mode the movement detector switches on automatically when detecting a movement. It switches off after the specified switch-off delay beginning from the most recent detection or through the receipt of an OFF telegram on the "External push-button input" object. When switching off manually the detection of movement is suppressed for the parameterised pause time via the internal sensor.

The movement detector can be activated permanently via the "Switchover of external push-button input" 1-bit communication object. The function can, for example, be used during cleaning actions to cause all movement detectors to activate themselves even when no movement was detected.

If a movement detector works in an operating mode with switch-off delay, this can be adjusted during operation via a separate communication object. This would allow different switch-off delays to be used for mornings and for evenings.

The behaviour can be adjusted after the return of bus voltage so that no undefined state arises after a bus voltage failure and subsequent return of bus voltage.

The movement detector can be blocked via an enable object.

The movement detector can switch brightness-dependent or brightness-independent. The setting parameters can be used to adjust the threshold value of the light sensor. The brightness switching threshold can also be adjusted via communication objects via the bus.

Movement detector objects

No.	Object name	Data type	Flags
0	Enable	1 bit EIS 1 / DPT 1.001	C, W, U
1	Switch-off delay	2 byte / DPT 7.005	C, W, U
2	Extension unit input	1 bit EIS 1 / DPT 1.001	C, W, U
3	Input actuator status	1 bit EIS 1 / DPT 1.001	C, W, U
4	Detection independent of brightness	1 bit EIS 1 / DPT 1.001	C, W, U
5	External brightness	2 byte EIS 5 / DPT 9.004	C, W, U
6	External brightness threshold	2 byte EIS 5 / DPT 9.004	C, W, U
7	Internal brightness threshold	1 byte EIS 5 / DPT 9.004	C, W, U
8	LED output	1 bit EIS 1 / DPT 1.001	C, W, U
9	Switching movement	1 bit EIS 1 / DPT 1.001	C, T
9	Switching movement	1 byte EIS 5 / DPT 5.001	C, T
9	Switching movement	1 byte EIS 6 / DPT 5.010	C, T
10	Starting movement	1 byte EIS 1 / DPT 1.001	C, T
11	Switchover of external push-button input	1 bit EIS 1 / DPT 1.001	C, W, U
13	External push-button input	1 bit EIS 1 / DPT 1.001	C, W, U

11.31 LED function

With the "LED function" application, the LED of the rocker can be used for orientation lighting, for status indication or for function display. The LED can light up in different colours. The LED can also flash for alarm display and/or scene storage display.

LED function objects

No.	Object name	Data type	Flags
0	Status (1 Bit)	1 Bit EIS1 / DPT 1.001	C, W, U
0	Status (1 Byte 0..100 %)	1 Bit EIS6 / DPT 5.001	C, W, U
1	Day / Night mode (1 Bit)	1 Bit EIS1 / DPT 1.001	C, W, U
2	Proximity (1 Bit)	1 Bit EIS1 / DPT 1.001	C, W, U
3	Alarm (DPT_Alarm)	1 Bit / DPT_Alarm	C, W, U
4	Scene storage (DPT_Scene_Control)	1 Byte / DPT 18.001	C, W, U

11.32 Alarm function

If the alarm function is switched active, the LED can be made to flash (1 Hz) during the status or function display via a 1-bit "Alarm" communication object.

The LED will flash if an ON telegram is received on a 1-bit "Alarm" communication object. If the object receives an OFF telegram, the LED will no longer flash.

The LED always flashes in the same colour and brightness that was specified via the status function or function display.

The alarm function could, for example, be used to display a wind alarm to the user to let the user know that no blind operation is possible at that time. An additional application would be the signalling of an open door when the user would like to lower a roller blind.

Hint:

If the LED is currently serving as an orientation light, it will not flash. This also applies if it is switched to orientation lighting during flashing, i.e. the LED stops flashing immediately.

11.33 Light scene memory function

If the "Light scene memory function" is switched active, the LED can be made to flash (3 Hz) via a 1-bit communication object "Scene storage" during the status or function display.

If a scene storage telegram is received on the 1-byte communication object "Scene storage", the LED will blink for 3 s and then stop blinking automatically.

The LED always flashes in the same colour and brightness that is specified via the status function or function display.

Hint:

If the LED is currently serving as an orientation light, it will not blink. This also applies if orientation illumination is switched to during flashing.

11.34 Delay

Telegrams can be received via the "Input" object using the "Delay" application. The telegrams received are sent out on the "Output" object with a set delay time.

The object types for "Input" and "Output" can be collectively parameterised for different applications.

Delay objects

No.	Object name	Data type	Flags
0	Input (1 Bit)	1 Bit EIS1 / DPT 1.001	C, W
0	Input (1 Bit)	1 Bit EIS7 / DPT 1.008	C, W
0	Input (1 Bit)	1 Bit EIS7 / DPT 1.007	C, W
0	Input (1 Byte 0..100 %)	1 Byte EIS6 / DPT 5.001	C, W
0	Input (1 Byte 0..255)	1 Byte EIS14 / DPT 5.010	C, W
0	Input (2 Byte Float)	2 Byte EIS5 / DPT 9.xxx	C, W
0	Input (2 Byte Signed)	2 Byte EIS10 / DPT 8.001	C, W
0	Input (2 Byte Unsigned)	2 Byte EIS10 / DPT 7.001	C, W
0	Input (4 Byte Float)	4 Byte EIS9 / DPT 14.xxx	C, W
0	Input (4 Byte Signed)	4 Byte EIS11 / DPT 13.001	C, W
0	Input (4 Byte Unsigned)	4 Byte EIS11 / DPT 12.001	C, W
1	Output (1 Bit)	1 Bit EIS1 / DPT 1.001	C, T
1	Output (1 Bit)	1 Bit EIS7 / DPT 1.008	C, T
1	Output (1 Bit)	1 Bit EIS7 / DPT 1.007	C, T
1	Output (1 Byte 0..100 %)	1 Byte EIS6 / DPT 5.001	C, T
1	Output (1 Byte 0..255)	1 Byte EIS14 / DPT 5.010	C, T
1	Output (2 Byte Float)	2 Byte EIS5 / DPT 9.xxx	C, T
1	Output (2 Byte Signed)	2 Byte EIS10 / DPT 7.001	C, T
1	Output (2 Byte Unsigned)	2 Byte EIS10 / DPT 7.001	C, T
1	Output (4 Byte Float)	4 Byte EIS9 / DPT 14.xxx	C, T
1	Output (4 Byte Signed)	4 Byte EIS11 / DPT 13.001	C, T
1	Output (4 Byte Unsigned)	4 Byte EIS11 / DPT 12.001	C, T
2	Delay time (2 Byte)	2 Byte EIS10 / DPT 7.001	C, R, W

11.35 Staircase lighting

With the "Staircase lighting" application, switching telegrams or value telegrams can be provided with a light-on time. Depending on the parameterisation, the application shows different communication objects:

- a 1-bit object for input and output

If an ON telegram is received via the "Input/Output" object, the light-on time is started immediately. This can be a light-on time of 00:10 min to 88:45 min, which is adjustable in 0.1 s steps. After expiration of the light-on time, the "Input/Output" object sends an OFF telegram.

- two 1-bit objects for input and output
- two 1-byte objects for input and output

If a telegram is received via the "Input" object, the light-on time is started immediately and a telegram with the same value of the telegram received on the input is sent out on the "Output" object. This can be a light-on time of 00:10 min to 88:45 min, which is adjustable in 0.1 s steps. After expiration of the light-on time, the "Output" object sends out an OFF telegram (1-bit) or a telegram with the value "0" (1-byte).

Via two additional communication objects, it is possible to specify the light-on time and the switch-off prewarning time. The 2-byte values received are written to the memory of the device and are retained even after a bus power failure and subsequent return of voltage.

Staircase lighting objects

No.	Object name	Data type	Flags
0	Input (1 Bit)	1 Bit EIS1 / DPT 1.001	C, W
0	Input (1 Byte)	1 Bit EIS14 / DPT 5.010	C, W
0	Input_Output (1 Bit)	1 Bit EIS1 / DPT 1.001	C, W, T
1	Light-on time (2 Byte)	2 Byte EIS10 / DPT 7.001	C, R, W
2	Switch-off pre-warning	2 Byte EIS10 / DPT 7.001	C, R, W
3	Output (1 Bit)	1 Bit EIS1 / DPT 1.001	C, T
3	Output (1 Byte)	1 Bit EIS14 / DPT 5.010	C, T

11.36 Light scene actuator

With the "Light scene actuator" application, it is possible to call up scenes that are stored in the device via the receipt of a scene number on the 1-byte communication object "Scene call-up". A maximum of eight scenes with up to eight actuator objects can be created.

For triggering different actuators, the size of the actuator groups communication objects can be set under the "Actuator group type" parameter.

The user has the option of saving the scenes himself. A corresponding save telegram must be received for this (see the description of the individual parameters).

Light scene actuator objects

No.	Object name	Data type	Flags
0	Light scene call-up (1 Byte)	1 Byte / DPT18.001	C, W, U
1...10	Actuator group A [B...J] (1-bit switching)	1 Bit EIS1 / DPT 1.001	C, W, T, U
1...10	Actuator group A [B...J] (1-bit Venetian blind)	1 Bit EIS7 / DPT 1.008	C, W, T, U
1...10	Actuator group A [B...J] (1 Byte 0..100 %)	1 Byte EIS6 / DPT 5.001	C, W, T, U
1...10	Actuator group A [B...J] (1-byte light scene number)	1 Byte / DPT 18.001	C, W, T, U
1...10	Actuator group A [B...J] (Temperature value absolute)	2 Byte EIS5 / DPT 9.001	C, W, T, U
10...19	Enable scene 1 [Scene 2 ... Scene 10]	1 Bit EIS1 / DPT 1.001	C, W, T

11.37 Sequence

With the "Sequence " application it is possible to send out multiple telegrams with different values in a predefined sequence consecutively over the same object.

In contrast to the scene, the "Sequence" application has only one communication object on which up to twelve individual values are consecutively sent in twelve firmly set times. The times can be freely set from 1 s to 12 h. The "Sequence" application lends itself to controlling showrooms for example.

The function can be temporarily blocked via an enable object.

Sequence objects

No.	Object name	Data type	Flags
0	Sequence value (1-bit switching)	1 Bit EIS1 / DPT 1.001	C, W, T, U
0	Sequence value (1 Byte 0..100 %)	1 Byte EIS6 / DPT 5.001	C, W, T, U
0	Sequence value (1 Byte 0..255)	1 Byte EIS14 / DPT 5.010	C, W, T, U
0	Sequence value (1-byte light scene number)	1 Byte / DPT 18.001	C, W, T, U
0	Sequence value (2 Byte Float)	2 Byte EIS5 / DPT 9.xxx	C, W, T, U
0	Sequence value (2 Byte Unsigned)	2 Byte EIS10 / DPT 7.001	C, W, T, U
1	Sequence start	1 Bit EIS1 / DPT 1.001	C, W
2	Sequence status	1 Bit EIS1 / DPT 1.001	C, T
4	Enable	1 Bit EIS1 / DPT 1.001	C, W

11.38 Preset

The "Preset" application makes an input and output communication object available. At the receipt of a switching telegram on the 1-bit input object, a telegram is immediately sent out on the 1-byte output object. A preset percent value or, alternatively, a light scene number can be sent out.

Preset objects

No.	Object name	Data type	Flags
0	Input (1 Bit)	1 Bit EIS1 / DPT 1.001	C, W
0	Output (1 Byte 0..100 %)	1 Byte EIS6 / DPT 5.001	C, T
0	Output (1-byte light scene number)	1 Byte / DPT 18.001	C, T

11.39 Cyclic telegram

Via the "Cyclic telegram" application and after receipt of a telegram on the "Input" object, a telegram with the same volume is cyclically sent out on the "Cyclic output" object.

The object types for "Input" and "Output" can be collectively parameterised for the different applications.

The times for cyclic sending on the "Output" object are adjustable.

Via an additional "Enable" object, there is the option of temporarily blocking the function.

Cyclic telegram objects

No.	Object name	Data type	Flags
0	Input (1-bit switching)	1 Bit EIS1 / DPT 1.001	C, W
0	Input (1-bit alarm)	1 Bit EIS1 / DPT 1.001	C, W
0	Input (1 Byte 0..100 %)	1 Byte EIS6 / DPT 5.001	C, W
0	Input (1 Byte 0..255)	1 Byte EIS14 / DPT 5.010	C, W
0	Input (2 Byte Float)	2 Byte EIS5 / DPT 9.xxx	C, W
0	Input (2 Byte Signed)	2 Byte EIS10 / DPT 8.001	C, W
0	Input (2 Byte Unsigned)	2 Byte EIS10 / DPT 7.001	C, W
0	Input (2-byte temperature)	2 Byte EIS5 / DPT 9.001	C, W
0	Input (4 Byte Float)	4 Byte EIS9 / DPT 14.xxx	C, W
0	Input (4 Byte Signed)	4 Byte EIS11 / DPT 13.001	C, W
0	Input (4 Byte Unsigned)	4 Byte EIS11 / DPT 12.001	C, W
1	Output (1-bit switching)	1 Bit EIS1 / DPT 1.001	C, T
1	Output (1-bit alarm)	1 Bit EIS1 / DPT 1.001	C, T
1	Output (1 Byte 0..100 %)	1 Byte EIS6 / DPT 5.001	C, T
1	Output (1 Byte 0..255)	1 Byte EIS14 / DPT 5.010	C, T
1	Output (2 Byte Float)	2 Byte EIS5 / DPT 9.xxx	C, T
1	Output (2 Byte Signed)	2 Byte EIS10 / DPT 8.001	C, T
1	Output (2 Byte Unsigned)	2 Byte EIS10 / DPT 7.001	C, T
1	Output (2-byte temperature)	2 Byte EIS5 / DPT 9.001	C, T
1	Output (4 Byte Float)	4 Byte EIS9 / DPT 14.xxx	C, T
1	Output (4 Byte Signed)	4 Byte EIS11 / DPT 13.001	C, T
1	Output (4 Byte Unsigned)	4 Byte EIS11 / DPT 12.001	C, T
2	Enable	1 Bit EIS1 / DPT 1.001	C, W

11.40 Flashing

In order to trigger a flashing sequence on the output object, a telegram must be received on the input object beforehand. The "Flashing" parameter specifies whether the flashing sequence is started with an ON or an OFF telegram on the input object. Alternatively, the flashing sequence can also be started with a "Change of state", i.e. if the input signal switches from "0" to "1" or from "1" to "0".

Flashing objects

No.	Object name	Data type	Flags
0	Input	1 Bit EIS1 / DPT 1.001	C, W
1	Output	1 Bit EIS1 / DPT 1.001	C, T

11.41 Logic

Logic objects

No.	Object name	Data type	Flags
0	Output (1 Bit)	1 Bit EIS1 / DPT 1.001	C, W, T
0	Output (1 Byte)	1 Byte EIS14 / DPT 5.010	C, W, T
1	Input 1 (1 Bit)	1 Bit EIS1 / DPT 1.001	C, W, U
1	Input 1 (1 Byte)	1 Byte EIS14 / DPT 5.010	C, W, U
2	Input 2 (1 Bit)	1 Bit EIS1 / DPT 1.001	C, W, U
2	Input 2 (1 Byte)	1 Byte EIS14 / DPT 5.010	C, W, U
3	Input 3 (1 Bit)	1 Bit EIS1 / DPT 1.001	C, W, U
3	Input 3 (1 Byte)	1 Byte EIS14 / DPT 5.010	C, W, U
4	Input 4 (1 Bit)	1 Bit EIS1 / DPT 1.001	C, W, U
4	Input 4 (1 Byte)	1 Byte EIS14 / DPT 5.010	C, W, U
5	Input 5 (1 Bit)	1 Bit EIS1 / DPT 1.001	C, W, U
5	Input 5 (1 Byte)	1 Byte EIS14 / DPT 5.010	C, W, U
6	Input 6 (1 Bit)	1 Bit EIS1 / DPT 1.001	C, W, U
6	Input 6 (1 Byte)	1 Byte EIS14 / DPT 5.010	C, W, U
7	Input 7 (1 Bit)	1 Bit EIS1 / DPT 1.001	C, W, U
7	Input 7 (1 Byte)	1 Byte EIS14 / DPT 5.010	C, W, U
8	Input 8 (1 Bit)	1 Bit EIS1 / DPT 1.001	C, W, U
8	Input 8 (1 Byte)	1 Byte EIS14 / DPT 5.010	C, W, U
9	Input 9 (1 Bit)	1 Bit EIS1 / DPT 1.001	C, W, U
9	Input 9 (1 Byte)	1 Byte EIS14 / DPT 5.010	C, W, U
10	Input 10 (1 Bit)	1 Bit EIS1 / DPT 1.001	C, W, U
10	Input 10 (1 Byte)	1 Byte EIS14 / DPT 5.010	C, W, U

11.42 Gate

The "Gate" application allows specific signals to be filtered and the signal flow to be temporarily blocked. The function has three communication objects: "Control input", "Input" and "Output".

The input or output object can assume different sizes.

The bit size can be freely assigned with the "Not assigned" setting. This means that the first internal or external group address/action that is assigned and already connected to some other communication object will specify the size.

The control can occur from "Input to output" or also from "Output to input", provided the control input allows this. Enabling via the control input can occur via an ON or an OFF telegram.

If, for example, the "Control input" setting is set to "ON telegram", only telegrams from the input are transmitted to the output, if prior to this the control input has received an ON telegram.

It is also possible to block signals via the "Filter function" setting. Either "nothing is filtered out" or the signal "ON is filtered out" or the signal "OFF is filtered out". This function is always necessary, for example, when only the ON telegram is interesting for a sensor and the sensor does not offer any filter function in its application program.

Gate objects

No.	Object name	Data type	Flags
0	Input	-	C, W, T
1	Output	-	C, W, T
2	Control input	1 Bit EIS1 / DPT 1.001	C, W

11.43 Min/Max value transducer

Up to eight input values can be compared with each other using the "Min/max value transducer" application. The application can output the highest input value, the smallest input value or the average of all input values on the output.

The size of the input objects, and with it also the size of the output object can be adapted for the most diverse applications.

You can select from the following object types:

- 1-byte 0..100 %, for comparison of percent values
- 1-byte 0..255, for the comparison of decimal values between 0 and 255
- 2-byte float, for the comparison of 2-byte floating point values (physical values such as temperature, brightness value etc.)
- 2-byte signed, for the comparison of decimal values between -32,768 and +32,767
- 2-byte unsigned, for the comparison of decimal values between 0 and 65,535
- 4-byte float, for the comparison of 4-byte floating point values (physical values such as acceleration, electrical current, work etc.)
- 4-byte signed, for the comparison of decimal values between -2,147,483,648 and 2,147,483,647
- 4-byte unsigned, for the comparison of decimal values between 0 and 4,294,967,295

Hint:

With whole numbers the average value is rounded.

Min/Max value transducer objects

No.	Object name	Data type	Flags
0	Output (1 Byte 0..100 %)	1 Byte EIS6 / DPT 5.001	C, T
0	Output (1 Byte 0..255)	1 Byte EIS14 / DPT 5.010	C, T
0	Output (2 Byte Float)	2 Byte EIS5 / DPT 9.xxx	C, T
0	Output (2 Byte Signed)	2 Byte EIS10 / DPT 8.001	C, T
0	Output (2 Byte Unsigned)	2 Byte EIS10 / DPT 7.001	C, T
0	Output (4 Byte Float)	4 Byte EIS9 / DPT 14.xxx	C, T
0	Output (4 Byte Signed)	4 Byte EIS11 / DPT 13.001	C, T
0	Output (4 Byte Unsigned)	4 Byte EIS11 / DPT 12.001	C, T
1...10	Input 1 [2...10] (1 Byte 0..100 %)	1 Byte EIS6 / DPT 5.001	C, W
1...10	Input 1 [2...10] (1 Byte 0..255)	1 Byte EIS14 / DPT 5.010	C, W
1...10	Input 1 [2...10] (2 Byte Float)	2 Byte EIS5 / DPT 9.xxx	C, W
1...10	Input 1 [2...10] (2 Byte Signed)	2 Byte EIS10 / DPT 8.001	C, W
1...10	Input 1 (2 Byte Unsigned)	2 Byte EIS10 / DPT 7.001	C, W
1...10	Input 1 [2...10] (4 Byte Float)	4 Byte EIS9 / DPT 14.xxx	C, W
1...10	Input 1 [2...10] (4 Byte Signed)	4 Byte EIS11 / DPT 13.001	C, W
1...10	Input 1 [2...10] (4 Byte Unsigned)	4 Byte EIS11 / DPT 12.001	C, W

11.44 Threshold value / hysteresis

With the "Threshold value / Hysteresis" application, value telegrams can be received on an input communication object and compared with threshold values specified in the device.

Predefined values are sent out on the communication "Output" communication object if the upper or lower thresholds are exceeded. The size of the object can be adjusted for different applications.

The function can be temporarily blocked via an enable object.

If the value of the lower threshold lies above the value for the upper threshold, the function is not executed.

Threshold value / hysteresis objects

No.	Object name	Data type	Flags
0	Input (1 Byte 0..100 %)	1 Byte EIS6 / DPT 5.001	C, W
0	Input (1 Byte 0..255)	1 Byte EIS14 / DPT 5.010	C, W
0	Input (2 Byte Float)	2 Byte EIS5 / DPT 9.xxx	C, W
0	Input (2 Byte Signed)	2 Byte EIS10 / DPT 8.001	C, W
0	Input (2 Byte Unsigned)	2 Byte EIS10 / DPT 7.001	C, W
0	Input (4 Byte Float)	4 Byte EIS9 / DPT 14.xxx	C, W
0	Input (4 Byte Signed)	4 Byte EIS11 / DPT 12.001	C, W
0	Input (4 Byte Unsigned)	4 Byte EIS11 / DPT 13.001	C, W
1	Output (1 Bit)	1 Bit EIS1 / DPT 1.001	C, T
1	Output (1 Byte 0..100 %)	1 Byte EIS6 / DPT 5.001	C, T
1	Output (1 Byte 0..255)	1 Byte EIS14 / DPT 5.010	C, T
2	Enable	1 Bit EIS1 / DPT 1.001	C, W

11.45 PWM inverter

With the "PWM inverter" application, a 1-byte input signal can be converted to a 1-bit signal or a 1-byte signal via an equivalent pulse-width modulation. This function is required, for instance, if a room temperature controller issues a constant control value that controls a switching heating actuator (for electrothermal actuating drives).

The function of the 1-byte sized activation is required if the room temperature controller can only send out constant control values or a constant control value is required for other functions (such as central supply line temperature control).

There is the option of activating a force-position. The force-position is used for certain events such as the opening of a window or for moving a heating actuator that is to be activated to a specific position for the dew point alarm.

If "Alert" is activated, the additional communication object "Fault" is available. A fault will then occur if the "Input" object has received no further telegram within a certain period of time. Possible reasons for this could be, for example, that the associated room temperature controller fails or that during a cross-line function the telegrams no longer pass the coupler. In this case an ON telegram is sent out on the "Fault" communication object and the "Input" object assumes the "Value for fault".

An additional "Enable" object provides the option of temporarily blocking the function.

PWM transducer objects

No.	Object name	Data type	Flags
0	Input (1 Byte)	1 Bit EIS1 / DPT 1.001	C, W
1	Output (1 Bit)	1 Bit EIS1 / DPT 1.001	C, T
1	Output (1 Byte 0..100 %)	1 Byte EIS6 / DPT 5.001	C, T
2	Enable	1 Bit EIS1 / DPT 1.001	C, W
3	Fault	1 Bit EIS1 / DPT 1.001	C, T
4	Force-position	1 Bit EIS1 / DPT 1.001	C, W

11.46 Priority

The "Priority" application has 3 communication objects, a 1-bit object "Switch input", a 2-bit object "Input priority" and a 1-bit object "Output". The telegrams received on the "Switch input" are transferred to the "Output" depending on the state of the "Input priority" object.

The 2-bit object "Input priority" can receive and differentiate between four different values (0, 1, 2 and 3). Here, the "Output" object is positively driven. Three different states are differentiated:

- "Input priority" has value "3": the value that is present on "Switch input" has no meaning. The "Output" is switched to positively driven and has the value "1".
- "Input priority" has the value "2". The value that is present on "Switch input" has no meaning. The "Output" is switched off positively driven and has the value "0".
- "Input priority" has the value "1" or "0". The "Output" is not positively driven. The "Switch input" is linked to the status bit of the priority object OR and transferred to the "Output".

During a positive drive, changes of the "Switch input" object are saved, even if the current state on the "Output" object does not immediately change through this. If the positive drive is terminated, a telegram transmission on the "Output" occurs according to the current value of the "Switch input" object.

Priority objects

No.	Object name	Data type	Flags
0	Switch input	1 Bit EIS1 / DPT 1.001	C, W
1	Priority input	2 Bit EIS8 / DPT 2.001	C, W
2	Output	1 Bit EIS1 / DPT 1.001	C, T

12 Description of applications/parameters for room temperature control 6351/08-825 + 6344-101 [from update version 0.1.6.0]

12.1 Application "RTC"

12.1.1 General - Device function

Options:	Single device
	Master device
	Slave device

- *Single device*: The device is used singly in a room as room temperature controller.
- *Master device*: At least two room temperature controllers are located in one room. One device is to be set up as a master device, while the others are to be programmed as slave devices / temperature sensors. The master device is to be linked to the slave devices using the appropriately labelled communication objects. The master device regulates the temperature.
- *Slave device/temperature sensor*: At least two room temperature controllers are located in one room. One device is to be set up as a master device, while the others are to be programmed as slave devices / temperature sensors. The slave devices are to be linked to the master device with the appropriately labelled communication objects. The slave device serves the room temperature control functions of the master.

12.1.2 General - Control function

Options:	Heating
	Heating with additional stage
	Cooling
	Cooling with additional stage
	Heating and cooling
	Heating and cooling with additional stage

- *Heating*: For operating a heat-based automatic single-room control. The temperature is regulated to the setpoint value defined in the parameter. The "Controller type" and "Heating type" can be programmed for optimal control.
- *Heating with additional stage*: In addition to the control function described under heating, the additional stage enables the activation of an additional heating circuit. This type of additional stage is used, for example, to quickly heat up a bathroom with floor heating via a heated towel rack.
- *Cooling*: For operating a cooling-based automatic single-room control. The temperature is regulated to the setpoint value defined in the parameter. The "Controller type" and "Cooling type" can be programmed for optimal control.
- *Cooling with additional stage*: In addition to the control function described under cooling, the additional stage enables the activation of an additional cooling device. This type of additional stage is used, for example, to quickly cool a room via an added cooling device.
- *Heating and cooling*: For operating a two-wire or four-wire system used to heat or cool a room. Switching between heating and cooling takes place using a central switch (two-wire system) or is carried out manually and / or automatically via the single room temperature controller (four-wire system).

- *Heating and cooling* with an additional stage: In addition to the heating and cooling functions, one additional stage each with an autonomous controller type can be programmed.



Note

This parameter is only available if the "Device function" parameter is set on "Single device" or "Master device".

12.1.3 General - Operating mode after reset

Options:	Comfort
	Standby
	Eco mode
	Cooling with additional stage
	Frost/heat protection

After a reset the device will run in the operating mode after a restart until a new operating mode is set as the result of device operation or by communication objects, as the case may be. This operating mode should be defined during the planning phase. An improperly defined operating mode can result in a loss of comfort or increased energy consumption.

- *Comfort*: If the room temperature is not automatically lowered and the room is therefore controlled independent of its use.
- *Standby*: If the room is controlled automatically, e.g. by a presence detector, as a function of its use.
- *Eco mode*: If the room is controlled automatically or manually as a function of its use.
- *Frost/heat protection*: If only the building protection function is necessary in the room after a reset.



Note

This parameter is only available if the "Device function" parameter is set on "Single device" or "Master device".

12.1.4 General - Additional functions

Options:	No
	Yes

- This parameter enables additional functions and communication objects, e.g. window contact and presence detector.

12.1.5 General - Send cyclic "In operation" (min)

Options:	Setting option between 5 - 3000 minutes
----------	---

- The "In operation" communication object serves to inform that the controller still operates. Value "1" is sent cyclic. This parameter is used to set the cycle for sending. If the cyclic telegram fails, the function of the device is faulty and the air-conditioning of the room can be maintained with a forced operation. However, for this the system and/or actuator must have "Forced operation" function.



Note

This parameter is only available if the "Additional function" parameter is set to "Yes".

12.1.6 Heating control



Note

Only available when the "Device function" parameter is set on either "Single device" or "Master device" and the control function parameter is set on either "Heating", "Heating with additional stage", "Heating and cooling" or "Heating and cooling with additional stages".

12.1.7 Heating control - Control value type

Options:	2-point 1 bit, Off/On
	2-point 1 byte, (0/100%)
	PI continuous, 0-100%
	PI PWM, On/Off
	Fan coil

The actuation of the control valve is determined by the selection of the controller type.

- *2-Point 1 Bit, Off/On*: The 2-point control is the simplest type of control. The controller switches on when the room temperature drops below a certain level (setpoint temperature value minus hysteresis) and switches off when a particular value (setpoint temperature value plus hysteresis) is exceeded. The switch-on and switch-off commands are transmitted as 1-bit commands.
- *2-Point 1 Byte, 0/100%*: This is another two-point control as described above. In this case, however, the switch-on and switch-off commands are transmitted as 1-byte values (0% / 100%).
- *PI continuous, 0-100%*: The PI controller adjusts its output value between 0% and 100% to match the difference between the actual value and the setpoint value and enables a precise regulation of the room temperature to the setpoint value. It sends the control value to the bus as a 1-byte value (0% - 100%). To reduce the bus load, the control value is only transmitted if it has changed by a predefined percentage in relation to the previous sent value. The control value can also be transmitted cyclically.
- *PI PWM, On/Off*: This also is a PI controller. Here, the output is a 1-bit command. For this to occur, the calculated control value is converted into a pulse-interval signal.
- *Fan coil*: The fan coil controller operates like the PI continuous controller. In addition, it allows the separate activation of the fan in the fan coil unit (e.g. fan speed levels 1 - 3).

12.1.8 Heating control - Heating type

Options:	PI continuous, 0 – 100% and PI PWM, On/Off: <ul style="list-style-type: none">▪ Area (e.g. floor heating) 4°C 200 min▪ Convector (e.g. heater) 1.5°C 100 min▪ Free configuration
	Fan coil: <ul style="list-style-type: none">▪ Fan coil 4°C 90 min▪ Free configuration

Multiple heating types (panel heating, convector heating or fan coil) with preset parameters are available to the user.

- If the required heating type is not available, individual parameters can be specified in free configuration.



Note

This parameter is only available when "Control value type" parameter is set either on "PI continuous, 0 – 100%", "PI PWM, On/Off" or "Fan coil".

12.1.9 Heating control - P-component (x 0.1°C)

Options:	Setting option between 10 - 100
----------	---------------------------------

The P-component refers to the proportional band of a control. It fluctuates around the setpoint value and can be used to influence control speed with a PI controller. The smaller the setpoint, the faster it reacts to the control. However, to avoid the risk of an overshoot, this value should not be set too low. A P-component from 0.1 to 25.5 K can be set.



Note

This parameter is only available when "Control value type" parameter is set either on "PI continuous, 0 – 100%", "PI PWM, On/Off" or "Fan coil". In addition, the "Heating type" parameter must be set on "Free configuration".

12.1.10 Heating control - I-component (min.)

Options:	Setting option between 0 - 255
----------	--------------------------------

The I-component refers to the reset time of a control. The integral component has the effect of moving the room temperature slowly toward, and ultimately reaching, the setpoint value. Depending on the type of system used, the reset time has to have different values. In general, the more inactive the overall system, the greater the reset time.



Note

This parameter is only available when "Control value type" parameter is set either on "PI continuous, 0 – 100%", "PI PWM, On/Off" or "Fan coil". In addition, the "Heating type" parameter must be set on "Free configuration".

12.1.11 Heating control - Extended settings

Options:	No
	Yes

- This parameter enables additional functions and communication objects, e.g. "Basic stage heating".

12.1.12 Basic stage heating



Note

Only available when the "Extended settings" parameter under "Heating control" is set on "Yes".

12.1.13 Basic stage heating - Status object heating

Options:	No
	Yes

- This parameter enables the "Status heating" communication object.

12.1.14 Basic stage heating - Mode of the control value

Options:	Normal
	Inverse

The mode of the control value can be used to adapt the control value to de-energised opened (normal) or de-energised closed (inverse) valves.

- *Normal*: Value 0 means "Valve closed".
- *Inverse*: Value 0 means "Valve open".

12.1.15 Basic stage heating - Hysteresis (x 0.1°C)

Options:	Setting option between 3 - 255
----------	--------------------------------

The hysteresis of the two-point controller specifies the fluctuation range of the controller around the setpoint value. The lower switching point is located at "Setpoint value minus hysteresis" and the upper point is at "Setpoint value plus hysteresis".



Note

This parameter is only available when the "Control value type" parameter is set either on "2-point 1 Bit, Off/On" or "2-point 1 Byte, 0/100%".

12.1.16 Basic stage heating - Control value difference for sending of heating control value

Options:	2 %
	5 %
	10 %
	Send cyclic only

The control values of the 0 - 100% PI continuous controller are not transmitted after every calculation. Instead, they are transmitted when the calculation results in a value that is different enough to the previous sent value to make a transmission meaningful. This value difference can be entered here.



Note

This parameter is only available when "Control value type" parameter is set either on "PI continuous, 0 – 100%", "PI PWM, On/Off" or "Fan coil".

12.1.17 Basic stage heating - Cyclic sending of the control value (min)

Options:	Setting option between 1 - 60 minutes
----------	---------------------------------------

The current control value used by the device can be cyclically transmitted to the bus.



Note

This parameter is only available when the "Control value type" parameter is set either on "2-point 1 Bit, Off/On", "2-point 1 Byte, 0/100%", "PI continuous, 0-100%" or "Fan coil".

12.1.18 Basic stage heating - PWM cycle heating (min)

Options: Setting option between 1 - 60 minutes

In PI PWM, On/off the control value percentage values are converted into a pulse-interval signal. This means that a selected PWM cycle will be divided into an on-phase and an off-phase based on the control value. Accordingly, a control value output of 33% in a PWM cycle of 15 min. results in an "On-phase" of five minutes and an "Off-phase" of 10 min. The time for a PWM cycle can be specified here.



Note

This parameter is only available when the "Control value type" parameter is set on "PI PWM, On/Off".

12.1.19 Basic stage heating - Maximum control value (0 - 255)

Options: Setting option between 0 - 255

The maximum control value of the PI controller defines the maximum value outputted by the controller. If a maximum value under 255 is chosen, the value will not be exceeded, even if the controller calculates a higher control value.



Note

This parameter is only available when "Control value type" parameter is set either on "PI continuous, 0 – 100%", "PI PWM, On/Off" or "Fan coil".

12.1.20 Basic stage heating - Minimum control value for basic load (0 to 255)

Options: Setting option between 0 - 255

The minimum control value of the PI controller defines the minimum value output by the controller. If a minimum value greater than zero is chosen, the controller will not output a lower value, even if it calculates a value that is lower. This parameter can be used to set a basic load, e.g. for operating floor heating. Even if the controller calculates the control value zero, a heating medium will flow through the floor heating system to prevent the floor from cooling down. Under "Settings of basic load", it is also possible to define whether this basic load will be permanently active or whether it will be switched by the "Basic load" object.



Note

This parameter is only available when "Control value type" parameter is set either on "PI continuous, 0 – 100%", "PI PWM, On/Off" or "Fan coil".

12.1.21 Control of additional heating stage



Note

Only available when the "Device function" parameter is set on either "Single device" or "Master device" and the control function parameter is set on either "Heating with additional stage" or "Heating and cooling with additional stages".

12.1.22 Control of additional heating stage - Control value type

Options:	2-point 1 bit, Off/On
	2-point 1 byte, (0/100%)
	PI continuous, 0-100%
	PI PWM, On/Off
	Fan coil

The actuation of the control valve is determined by the selection of the controller type.

- *2-Point 1 Bit, Off/On*: The 2-point control is the simplest type of control. The controller switches on when the room temperature drops below a certain level (setpoint temperature value minus hysteresis) and switches off when a particular value (setpoint temperature value plus hysteresis) is exceeded. The switch-on and switch-off commands are transmitted as 1-bit commands.
- *2-Point 1 Byte, 0/100%*: This is another two-point control as described above. In this case, however, the switch-on and switch-off commands are transmitted as 1-byte values (0% / 100%).
- *PI continuous, 0-100%*: The PI controller adjusts its output value between 0% and 100% to match the difference between the actual value and the setpoint value and enables a precise regulation of the room temperature to the setpoint value. It sends the control value to the bus as a 1-byte value (0% - 100%). To reduce the bus load, the control value is only transmitted if it has changed by a predefined percentage in relation to the previous sent value. The control value can also be transmitted cyclically.
- *PI PWM, On/Off*: This also is a PI controller. Here, the output is a 1-bit command. For this to occur, the calculated control value is converted into a pulse-interval signal.
- *Fan coil*: The fan coil controller operates like the PI continuous controller. In addition, it allows the separate activation of the fan in the fan coil unit (e.g. fan speed levels 1 - 3).

12.1.23 Control of additional heating stage - Additional heating type

Options:	PI continuous, 0 – 100% and PI PWM, On/Off: <ul style="list-style-type: none">▪ Area (e.g. floor heating) 4°C 200 min▪ Convector (e.g. heater) 1.5°C 100 min▪ Free configuration
	Fan coil: <ul style="list-style-type: none">▪ Fan coil 4°C 90 min▪ Free configuration

Multiple heating types (panel heating, convector heating or fan coil) with preset parameters are available to the user.

- If the required heating type is not available, individual parameters can be specified in free configuration.



Note

This parameter is only available when "Control value type" parameter is set either on "PI continuous, 0 – 100%", "PI PWM, On/Off" or "Fan coil".

12.1.24 Control of additional heating stage - P-component (x 0.1°C)

Options:	Setting option between 10 - 100
----------	---------------------------------

The P-component refers to the proportional band of a control. It fluctuates around the setpoint value and can be used to influence control speed with a PI controller. The smaller the setpoint, the faster it reacts to the control. However, to avoid the risk of an overshoot, this value should not be set too low. A P-component from 0.1 to 25.5 K can be set.



Note

This parameter is only available when "Control value type" parameter is set either on "PI continuous, 0 – 100%", "PI PWM, On/Off" or "Fan coil". In addition, the "Additional heating type" parameter must be set on "Free configuration".

12.1.25 Control of additional heating stage - P-component (min)

Options:	Setting option between 0 - 255
----------	--------------------------------

The I-component refers to the reset time of a control. The integral component has the effect of moving the room temperature slowly toward, and ultimately reaching, the setpoint value. Depending on the type of system used, the reset time has to have different values. In general, the more inactive the overall system, the greater the reset time.



Note

This parameter is only available when "Control value type" parameter is set either on "PI continuous, 0 – 100%", "PI PWM, On/Off" or "Fan coil". In addition, the "Additional heating type" parameter must be set on "Free configuration".

12.1.26 Control of additional heating stage - Temperature difference to basic stage (x 0.1°C)

Options:	Setting option between 0 - 255
----------	--------------------------------

The setpoint temperature of the additional stage is defined as a function of the current setpoint temperature of the base stage and is expressed as a difference. The value represents the setpoint value starting at which the additional stage will operate.

12.1.27 Control of additional heating stage - Extended settings

Options:	No
	Yes

This parameter enables additional functions and communication objects, e.g. "Additional heating stage".

12.1.28 Additional heating stage



Note

Only available when the "Extended settings" parameter under "Control of additional heating stage" is set on "Yes".

12.1.29 Additional heating stage - Mode of the control value

Options:	Normal
	Inverse

The mode of the control value can be used to adapt the control value to de-energised opened (normal) or de-energised closed (inverse) valves.

- *Normal*: Value 0 means "Valve closed".
- *Inverse*: Value 0 means "Valve open".

12.1.30 Additional heating stage - Hysteresis (x 0.1°C)

Options:	Setting option between 3 - 255
----------	--------------------------------

The hysteresis of the two-point controller specifies the fluctuation range of the controller around the setpoint value. The lower switching point is located at "Setpoint value minus hysteresis" and the upper point is at "Setpoint value plus hysteresis".



Note

This parameter is only available when the "Control value type" parameter is set either on "2-point 1 Bit, Off/On" or "2-point 1 Byte, 0/100%".

12.1.31 Additional heating stage - Control value difference for sending of heating control value

Options:	2 %
	5 %
	10 %
	Send cyclic only

The control values of the 0 - 100% PI continuous controller are not transmitted after every calculation. Instead, they are transmitted when the calculation results in a value that is different enough to the previous sent value to make a transmission meaningful. This value difference can be entered here.



Note

This parameter is only available when "Control value type" parameter is set either on "PI continuous, 0 – 100%", "PI PWM, On/Off" or "Fan coil".

12.1.32 Additional heating stage - Cyclic sending of the control value (min)

Options: Setting option between 1 - 60 minutes

The current control value used by the device can be cyclically transmitted to the bus.



Note

This parameter is only available when the "Control value type" parameter is set either on "2-point 1 Bit, Off/On", "2-point 1 Byte, 0/100%", "PI continuous, 0-100%" or "Fan coil".

Additional heating stage - Maximum control value (0 - 255)

Options: Setting option between 0 - 255

The maximum control value of the PI controller defines the maximum value outputted by the controller. If a maximum value under 255 is chosen, the value will not be exceeded, even if the controller calculates a higher control value.



Note

This parameter is only available when "Control value type" parameter is set either on "PI continuous, 0 – 100%", "PI PWM, On/Off" or "Fan coil".

12.1.33 Additional heating stage - Minimum control value for basic load (0 - 255)

Options: Setting option between 0 - 255

The minimum control value of the PI controller defines the minimum value output by the controller. If a minimum value greater than zero is chosen, the controller will not output a lower value, even if it calculates a value that is lower. This parameter can be used to set a basic load, e.g. for operating floor heating. Even if the controller calculates the control value zero, a heating medium will flow through the floor heating system to prevent the floor from cooling down. Under "Settings of basic load", it is also possible to define whether this basic load will be permanently active or whether it will be switched by the "Basic load" object.



Note

This parameter is only available when "Control value type" parameter is set either on "PI continuous, 0 – 100%", "PI PWM, On/Off" or "Fan coil".

12.1.34 Cooling control



Note

Only available when the "Device function" parameter is set on either "Single device" or "Master device" and the control function parameter is set on either "Cooling", "Cooling with additional stage", "Heating and cooling" or "Heating and cooling with additional stages".

12.1.35 Cooling control - Control value type

Options:	2-point 1 bit, Off/On
	2-point 1 byte, (0/100%)
	PI continuous, 0-100%
	PI PWM, On/Off
	Fan coil

The actuation of the control valve is determined by the selection of the controller type.

- *2-Point 1 Bit, Off/On*: The 2-point control is the simplest type of control. The controller switches on when the room temperature drops below a certain level (setpoint temperature value minus hysteresis) and switches off when a particular value (setpoint temperature value plus hysteresis) is exceeded. The switch-on and switch-off commands are transmitted as 1-bit commands.
- *2-Point 1 Byte, 0/100%*: This is another two-point control as described above. In this case, however, the switch-on and switch-off commands are transmitted as 1-byte values (0% / 100%).
- *PI continuous, 0-100%*: The PI controller adjusts its output value between 0% and 100% to match the difference between the actual value and the setpoint value and enables a precise regulation of the room temperature to the setpoint value. It sends the control value to the bus as a 1-byte value (0% - 100%). To reduce the bus load, the control value is only transmitted if it has changed by a predefined percentage in relation to the previous sent value. The control value can also be transmitted cyclically.
- *PI PWM, On/Off*: This also is a PI controller. Here, the output is a 1-bit command. For this to occur, the calculated control value is converted into a pulse-interval signal.
- *Fan coil*: The fan coil controller operates like the PI continuous controller. In addition, it allows the separate activation of the fan in the fan coil unit (e.g. fan speed levels 1 - 3).

12.1.36 Cooling control - Cooling type

Options:	PI continuous, 0 – 100% and PI PWM, On/Off: <ul style="list-style-type: none">▪ Area (e.g. cooling ceiling) 5°C 240 min▪ Free configuration
	Fan coil: <ul style="list-style-type: none">▪ Fan coil 4°C 90 min▪ Free configuration

Two cooling types (area or fan coil) with preset parameters are available to the user.

If the required cooling type is not available, individual parameters can be specified in free configuration.



Note

This parameter is only available when "Control value type" parameter is set either on "PI continuous, 0 – 100%", "PI PWM, On/Off" or "Fan coil".

12.1.37 Cooling control - P-component (x 0.1°C)

Options:	Setting option between 10 - 100
----------	---------------------------------

The P-component refers to the proportional band of a control. It fluctuates around the setpoint value and can be used to influence control speed with a PI controller. The smaller the setpoint, the faster it reacts to the control. However, to avoid the risk of an overshoot, this value should not be set too low. A P-component from 0.1 to 25.5 K can be set.



Note

This parameter is only available when "Control value type" parameter is set either on "PI continuous, 0 – 100%", "PI PWM, On/Off" or "Fan coil". In addition, the "Cooling type" parameter must be set on "Free configuration".

12.1.38 Cooling control - I-component (min.)

Options:	Setting option between 0 - 255
----------	--------------------------------

The I-component refers to the reset time of a control. The integral component has the effect of moving the room temperature slowly toward, and ultimately reaching, the setpoint value. Depending on the type of system used, the reset time has to have different values. In general, the more inactive the overall system, the greater the reset time.



Note

This parameter is only available when "Control value type" parameter is set either on "PI continuous, 0 – 100%", "PI PWM, On/Off" or "Fan coil". In addition, the "Cooling type" parameter must be set on "Free configuration".

12.1.39 Cooling control - Extended settings

Options:	No
	Yes

This parameter enables additional functions and communication objects, e.g. "Basic stage cooling".

12.1.40 Basic stage cooling



Note

Only available when the "Extended settings" parameter under "Cooling control" is set on "Yes".

12.1.41 Basic stage cooling - Status object cooling

Options:	No
	Yes

This parameter enables the "Status cooling" communication object.

12.1.42 Basic stage cooling - Mode of the control value

Options:	Normal
	Inverse

The mode of the control value can be used to adapt the control value to de-energised opened (normal) or de-energised closed (inverse) valves.

- *Normal*: Value 0 means "Valve closed".
- *Inverse*: Value 0 means "Valve open".

12.1.43 Basic stage cooling - Hysteresis (x 0.1°C)

Options:	Setting option between 3 - 255
----------	--------------------------------

The hysteresis of the two-point controller specifies the fluctuation range of the controller around the setpoint value. The lower switching point is located at "Setpoint value minus hysteresis" and the upper point is at "Setpoint value plus hysteresis".



Note

This parameter is only available when the "Control value type" parameter is set either on "2-point 1 Bit, Off/On" or "2-point 1 Byte, 0/100%".

Basic stage cooling - Control value difference for sending of cooling control value

Options:	2 %
	5 %
	10 %
	Send cyclic only

The control values of the 0 - 100% PI continuous controller are not transmitted after every calculation. Instead, they are transmitted when the calculation results in a value that is different enough to the previous sent value to make a transmission meaningful. This value difference can be entered here.



Note

This parameter is only available when "Control value type" parameter is set either on "PI continuous, 0 – 100%", "PI PWM, On/Off" or "Fan coil".

12.1.44 Basic stage cooling - Cyclic sending of the control value (min)

Options:	Setting option between 1 - 60 minutes
----------	---------------------------------------

The current control value used by the device can be cyclically transmitted to the bus.



Note

This parameter is only available when the "Control value type" parameter is set either on "2-point 1 Bit, Off/On", "2-point 1 Byte, 0/100%", "PI continuous, 0-100%" or "Fan coil".

12.1.45 Basic stage cooling



Note

Only available when the "Extended settings" parameter under "Cooling control" is set on "Yes".

12.1.46 Basic stage cooling - Maximum control value (0 - 255)

Options:

Setting option between 0 - 255

The maximum control value of the PI controller defines the maximum value outputted by the controller. If a maximum value under 255 is chosen, the value will not be exceeded, even if the controller calculates a higher control value.



Note

This parameter is only available when "Control value type" parameter is set either on "PI continuous, 0 – 100%", "PI PWM, On/Off" or "Fan coil".

12.1.47 Basic stage cooling - Minimum control value for basic load (0 to 255)

Options:

Setting option between 0 - 255

The minimum control value of the PI controller defines the minimum value output by the controller. If a minimum value greater than zero is chosen, the controller will not output a lower value, even if it calculates a value that is lower. This parameter can be used to set a basic load, e.g. for operating surface cooling. Even if the controller calculates the control value zero, a cooling medium will flow through the cooling area to prevent the floor from heating up. Under "Settings of basic load", it is also possible to define whether this basic load will be permanently active or whether it will be switched by the "Basic load" object.



Note

This parameter is only available when "Control value type" parameter is set either on "PI continuous, 0 – 100%", "PI PWM, On/Off" or "Fan coil".

12.1.48 Control of additional cooling stage



Note

Only available when the "Device function" parameter is set on either "Single device" or "Master device" and the control function parameter is set on either "Cooling with additional stage" or "Heating and cooling with additional stages".

Options:	2-point 1 bit, Off/On
	2-point 1 byte, (0/100%)
	PI continuous, 0-100%
	PI PWM, On/Off
	Fan coil

The actuation of the control valve is determined by the selection of the controller type.

- *2-Point 1 Bit, Off/On*: The 2-point control is the simplest type of control. The controller switches on when the room temperature drops below a certain level (setpoint temperature value minus hysteresis) and switches off when a particular value (setpoint temperature value plus hysteresis) is exceeded. The switch-on and switch-off commands are transmitted as 1-bit commands.
- *2-Point 1 Byte, 0/100%*: This is another two-point control as described above. In this case, however, the switch-on and switch-off commands are transmitted as 1-byte values (0% / 100%).
- *PI continuous, 0-100%*: The PI controller adjusts its output value between 0% and 100% to match the difference between the actual value and the setpoint value and enables a precise regulation of the room temperature to the setpoint value. It sends the control value to the bus as a 1-byte value (0% - 100%). To reduce the bus load, the control value is only transmitted if it has changed by a predefined percentage in relation to the previous sent value. The control value can also be transmitted cyclically.
- *PI PWM, On/Off*: This also is a PI controller. Here, the output is a 1-bit command. For this to occur, the calculated control value is converted into a pulse-interval signal.
- *Fan coil*: The fan coil controller operates like the PI continuous controller. In addition, it allows the separate activation of the fan in the fan coil unit (e.g. fan speed levels 1 - 3).

12.1.49 Control of additional cooling stage - Cooling type

Options:	PI continuous, 0 – 100% and PI PWM, On/Off: <ul style="list-style-type: none">▪ Area (e.g. cooling ceiling) 5°C 240 min▪ Free configuration
	Fan coil: <ul style="list-style-type: none">▪ Fan coil 4°C 90 min▪ Free configuration

Two cooling types (area or fan coil) with preset parameters are available to the user.

If the required cooling type is not available, individual parameters can be specified in free configuration.



Note

This parameter is only available when "Control value type" parameter is set either on "PI continuous, 0 – 100%", "PI PWM, On/Off" or "Fan coil".

12.1.50 Control of additional cooling stage - P-component (x 0.1°C)

Options:	Setting option between 10 - 100
----------	---------------------------------

The P-component refers to the proportional band of a control. It fluctuates around the setpoint value and can be used to influence control speed with a PI controller. The smaller the setpoint, the faster it reacts to the control. However, to avoid the risk of an overshoot, this value should not be set too low. A P-component from 0.1 to 25.5 K can be set.



Note

This parameter is only available when "Control value type" parameter is set either on "PI continuous, 0 – 100%", "PI PWM, On/Off" or "Fan coil". In addition, the "Cooling type" parameter must be set on "Free configuration".

12.1.51 Control of additional cooling stage - P-component (min)

Options:	Setting option between 0 - 255
----------	--------------------------------

The I-component refers to the reset time of a control. The integral component has the effect of moving the room temperature slowly toward, and to ultimately reaching, the setpoint. Depending on the type of system used, the reset time has to have different values. In general, the more inactive the overall system, the greater the reset time.



Note

This parameter is only available when "Control value type" parameter is set either on "PI continuous, 0 – 100%", "PI PWM, On/Off" or "Fan coil". In addition, the "Cooling type" parameter must be set on "Free configuration".

12.1.52 Control of additional cooling stage - Extended settings

Options:	No
	Yes

This parameter enables additional functions and communication objects, e.g. "Additional cooling stage".

12.1.53 Additional cooling stage



Note

Only available when the "Extended settings" parameter under "Control of additional cooling stage" is set on "Yes".

12.1.54 Additional cooling stage - Mode of the control value

Options:	Normal
	Inverse

The mode of the control value can be used to adapt the control value to de-energised opened (normal) or de-energised closed (inverse) valves.

- *Normal*: Value 0 means "Valve closed".
- *Inverse*: Value 0 means "Valve open".

12.1.55 Additional cooling stage - Hysteresis (x 0.1°C)

Options:	Setting option between 3 - 255
----------	--------------------------------

The hysteresis of the two-point controller specifies the fluctuation range of the controller around the setpoint value. The lower switching point is located at "Setpoint value minus hysteresis" and the upper point is at "Setpoint value plus hysteresis".



Note

This parameter is only available when the "Control value type" parameter is set either on "2-point 1 Bit, Off/On" or "2-point 1 Byte, 0/100%".

12.1.56 Additional cooling stage - Control value difference for sending of cooling control value

Options:	2%
	5%
	10%

The control values of the 0 - 100% PI continuous controller are not transmitted after every calculation. Instead, they are transmitted when the calculation results in a value that is different enough to the previous sent value to make a transmission meaningful. This value difference can be entered here.



Note

This parameter is only available when "Control value type" parameter is set either on "PI continuous, 0 – 100%", "PI PWM, On/Off" or "Fan coil".

12.1.57 Additional cooling stage - Cyclic sending of the control value (min)

Options:	Setting option between 1 - 60 minutes
----------	---------------------------------------

The current control value used by the device can be cyclically transmitted to the bus.



Note

This parameter is only available when the "Control value type" parameter is set either on "2-point 1 Bit, Off/On", "2-point 1 Byte, 0/100%", "PI continuous, 0-100%" or "Fan coil".

12.1.58 Additional cooling stage - Maximum control value (0 - 255)

Options:	Setting option between 0 - 255
----------	--------------------------------

The maximum control value of the PI controller defines the maximum value outputted by the controller. If a maximum value under 255 is chosen, the value will not be exceeded, even if the controller calculates a higher control value.



Note

This parameter is only available when "Control value type" parameter is set either on "PI continuous, 0 – 100%", "PI PWM, On/Off" or "Fan coil".

12.1.59 Additional cooling stage - Minimum control value for basic load (0 - 255)

Options: Setting option between 0 - 255

The minimum control value of the PI controller defines the minimum value output by the controller. If a minimum value greater than zero is chosen, the controller will not output a lower value, even if it calculates a value that is lower. This parameter can be used to set a basic load, e.g. for operating surface cooling. Even if the controller calculates the control value zero, a cooling medium will flow through the cooling area to prevent the floor from heating up. Under "Settings of basic load", it is also possible to define whether this basic load will be permanently active or whether it will be switched by the "Basic load" object.



Note

This parameter is only available when "Control value type" parameter is set either on "PI continuous, 0 – 100%", "PI PWM, On/Off" or "Fan coil".

12.1.60 Settings of basic load



Note

Only available when the "Device function" parameter is set on either "Single device" or "Master device" and the control function parameter is set on either "Heating with additional stage", "Cooling with additional stage", "Heating and cooling" or "Heating and cooling with additional stages".

12.1.61 Settings of basic load - Minimum control value for basic load > 0

Options: Always active
Activate via object

The function finds application when in the desired area, e.g. with floor heating, the floor is to have a basic warmth. The size of the minimum control value specifies the volume of heating medium that flows through the controlled area, even when the calculation of the control value of the controller would indicate a lower value.

- *Always active*: Here it is possible to define whether this basic load will be permanently active or whether it will be switched via the "Basic load" object.
- *Activate via object*: When this parameter is selected, the basic load function, which means the minimum control value with a value higher than zero, can be activated (1) or deactivated (2). If it is activated, then the heating medium will always be fed through the system with at least the minimum control value. If it is deactivated, the control value can be reduced to zero with the controller.

12.1.62 Combined heating and cooling modes



Note

Only available when the "Device function" parameter is set on either "Single device" or "Master device" and the control function parameter is set on either "Heating and cooling" or "Heating and cooling with additional stages".

12.1.63 Combined heating and cooling modes - Switchover of heating/cooling

Options:	Automatic
	Only via object
	On-site/via extension unit and via object

This function makes it possible to switch between the heating and cooling mode of the device.

- *Automatic*: E.g. for four-conductor systems which allow the switchover between heating and cooling at all times. The device switches automatically between heating and cooling and to the associated setpoint. "Switchover heating/cooling" is a transmitting object.
- *Only via object*: E.g. for two-conductor systems which are operated in heating mode in the winter and cooling mode in the summer. The switchover between heating and cooling and to the associated setpoint is carried out via the corresponding communication object. This function is used when a central switchover of the single room controllers is required. "Switchover heating/cooling" is a receiving object.
- *Local/ via extension unit and via object*: E.g. for four-conductor systems which allow the switchover between heating and cooling at all times. The switchover between heating and cooling and to the associated setpoint is carried out manually on the device by the user of the room or via the "Switchover heating/cooling" object via the bus. "Switchover heating/cooling" is a transmitting and receiving object.

12.1.64 Combined heating and cooling modes - Operating mode after reset

Options:	Cooling
	Heating

After a bus voltage failure, a system reset, or the attachment of a device to the bus coupler, the device starts in the parameterized "Operating mode after reset". The operating mode can be changed when the system is running using the options set under "Switchover heating/cooling".

12.1.65 Combined heating and cooling modes - Heating/cooling control value output

Options:	Via 1 object
	Via 2 objects

This parameter is used to define whether the control value is transmitted to the climate control actuator using one or two objects. If the climate control actuator has separate control value inputs for heating and cooling, or if separate actuators are used, then the option "Via 2 objects" must be selected. Select the option "Via 1 object" if a single actuator only has one object that receives both the heating and the cooling control values.

12.1.66 Combined heating and cooling modes - Additional heating/cooling stage control value output

Options:	Via 1 object
	Via 2 objects

This parameter is used to define whether the control value is transmitted to the climate control actuator using one or two objects. If the climate control actuator has separate control value inputs for heating and cooling, or if separate actuators are used, then the option "Via 2 objects" must be selected. Select the option "Via 1 object" if a single actuator only has one object that receives both the heating and the cooling control values.



Note

This parameter is only available when the "Control function" parameter is set on "Heating and cooling with additional stages".

12.1.67 Setpoint settings



Note

This parameter is only available if the "Device function" parameter is set on either "Single device" or "Master device".

12.1.68 Setpoint settings - Setpoint for heating comfort = setpoint for cooling comfort

Options:	No
	Yes

This parameter is used to configure the manner in which the setpoint adjustment functions.

- *Yes*: The device has the same setpoint for heating and cooling in the comfort mode. The system switches to heating when the temperature drops below the setpoint minus hysteresis. It switches to cooling when the temperature exceeds the setpoint plus hysteresis. The hysteresis is parameterizable.
- *No*: The function has two separate setpoints for heating and cooling in the comfort mode. The device will display the currently active setpoint value. Switching between heating and cooling occurs via the "Switchover heating/cooling" parameter setting.



Note

This parameter is only available when the "Control function" parameter is set on "Heating and cooling" or "heating and cooling with additional stages".

12.1.69 Setpoint settings - Hysteresis for switchover heating/cooling (x 0.1°C)

Options: Setting option between 5 - 100

This parameter specifies the one-sided hysteresis for switching between heating and cooling when "Setpoint heating comfort = Setpoint cooling comfort" is active. If the room temperature exceeds the setpoint temperature value plus hysteresis, the system switches to cooling. If the room temperature falls below the setpoint temperature value minus hysteresis, the system switches to heating.



Note

This parameter is only available when the "Setpoint heating comfort = Setpoint cooling comfort" parameter is set on "Yes".

12.1.70 Setpoint settings - Setpoint temperature for heating and cooling comfort (°C)

Options: Setting option between 10 - 40

Specifies the comfort temperature for heating and cooling when people are present.



Note

This parameter is only available when the "Control function" parameter is set on "Heating and cooling" or "heating and cooling with additional stages".

12.1.71 Setpoint settings - Setpoint temperature for heating comfort (°C)

Options: Setting option between 10 - 40

Specifies the comfort temperature for heating when people are present.



Note

This parameter is only available when the "Control function" parameter is set on "Heating" or "Heating with additional stage".

12.1.72 Setpoint settings - Reduction for standby heating (°C)

Options: Setting option between 10 - 40

Specifies the temperature in heating mode when nobody is present. On devices with a display, this mode is indicated by the standby icon.



Note

This parameter is only available when the "Control function" parameter is set on "Heating", "Heating with additional stage", "Heating and cooling" or "Heating and cooling with additional stages".

12.1.73 Setpoint settings - Reduction for ECO heating (°C)

Options: Setting option between 0 - 15

Specifies the temperature in heating mode when nobody is present. On devices with a display, this mode is indicated by the eco icon.

12.1.74 Setpoint settings - Set-point temperature for frost protection (°C)

Options: Setting option between 5 - 15

Function for protecting the building against the cold. On devices with a display, this mode is indicated by the frost protection icon. Manual operation is blocked.



Note

This parameter is only available when the "Control function" parameter is set on "Heating", "Heating with additional stage", "Heating and cooling" or "Heating and cooling with additional stages".

12.1.75 Setpoint settings - Setpoint temperature for cooling comfort (°C)

Options: Setting option between 10 - 40

Specifies the comfort temperature for cooling when people are present.



Note

This parameter is only available when the "Control function" parameter is set on "Cooling" or "Cooling with additional stage".

12.1.76 Setpoint settings - Increase for standby cooling (°C)

Options: Setting option between 0 - 15

Specifies the temperature in cooling mode when nobody is present. On devices with a display, this mode is indicated by the standby icon.



Note

This parameter is only available when the "Control function" parameter is set on "Cooling", "Cooling with additional stage", "Heating and cooling" or "Heating and cooling with additional stages".

12.1.77 Setpoint settings - Increase for ECO cooling (°C)

Options:	Setting option between 0 - 15
----------	-------------------------------

Specifies the temperature in cooling mode when nobody is present. On devices with a display, this mode is indicated by the eco icon.



Note

This parameter is only available when the "Control function" parameter is set on "Cooling", "Cooling with additional stage", "Heating and cooling" or "Heating and cooling with additional stages".

12.1.78 Setpoint settings - Set-point temperature for heat protection (°C)

Options:	Setting option between 27 - 45
----------	--------------------------------

Function for protecting the building against heat. On devices with a display, this mode is indicated by the heat protection icon. Manual operation is blocked.



Note

This parameter is only available when the "Control function" parameter is set on "Cooling", "Cooling with additional stage", "Heating and cooling" or "Heating and cooling with additional stages".

12.1.79 Setpoint settings - Display indicates

Options:	Current setpoint
	Relative setpoint

The display can indicate either the absolute or relative setpoint value.

- *Current setpoint*: On devices with a display, the setpoint is shown as an absolute temperature, e.g. 21.0°C.
- *Relative setpoint*: On devices with display, the setpoint is indicated as a relative value, e.g. -5°C .. + 5°C.

12.1.80 Setpoint settings - Display indicates

Options:	Current setpoint
	Relative setpoint

The display can indicate either the absolute or relative setpoint value.

- *Current setpoint*: On devices with a display, the setpoint is shown as an absolute temperature, e.g. 21.0°C.
- *Relative setpoint*: On devices with display, the setpoint is indicated as a relative value, e.g. -5°C .. + 5°C.

12.1.81 Setpoint settings - Send current setpoint

Options:	Cyclic and during change
	Only for change

The current setpoint value can be sent to the bus either cyclically and after a change, or only after a change.

12.1.82 Setpoint settings - Cyclic sending of the current set-point temperature (min)

Options:	Setting option between 5 - 240
----------	--------------------------------

This parameter is used to specify the amount of time that will elapse before the current setpoint value is automatically transmitted.



Note

This parameter is only available when the "Send current setpoint" is set on "Only during change".

12.1.83 Setpoint adjustment



Note

This parameter is only available if the "Device function" parameter is set on either "Single device" or "Master device".

12.1.84 Setpoint adjustment — Maximum manual increase during heating mode (0 - 15°C)

Options:	Setting option between 0 - 15
----------	-------------------------------

This preset can be used to limit the manual increase during heating.



Note

This parameter is only available when the "Control function" parameter is set on "Heating", "Heating with additional stage", "Heating and cooling" or "Heating and cooling with additional stages".

12.1.85 Setpoint adjustment — Maximum manual reduction during heating mode (0 - 15°C)

Options:	Setting option between 0 - 15
----------	-------------------------------

This preset can be used to limit the manual decrease during heating.



Note

This parameter is only available when the "Control function" parameter is set on "Heating", "Heating with additional stage", "Heating and cooling" or "Heating and cooling with additional stages".

12.1.86 Setpoint adjustment — Maximum manual increase during cooling mode (0 - 15°C)

Options:	Setting option between 0 - 15
----------	-------------------------------

This preset can be used to limit the manual increase during cooling.



Note

This parameter is only available when the "Control function" parameter is set on "Cooling", "Cooling with additional stage", "Heating and cooling" or "Heating and cooling with additional stages".

12.1.87 Setpoint adjustment — Maximum manual reduction during cooling mode (0 - 15°C)

Options:	Setting option between 0 - 15
----------	-------------------------------

This preset can be used to limit the manual decrease during cooling.



Note

This parameter is only available when the "Control function" parameter is set on "Cooling", "Cooling with additional stage", "Heating and cooling" or "Heating and cooling with additional stages".

12.1.88 Setpoint adjustment - Resetting of the manual adjustment for receipt of a basic setpoint

Options:	No
	Yes

Activating this parameter will cause the manual adjustment to be deleted and the new setpoint value to be provided when a new value is received via the "Basic setpoint" object.

If the parameter is deactivated, the manual adjustment is added to the new base setpoint value. Example: Previous base setpoint value of 21°C + manual adjustment of 1.5°C = 22.5°C. The object receives a new basic setpoint of 18°C plus the previous manual adjustment of 1.5°C for a total of 19.5°C.

12.1.89 Setpoint adjustment - Resetting the manual adjustment for change of operating mode

Options:	No
	Yes

If the device switches to a new operating mode, the manual adjustment is deleted and the parameterized setpoint temperature for the operating mode plus any change by the base setpoint value object will be applied if this parameter is activated. Example: Comfort temperature of 21°C plus manual adjustment of 1.5°C = 22.5°C. Change to Eco with programmed temperature 17°C. The device regulates the temperature to 17°C, since the manual adjustment is deleted.

If the parameter is deactivated, the manual setpoint adjustment will be added to the temperature in the new operating mode. Example: Comfort temperature of 21°C plus manual adjustment of 1.5°C = 22.5°C. If the system switches to Eco with a parameterized temperature of 17°C, the device regulates the temperature to 18.5°C, since the manual adjustment is added.

12.1.90 Setpoint adjustment - Resetting the manual adjustment via object

Options:	No
	Yes

If this parameter is activated, a separate object can be used to delete the manual adjustment at any time. Example of application: Resetting the manual adjustment on all devices located in a building using a system clock.

12.1.91 Setpoint adjustment - Permanent storage of on-site operation

Options:	No
	Yes

If this parameter is activated, the manual settings for setpoint and, where applicable, fan speed level, as well as the value of the "Basic load" object, will be stored in the device and re-activated after a reset. If the device is re-programmed, the stored setpoint values will also be deleted.

12.1.92 Temperature reading - Inputs of temperature reading

Options:	Internal measurement
	External measurement
	Weighted measurement

The room temperature can be measured at the device or fed to the device by an object via the bus. In addition, weighted measuring is also available, in which the weighted average of up to three temperature values (1 x internal, 2 x external) is calculated and used as an input value for control.

12.1.93 Temperature reading - Inputs of weighted temperature reading

Options:	Internal and external measurement
	2 x external measurement
	Internal and 2x external measurement

Specifies the temperature reading inputs for the weighted measurement, in which the calculated weighted average of the inputs is used as an input value for control



Note

This parameter is only available when the "Inputs of temperature reading" parameter is set on "Weighted measurement".

12.1.94 Temperature reading - Weighting of internal measurement (0 to 100%)

Options:	Setting option between 0 - 15
----------	-------------------------------

Specifies the weighting of the internal measurement at a level between 0% and 100%.



Note

This parameter is only available when the "Inputs of weighted temperature reading" parameter is set on "Internal and external measurement" or "Internal and 2x external measurement".

12.1.95 Temperature reading - Weighting of external measurement (0 to 100%)

Options:	Setting option between 0 - 15
----------	-------------------------------

Specifies the weighting of the external measurement at a level between 0% and 100%.



Note

This parameter is only available when the "Inputs of weighted temperature reading" parameter is set on "Internal and external measurement", "2x external measurement" or "Internal and 2x external measurement".

12.1.96 Temperature reading - Weighting of external measurement 2 (0 to 100%)

Options:	Setting option between 0 - 15
----------	-------------------------------

Specifies the weighting of the external measurement 2 at a level between 0% and 100%. When added together with the (0%...100%) weighting of the external measurement, the result must be 100%.



Note

This parameter is only available when the "Inputs of weighted temperature reading" parameter is set on "2x external measurement" or "Internal and 2x external measurement".

12.1.97 Temperature reading - Cyclic sending of the actual temperature (min)

Options: Setting option between 5 - 240

The current actual temperature used by the device can be cyclically transmitted to the bus.

12.1.98 Temperature reading - Difference of value for sending the actual temperature (x 0.1°C)

Options: Setting option between 1 - 100

If the change in temperature exceeds the parameterized difference between the measured actual temperature and the previous actual temperature that was sent, the changed value will be transmitted.

12.1.99 Temperature reading - Adjustment value for internal temperature measurement (x 0.1°C)

Options: Setting option between 1 - 100

Every installation location has different physical conditions (interior or exterior wall, lightweight or solid wall, etc.). In order to use the actual temperature at the installation location as a measured value for the device, a temperature measurement must be performed by an external equalised and / or calibrated thermometer at the installation location. The difference between the actual temperature displayed on the device and the actual temperature determined by the external measurement device must be entered in the parameter field as an "Adjustment value".



Note

- The calibration measurement should not be carried out immediately after the device has been installed. The device should first adjust to the ambient temperature before calibration is carried out. The calibration measurement should be repeated shortly before or after the room is occupied.
- This parameter is only available when the "Inputs of temperature reading" parameter is set on "Internal measurement" or "Weighted measurement".

12.1.100 Temperature reading - Monitoring time for temperature reading (0 = no monitoring) (min)

Options: Setting option between 0 - 120

If no temperature is read within the parameterized time period, the device switches to error mode. It transmits a telegram to the bus via the "Actual temperature error" object and applies the operating mode and control value for error (0 - 255) settings.

12.1.101 Temperature reading — Operating mode for fault

Options:	Cooling
	Heating

In the event of a failure of the actual temperature measurement, the device will no longer be able to independently specify the heating/cooling operating type. As a result, the operating type best suited to protecting the building will be selected.



Note

This parameter is only available when the "Control function" parameter is set on "Heating and cooling" or "heating and cooling with additional stages".

12.1.102 Temperature reading - Control value for fault (0 - 255)

Options:	Setting option between 0 - 255
----------	--------------------------------

In the event of a failure of the actual temperature measurement, the device will no longer be able to independently determine the control value. Therefore, a control value which is suitable for protecting the building will be selected.

12.1.103 Alarm functions



Note

This parameter is only available if the "Device function" parameter is set on either "Single device" or "Master device".

12.1.104 Alarm functions - Condensate water alarm

Options:	No
	Yes

If a fan coil is used, condensation may form during operation as a result of excessive cooling and/or humidity. The associated condensate is typically collected in a container. To protect the container against overflowing, and thus prevent potential damage to devices and/or the building, the container alerts the "Condensation alarm" object (receiving only) that the maximum fill level has been exceeded. This causes the controller to switch to a protective mode. This status is indicated by the corresponding icon on devices that have a display. Local operation is blocked. Operation is only possible again after the alarm has been deactivated.



Note

This parameter is only available when the "Control function" parameter is set either on "Cooling", "Cooling with additional stage", "Heating and cooling" or "Heating and cooling with additional stages".

12.1.105 Alarm functions — Dew point alarm

Options:	No
	Yes

When refrigerating machines are used, dew may appear on the refrigerant supply lines during operation as a result of excessive cooling and/or humidity. The dew indicator reports the dew formation via the "Dew point alarm" object (receiving only). This causes the controller to switch to a protective mode. This status is indicated by the corresponding icon on devices that have a display. Local operation is blocked. Operation is only possible again after the alarm has been deactivated.



Note

This parameter is only available when the "Control function" parameter is set either on "Cooling", "Cooling with additional stage", "Heating and cooling" or "Heating and cooling with additional stages".

12.1.106 Alarm functions - Frost alarm temperature for HVAC and RHCC status (°C)

Options:	Setting option between 0 - 15
----------	-------------------------------

The RHCC status and HVAC objects have a frost alarm bit. If the input temperature of the controller drops below the temperature set in this parameter, then the frost alarm bit is set in the status objects. It is reset when the temperature is exceeded.

12.1.107 Alarm functions - Heat alarm temperature for RHCC status (°C)

Options:	Setting option between 25 - 70
----------	--------------------------------

The RHCC status object has a heat alarm bit. If the input temperature of the controller exceeds the temperature set in this parameter, then the heat alarm bit is set in the status object. It is reset when the temperature falls below the set temperature.

12.1.108 Fan coil settings - Fan speed levels



Note

This parameter is only available if the "Device function" parameter is set on either "Single device" or "Master device" and the "Control value type" parameter is set on "Fan coil".

12.1.109 Fan coil settings - Fan speed levels Number of fan speed levels

Options:	3 levels
	5 levels

This parameter is used to specify the number of fan speed levels the actuator will use to control the fan of the fan coil.

12.1.110 Fan coil settings - Fan speed levels - Format of the level output

Options:	0..5
	0..255
	1 bit m off n
	1 bit m 1 off n

- *0 to 5*: The level values (0..3 or 0..5) are output in the 1-byte format as the counter values 0..3 or 0..5.
- *0 to 255*: The level values (0..3 or 0..5) are output as percentage values. Example 5-stage fan: The level value 1 is output as 20%, and 5 is output as 100%.
- *1 Bit m from n*: The level values (0..3 or 0..5) are output using 1-bit objects. The number of objects available is the same as the number of fan speed levels. For level 2, for example, the 1-bit fan speed level objects 1 and 2 are output as the value 1, while the other fan speed level objects use the value 0.
- *1 Bit 1 from n*: The level values (0..3 or 0..5) are output using 1-bit objects. The number of objects available is the same as the number of fan speed levels. For the level 2, for example, only the 1-bit fan speed level object 2 is output as the value 1. The other fan speed level objects use the value 0.

12.1.111 Fan coil settings - Fan speed levels - Level output

Options:	For manual operation and automatic
	Only for manual operation

This parameter is used to specify when the output of the fan speed level values will occur: either only when the fan speed levels are manually adjusted or also in automatic mode. This setting depends on the options for the fan coil actuator. If the actuator itself controls the fan speed levels in automatic mode based on a derivative of the control value, then the "Only for manual operation" option must be selected. Otherwise, the other option should be selected.

12.1.112 Fan coil settings - Fan speed levels - Lowest manually adjustable level

Options:	Level 0
	Level 1

This parameter is used to preselect the lowest fan speed level that can be set by an operation performed at the device. When level 0 is selected, the heating/cooling system will not be in operation (fan speed level and valve control 0) as long as the current operating mode and operation type are maintained. To avoid damage to the building, level 0 is deactivated after 18 hours and the device is returned to automatic mode.

12.1.113 Fan coil settings - Fan speed levels - Level status evaluation

Options:	No
	Yes

The controller obtains the current fan speed level for controlling a fan coil actuator either by calculating it from the table of level values under "Fan coil settings for heating" or "Fan coil settings for cooling", or by receiving feedback from the fan coil actuator. If the "Yes" option is selected, the "Fan coil step status" object is activated for receiving the fan speed level from the fan coil actuator.

12.1.114 Fan coil settings heating



Note

This parameter is only available if the "Device function" parameter is set on either "Single device" or "Master device" and the "Control value type" parameter is set on "Fan coil". In addition, the "Control function" parameter must be set on either "Heating", "Heating with additional stage", "Heating and cooling" or "Heating and cooling with additional stages".

12.1.115 Fan coil settings for heating - Speed level 1 to 5 up to control value (0 to 255) heating

Options:	Setting option between 0 - 255
----------	--------------------------------

In this parameter, the control values of the controller are assigned to fan speed levels. This assignment is used if the fan speed levels are transmitted together with the control values.



Note

- These level settings should be adjusted to match the settings in the fan coil actuator.
- Setting the "Control value type" to "Fan coil" in the control parameters is only useful for one of either the basic stage or the additional stage. Setting the basic and additional stage parameters to fan coil is not useful, since the control of only one fan coil actuator each for heating and cooling is supported.
- The "Fan speed level 4 - 5 up to control value (0 - 255) heating" parameters are available only when the "Number of fan speed levels" is set on "5 levels".

12.1.116 Fan coil settings for heating - Fan speed level limit heating for eco mode

Options:	No
	Yes

This parameter limits the fan speed level when the system is switched to eco mode.

12.1.117 Fan coil settings for heating - Maximum speed level heating for eco mode

Options:	Setting option between 0 - 5
----------	------------------------------

Specifies the maximum possible fan speed level when the system is switched to eco mode.

12.1.118 Fan coil settings for cooling



Note

This parameter is only available if the "Device function" parameter is set on either "Single device" or "Master device" and the "Control value type" parameter is set on "Fan coil". In addition, the "Control function" parameter must be set on either "Cooling", "Cooling with additional stage", "Heating and cooling" or "Heating and cooling with additional stages".

12.1.119 Fan coil settings for cooling - Speed level 1 to 5 up to control value (0 to 255) cooling

Options:	Setting option between 0 - 255
----------	--------------------------------

In this parameter, the control values of the controller are assigned to fan speed levels. This assignment is used if the fan speed levels are transmitted together with the control values.



Note

- These level settings should be adjusted to match the settings in the fan coil actuator.
- Setting the "Control value type" to "Fan coil" in the control parameters is only useful for one of either the basic stage or the additional stage. Setting the basic and additional stage parameters to fan coil is not useful, since the control of only one fan coil actuator each for heating and cooling is supported.
- The "Fan speed level 4 - 5 up to control value (0 - 255) cooling" parameters are available only when the "Number of fan speed levels" is set on "5 levels".

12.1.120 Fan coil settings for cooling - Fan speed level limit cooling for eco mode

Options:	No
	Yes

This parameter limits the fan speed level when the system is switched to eco mode.

12.1.121 Fan coil settings for cooling - Maximum fan speed level cooling for eco mode

Options:	Setting option between 0 - 5
----------	------------------------------

Specifies the maximum possible fan speed level when the system is switched to eco mode.

12.1.122 Summer compensation



Note

This parameter is only available if the "Device function" parameter is set on either "Single device" or "Master device".

12.1.123 Summer compensation - Summer compensation

Options:	No
	Yes

In order to save energy, and to ensure that the temperature difference occurring during entry and exit of a climate-controlled building stays within comfortable limits, the excessive reduction of room temperature should be prevented during high temperatures in the summer (Summer compensation according to DIN 1946). The room temperature is increased by adjusting the setpoint temperature for cooling.

Raising the room temperature does not, however, mean that you heat up the room. Rather, the adjustment is intended to allow the room temperature to increase to a certain setpoint without cooling. This, for example, prevents the air-conditioning system from further reducing the room temperature to 24°C with an external temperature of 35°C.

However, activation of the summer compensation requires an outside temperature sensor that transmits its measured value to the bus and can be evaluated by the room temperature controller.

The following parameters are available for summer compensation:

- "Lower outside temperature value for summer compensation",
- "Upper outside temperature value for summer compensation",
- "Lower setpoint offset for summer compensation",
- "Upper setpoint offset for summer compensation"

Above the "Upper outside temperature value", the minimum setpoint temperature for cooling is the outside temperature minus the "Upper setpoint offset". The outside temperature has no effect on the minimum setpoint temperature for cooling below the "Lower outside temperature value". Between the "Lower" and "Upper outside temperature value", the minimum setpoint temperature for cooling undergoes floating adjustment by the parameterized setpoint temperature equal to the outside temperature minus the "Lower offset" to a value equal to the outside temperature minus the "Upper setpoint offset" as a function of the outside temperature.

Typical values for summer compensation are:

- 21°C: Lower outside temperature value
- 32°C: Upper outside temperature value
- 0 K: Lower setpoint offset
- 6 K: Upper setpoint offset

This means that a continuous increase of the minimum setpoint value for cooling occurs to a value equal to the outside temperature minus a setpoint offset of 0 to 6 K if the outside temperature increases to 32°C from 21°C.

For example:

For an increasing outside temperature, the minimum setpoint value for cooling will be increased starting at an outside temperature of 21°C. The minimum setpoint temperature for cooling is 25.1°C at an outside temperature of 30°C; 25.5°C at an outside temperature of 31°C; 26°C at an outside temperature of 32°C; and 27°C at an outside temperature of 33°C.

12.1.124 Summer compensation - (Lower) Starting temperature for summer compensation (°C)

Options:	Setting option between -127 - 127
----------	-----------------------------------

The parameter defines the lower outside temperature value up to which temperature value the setpoint correction (summer compensation) is performed based on too high an outside temperature.



Note

This parameter is only available if the "Summer compensation" parameter is set to "Yes".

12.1.125 Summer compensation - Offset of the set-point temperature for the entry into summer compensation (x 0.1°C)

Options:	Setting option between -127 - 127
----------	-----------------------------------

The parameter is used to define how many degrees Kelvin the setpoint value will be increased by during summer compensation when the lower temperature value is reached.

Typical values for summer compensation are:

- 20°C: Lower outside temperature value
- 32°C: Upper outside temperature value
- 0 K: Lower setpoint offset
- 4 K: Upper setpoint offset

That means that a flowing setpoint increase of 0 to 4 K occurs if the outside temperature increases from 20°C to 32°C.



Note

This parameter is only available if the "Summer compensation" parameter is set to "Yes".

12.1.126 Summer compensation - (Upper) exit temperature for summer compensation (°C)

Options:	Setting option between -127 - 127
----------	-----------------------------------

The parameter defines the upper outside temperature value up to which temperature value the setpoint correction (summer compensation) is performed based on too high an outside temperature.



Note

This parameter is only available if the "Summer compensation" parameter is set to "Yes".

12.1.127 Summer compensation - Offset of the set-point temperature for the exit from summer compensation (x 0.1°C)

Options:

Setting option between -127 - 127

The parameter is used to define how many degrees Kelvin the setpoint value will be increased by during summer compensation when the upper temperature value is reached.

Typical values for summer compensation are:

- 20°C: Lower outside temperature value
- 32°C: Upper outside temperature value
- 0 K: Lower setpoint offset
- 4 K: Upper setpoint offset

That means that a flowing setpoint increase of 0 to 4 K occurs if the outside temperature increases from 20°C to 32°C.



Note

This parameter is only available if the "Summer compensation" parameter is set to "Yes".

12.2 Communication objects - RTC

12.2.1 Heating control value

Number	Name	Object function	Data type
1	Heating control value (control value heating/cooling)	Output	1. Switching 2. Percent (0 to 100%)

Description:

1. This object is used to operate a switching actuating drive, e.g. a thermoelectric positioner, that is controlled by a switching/heating actuator.
2. This object is used to control an actuating drive with a continuous input value (0%..100%), e.g. an electromotive actuating drive.

12.2.2 Additional heating stage

Number	Name	Object function	Data type
2	Additional heating stage (additional heating/cooling stage)	Output	1. Switching 2. Percent (0 to 100%)

Description:

1. This object is used to operate a switching actuating drive, e.g. a thermoelectric positioner, that is controlled by a switching/heating actuator.
2. This object is used to control an actuating drive with a continuous input value (0%..100%), e.g. an electromotive actuating drive.



Note

The additional stage can also be used as a parallel second heating stage. To do this, set the parameter for the temperature difference to the basic stage to 0°C.

12.2.3 Cooling control value

Number	Name	Object function	Data type
3	Cooling control value	Output	1. Switching 2. Percent (0 to 100%)

Description:

1. This object is used to operate a switching actuating drive, e.g. a thermoelectric positioner, that is controlled by a switching/heating actuator.
2. This object is used to control an actuating drive with a continuous input value (0%..100%), e.g. an electromotive actuating drive.

12.2.4 Additional cooling stage

Number	Name	Object function	Data type
4	Additional cooling stage	Output	1. Switching 2. Percent (0 to 100%)

Description:

1. This object is used to operate a switching actuating drive, e.g. a thermoelectric positioner, that is controlled by a switching/heating actuator.
2. This object is used to control an actuating drive with a continuous input value (0%..100%), e.g. an electromotive actuating drive.



Note

The additional stage can also be used as a parallel second cooling stage. To do this, set the parameter for the temperature difference to the basic stage to 0°C.

12.2.5 Control On/Off

Number	Name	Object function	Data type
5	1. Control On/Off	Output	Switching
	2. Control On/Off (master)	Output	Switching
	3. Control On/Off (slave)	Output	Switching

If a 0 telegram is received, the controller switches to OFF mode and regulates the temperature to the setpoint value for frost/heat protection. When the controller is switched on again, the remaining operating mode objects are queried in order to determine the new operating mode.



Note

About item 2:

During active ON/OFF controller function in master/slave mode the ON/OFF (master) control object is to be linked with this object.

About item 3:

During active ON/OFF controller function in master/slave mode the ON/OFF (slave) control object is to be linked with this object.

12.2.6 Actual temperature

Number	Name	Object function	Data type
6	1. Actual temperature	Output	2-byte floating point value
	2. Actual temperature weighted	Output	2-byte floating point value

1. The object outputs the measured (room) temperature, adjusted by the calibration value.
2. The object outputs the temperature value which is calculated from the recording and weighting of internal and up to two external temperatures.



Note

An external temperature measurement for room control may be practical for larger rooms and/or floor heating.

12.2.7 External actual temperature

Number	Name	Object function	Data type
7	External actual temperature	Input	2-byte floating point value

2-byte communication object for reading an external temperature value provided via the KNX bus.

12.2.8 External actual temperature 2

Number	Name	Object function	Data type
8	External actual temperature 2	Input	2-byte floating point value

2-byte communication object for reading an additional external temperature value provided via the KNX bus.

12.2.9 Fault, actual temperature

Number	Name	Object function	Data type
9	1. Fault, actual temperature	Output	Switching
	2. Fault, actual temperature (master)	Output	Switching
	3. Fault, actual temperature (slave)	Output	Switching

If one of the parameterized input temperatures is unavailable to the controller for a period longer than the monitoring time, the controller enters the error mode. The error mode is sent to the bus as the value 1.



Note

About item 2:

This object must be connected to the "Fault, actual temperature (slave)" object in order to indicate the error mode.

About item 3:

This object must be connected to the "Fault, actual temperature (slave)" object in order to indicate the error mode.

12.2.10 Local actual temperature

Number	Name	Object function	Data type
10	Local actual temperature	Output	Switching

Not visible!

12.2.11 Current setpoint

Number	Name	Object function	Data type
11	Current setpoint	Output	2-byte floating point value

The object outputs the current setpoint temperature resulting from the following: the parameterized setpoint temperature of the current operation type and operating mode, the manual setpoint temperature adjustment, a change in the base setpoint temperature via the base setpoint value object. This is purely a transmitting object.

12.2.12 Operating mode

Number	Name	Object function	Data type
12	1. Operating mode	Input / output	HVAC mode
	2. Operating mode (master)	Input / output	HVAC mode
	3. Operating mode (slave)	Input / output	HVAC mode

The "Operating mode" object receives, as a 1-byte value, the operating mode that is to be set. Here value 1 means "Comfort", value 2 "Standby", value 3 "Economy" and value 4 "Frost/heat protection".

In addition to manual setpoint adjustment and the adjustment of the basic setpoint value, the setpoint temperature of the controller can also be defined by objects "Superimposed operating mode", "Condensate ware alarm", "Dew alarm", "Window contact", "Control On/Off", "Presence detector" and "Operating mode (listed in decreasing order of priority)".



Note

Item 2:

If the master/slave mode is the active operating mode, the Operating mode (slave) object must be connected to this object.

Item 3:

If the master/slave mode is the active operating mode, the operating mode (master) object must be connected to this object.

12.2.13 Superimposed operating mode

Number	Name	Object function	Data type
13	1. Superimposed operating mode	Input	HVAC mode
	2. Superimposed operating mode (master/slave)	Input	HVAC mode

The "Superimposed operating mode" object receives the operating mode that is to be set as 1-byte value. Here value 0 means "Superimposition inactive", value 1 "Comfort", value 2 "Standby", value 3 "Economy" and value 4 "Frost/heat protection".

In addition to manual setpoint adjustment and the adjustment of the basic setpoint value, the setpoint temperature of the controller can also be defined by objects "Superimposed operating mode", "Condensate ware alarm", "Dew alarm", "Window contact", "Control On/Off", "Presence detector" and "Operating mode (listed in decreasing order of priority).



Note

Item 2:

If the master/slave mode is active, the "Superimposed operating mode" object of the master and the slave must be connected to the group address of the transmitter.

12.2.14 Window contact

Number	Name	Object function	Data type
14	1. Window contact	Input	Switching
	2. Window contact (master/slave)	Input	Switching

The object uses the value 1 to signal an open window to the controller. If no other object with a higher priority is present, then the "Window contact" message causes the controller to be set to the setpoint value for frost/heat protection. In addition to manual setpoint adjustment and the adjustment of the basic setpoint value, the setpoint temperature of the controller can also be defined by objects "Superimposed operating mode", "Condensate water alarm", "Dew alarm", "Window contact", "Control On/Off", "Presence detector" and "Operating mode (listed in decreasing order of priority).



Note

Item 2:

If the master/slave mode is active, the "Window contact (master/slave)" object of the master and the slave must be connected to the group address of the transmitter.

12.2.15 Presence detector

Number	Name	Object function	Data type
15	1. Presence detector	Input	Switching
	2. Presence detector (master/slave)	Input	Switching

This object transmits the value 1 to the controller to signal that there are people in the room. If not other object with a higher priority is present, then the "Presence detector" causes the controller to be set to the comfort setpoint value. In addition to manual setpoint adjustment and the adjustment of the basic setpoint value, the setpoint temperature of the controller can also be defined by objects "Superimposed operating mode", "Condensate water alarm", "Dew alarm", "Window contact", "Control On/Off", "Presence detector" and "Operating mode (listed in decreasing order of priority).



Note

Item 2:

If the master/slave mode is active, the "Presence detector (master/slave)" object of the master and the slave must be connected to the group address of the transmitter.

12.2.16 Heating status

Number	Name	Object function	Data type
16	Heating status	Output	Switching

The room temperature controller sends an ON telegram via the "Heating status" object as soon as it is active in the heating mode. If the controller is in the inactive zone between heating and cooling or is in cooling mode, the room temperature controller transmits an OFF telegram on the "Heating status" object.

12.2.17 Cooling status

Number	Name	Object function	Data type
17	Cooling status	Output	Switching

The room temperature controller sends an ON telegram via the "Cooling status" object as soon as it is active in the cooling mode. If the controller is in the inactive zone between heating and cooling or is in heating mode, the room temperature controller transmits an OFF telegram on the "Cooling status" object.

12.2.18 Basic load

Number	Name	Object function	Data type
16	Basic load	Input / output	Switching

This object uses the value 1 to activate a parameterized base load, i.e. a minimum control value greater than zero. The value 0 deactivates the base load. When the base load is deactivated, the control value can be lowered all the way to zero if necessary when the setpoint temperature is reached, despite the minimum value set in the parameter.



Note

Deactivating the basic load for a floor heating system is always useful in the summer, since it saves heating energy.

12.2.19 Switchover heating/cooling

Number	Name	Object function	Data type
17	Switchover heating/cooling	Input / output	Switching

1. **Automatic:** If the switchover between heating and cooling is performed automatically by the room temperature controller, then this object is used to provide information on the current heating (0) or cooling (1) status to the KNX bus. It is a transmitting object.
2. **Only via object:** The switchover between heating and cooling on the room temperature controller occurs solely via this 1-bit communication object. The value (0) activates the heating mode, and the value (1) activates the cooling mode. This is a receiving object.
3. **Manual or via object:** The switchover between heating and cooling on the room temperature controller occurs by user interaction or via the 1-bit communication object. The information on the respective heating (0) or cooling (1) status is available to the KNX bus. This is a receiving and sending object.

12.2.20 Fan coil manual

Number	Name	Object function	Data type
18	1. Fan coil manual	Output	Switching
	2. Fan coil manual (master)	Output	Switching
	3. Fan coil manual (slave)	Output	Switching

Using this 1-bit communication object, a fan coil actuator can be placed in manual fan mode or returned to automatic fan mode. In the automatic fan mode of the fan coil actuator, the fan's rotational speed is defined in the fan coil actuator using the control value. In manual fan operation, the user of the room temperature controller can set the fan's rotational speed as needed. This setting will remain active until it is reset. The fan speed level 0 is an exception: to avoid damage to the building, automatic mode is activated again 18 hours after fan speed level 0 is selected.



Note

Item 2:

If fan coil manual is active in the master/slave mode, the fan coil manual (slave) object must be connected to this object.

Item 3:

If fan coil manual is active in the master/slave mode, the fan coil manual (master) object must be connected to this object.

12.2.21 Fan coil step

Number	Name	Object function	Data type
19	1. Fan coil step	Output	2-byte floating point value
	2. Fan coil step (master)	Output	2-byte floating point value
	3. Fan coil step (slave)	Output	2-byte floating point value

The fan speed level in the fan coil actuator is selected via the 1-byte communication object. Whether the fan speed level information is transmitted in manual or also in automatic fan speed level mode can be set. The formats that can be selected for the 1-byte communication object are the fan speed level (0..5) or a percentage value (0..100%) which is calculated back to a fan speed level in the fan coil actuator.



Note

Item 2:

If fan coil step is active in the master/slave mode, the fan coil step (slave) object must be connected to this object.

Item 3:

If fan coil step is active in the master/slave mode, the fan coil step (slave) object must be connected to this object.

12.2.22 Fan coil step status

Number	Name	Object function	Data type
20	Fan coil step status	Input / output	2-byte floating point value

Using the "Fan coil step status" object, the room temperature controller receives the current fan speed level of the fan coil actuator.

12.2.23 Fan speed level 1

Number	Name	Object function	Data type
21	Fan speed level 1	Output	Switching

This 1-bit communication object is used to output the active status (1) of the fan speed level, while the other fan speed levels are deactivated (0), depending on the parameter setting. If the fan speed level is inactive, the object has a value of (0).

12.2.24 Fan speed level 2

Number	Name	Object function	Data type
22	Fan speed level 2	Output	Switching

This 1-bit communication object is used to output the active status (1) of the fan speed level, while the other fan speed levels are deactivated (0), depending on the parameter setting. If the fan speed level is inactive, the object has a value of (0).

12.2.25 Fan speed level 3

Number	Name	Object function	Data type
23	Fan speed level 3	Output	Switching

This 1-bit communication object is used to output the active status (1) of the fan speed level, while the other fan speed levels are deactivated (0), depending on the parameter setting. If the fan speed level is inactive, the object has a value of (0).

12.2.26 Fan speed level 4

Number	Name	Object function	Data type
24	Fan speed level 4	Output	Switching

This 1-bit communication object is used to output the active status (1) of the fan speed level, while the other fan speed levels are deactivated (0), depending on the parameter setting. If the fan speed level is inactive, the object has a value of (0).

12.2.27 Fan speed level 5

Number	Name	Object function	Data type
25	Fan speed level 5	Output	Switching

This 1-bit communication object is used to output the active status (1) of the fan speed level, while the other fan speed levels are deactivated (0), depending on the parameter setting. If the fan speed level is inactive, the object has a value of (0).

12.2.28 Basic setpoint

Number	Name	Object function	Data type
26	Basic setpoint	Input	2-byte floating point value

This 2-byte communication object can be used to change/adjust the parameterized basic setpoint value via the KNX bus. Parameters can be used to define whether the value received by this object is interpreted as "Setpoint heating comfort", "Setpoint cooling comfort" or an average between heating and cooling comfort.

12.2.29 Resetting manual setpoints

Number	Name	Object function	Data type
27	Resetting manual setpoints	Input	Switching

This 1-bit communication object is used to reset the manual setpoint adjustment that was set on the device.

12.2.30 Dew point alarm

Number	Name	Object function	Data type
28	Dew point alarm	Input	Switching

This 1-bit communication object is used to place the controller in the dew point alarm mode. This causes the current setpoint value to be set to the heat protection setpoint value in order to keep the structure from being damaged by dew.



Note

This protective mechanism is only active in the cooling mode. It remains in place until it is cancelled by the value (0). When an alarm is active, manual operation of the controller is blocked. This information is indicated by a corresponding icon on the control unit.

12.2.31 Condensate water alarm

Number	Name	Object function	Data type
29	1. Condensate water alarm	Input	Switching
	2. Condensate water alarm (master/slave)	Input	Switching

This 1-bit communication object is used to place the controller in the condensation alarm mode. This causes the current setpoint value to be set to the heat protection setpoint value in order to keep the structure from being damaged by an overflowing condensation container.



Note

Item 1:

This protective mechanism is only active in the cooling mode. It remains in place until it is cancelled by the value (0). When an alarm is active, manual operation of the controller is blocked. This information is indicated by a corresponding icon on the device.

Item 2:

- This protective mechanism is only active in the cooling mode. It remains in place until it is cancelled by the value (0). When an alarm is active, manual operation of the controller is blocked. This information is indicated by a corresponding icon on the device.
- When the master/slave mode is active, the condensate water alarm (master/slave) objects must be connected to the alarm transmitter.

12.2.32 Outside temperature for summer compensation

Number	Name	Object function	Data type
30	Outside temperature for summer compensation	Input	2-byte floating point value

In order to save energy, and to ensure that the temperature difference occurring during entry and exit of a climate-controlled building stays within comfortable limits, the reduction of room temperature by cooling devices should be limited as a function of the outside temperature (summer compensation). This, for example, prevents the air-conditioning system from further reducing the room temperature to 24°C with an outside temperature of 35°C.

This function can only be used with an outside temperature sensor. This 2-byte communication object must then be used to provide the controller with the current outside temperature.

12.2.33 Summer compensation active

Number	Name	Object function	Data type
31	Summer compensation active	Output	Switching

This 1-bit communication object is used to indicate via the bus whether the summer compensation is active (1) or inactive (0). If it is active, the setpoint value configured for the cooling mode is increased by the summer compensation function. A decrease of the cooling mode setpoint temperature below the value calculated by the parameterized summer compensation function is not possible. An increase of the setpoint temperature for the cooling mode is always possible.

12.2.34 Setpoint reached

Number	Name	Object function	Data type
32	Setpoint reached	Output	Switching

When the setpoint set on the device in comfort mode has been reached it is sent by means of value (1) as information to the KNX bus via the 1-bit communication object. The function is started by activating the comfort or presence mode. If the reaching of the setpoint temperature is interfered with by the preselection of a different operating mode or by adjustment to a new setpoint, value (0) is sent.

12.2.35 Fahrenheit

Number	Name	Object function	Data type
33	1. Fahrenheit	Input / output	Switching
	2. Fahrenheit (master)	Input / output	Switching
	3. Fahrenheit (slave)	Input / output	Switching

The temperature indication on the display can be changed from Celsius (°C) to Fahrenheit (°F). The conversion from Celsius to Fahrenheit always takes place in the display unit, since only Celsius values are sent over the KNX bus. The value (0) results in a temperature indication in Celsius, while the value (1) results in Fahrenheit.



Note

Item 2:

If the Fahrenheit object is active in the master/slave mode, the Fahrenheit (slave) object must be connected to this object.

Item 3:

If the Fahrenheit object is active in the master/slave mode, the Fahrenheit (master) object must be connected to this object.

12.2.36 Display backlighting

Number	Name	Object function	Data type
34	Display backlighting	Input / output	Switching

The display backlighting is activated with value (1) and deactivated with value (0) via the 1-bit communication object.



Note

This function is mainly used in rooms where backlighting during the night is considered to be a disturbing factor, such as in hotel rooms and bedrooms.

12.2.37 On/Off request

Number	Name	Object function	Data type
35	1. On/off request (master)	Input	Switching
	2. On/off request (slave)	Input	Switching

This 1-bit communication object must be connected to the respective slave communication object in order to synchronise the devices in the master/slave configuration.

12.2.38 Setpoint display

Number	Name	Object function	Data type
36	1. Setpoint display (master)	Input / output	2-byte floating point value
	2. Setpoint display (slave)	Input / output	2-byte floating point value

This 2-byte communication object must be connected to the respective slave communication object in order to synchronise the devices in the master/slave configuration.

12.2.39 Request setpoint

Number	Name	Object function	Data type
37	1. Request setpoint (master)	Input	Percent (0..100%)
	2. Request setpoint (slave)	Input	Percent (0..100%)

This 1-byte communication object must be connected to the respective slave communication object in order to synchronise the devices in the master/slave configuration.

12.2.40 Confirm setpoint

Number	Name	Object function	Data type
38	1. Confirm setpoint (master)	Input / output	Percent (0..100%)
	2. Confirm setpoint (slave)	Input / output	Percent (0..100%)

This 1-byte communication object must be connected to the respective slave communication object in order to synchronise the devices in the master/slave configuration.

12.2.41 Heating/cooling request

Number	Name	Object function	Data type
39	1. Heating/cooling request (master)	Input	Switching
	2. Heating/cooling request (slave)	Input	Switching

This 1-bit communication object must be connected to the respective slave communication object in order to synchronise the devices in the master/slave configuration.

12.2.42 Request fan speed level manual

Number	Name	Object function	Data type
40	1. Request fan speed level manual (master)	Input	Switching
	2. Request fan speed level manual (slave)	Input	Switching

This 1-bit communication object must be connected to the respective slave communication object in order to synchronise the devices in the master/slave configuration.

12.2.43 Request fan speed level

Number	Name	Object function	Data type
41	1. Request fan speed level (master)	Input	Percent (0..100%)
	2. Request fan speed level (slave)	Input	Percent (0..100%)

This 1-byte communication object must be connected to the respective slave communication object in order to synchronise the devices in the master/slave configuration.

12.2.44 Confirm fan speed level

Number	Name	Object function	Data type
42	1. Confirm fan speed level (master)	Input / output	Percent (0..100%)
	2. Confirm fan speed level (slave)	Input / output	Percent (0..100%)

This 1-byte communication object must be connected to the respective slave communication object in order to synchronise the devices in the master/slave configuration.

12.2.45 Controller status RHCC

Number	Name	Object function	Data type
43	Controller status RHCC	Output	2-byte floating point value

This communication object outputs the heating/cooling operation type, active/inactive operation, the frost and heat alarm, and the error (actual temperature reading failure) in accordance with the specification for the RHCC (Room Heating Cooling Controller) status.

12.2.46 Controller status HVAC

Number	Name	Object function	Data type
44	1. Controller status HVAC	Output	Percent (0..100%)
	2. Controller status HVAC (master)	Output	Percent (0..100%)
	3. Controller status HVAC (slave)	Output	Percent (0..100%)

This communication object outputs the current operating mode, the heating/cooling mode, active/inactive mode, the frost alarm and the dew point alarm in accordance with the specification for the HVAC (Heating Ventilation Air Conditioning) status.



Note

Item 2:

If the master/slave mode is active, the HVAC status (slave) object must be connected to this object.

Item 3:

If the master/slave mode is active, the HVAC status (master) object must be connected to this object.

12.2.47 Commissioned

Number	Name	Object function	Data type
45	Commissioned	Output	Switching

The controller uses this 1-bit communication object to send a cyclical "sign of life". This signal can be used to monitor the device, e.g. by means of a visualisation.

Contact us

A member of the ABB Group

Busch-Jaeger Elektro GmbH

PO box

58505 Lüdenscheid

Freisenbergstraße 2

58513 Lüdenscheid

Germany

www.BUSCH-JAEGER.de

info.bje@de.abb.com

Central sales service:

Phone: +49 (0) 2351 956-1600

Fax: +49 (0) 2351 956-1700

Notice

We reserve the right to at all times make technical changes as well as changes to the contents of this document without prior notice.

The detailed specifications agreed to at the time of ordering apply to all orders. ABB accepts no responsibility for possible errors or incompleteness in this document.

We reserve all rights to this document and the topics and illustrations contained therein. The document and its contents, or extracts thereof, must not be reproduced, transmitted or reused by third parties without prior written consent by ABB.

Copyright© 2015 Busch-Jaeger Elektro GmbH
All rights reserved