

Wind sensor with 0-10 V interface



Colour **Article no.**
 polar white 663591

Table of Contents

1.	Function	1
2.	Installation	1
3.	Technical Data	2

1. Function

The wind sensor evaluates the wind speed and converts it into an analogue 0 to 10 V output voltage. The wind sensor can be connected to the weather station REG-K/4-gang or the analogue input REG-K/4-gang. The power supply required to operate the wind sensor is made available by these devices.

2. Installation

The wind sensor is screwed onto e.g. a cross member or a mast with a mounting bracket (optional). A horizontal adjustment is required.

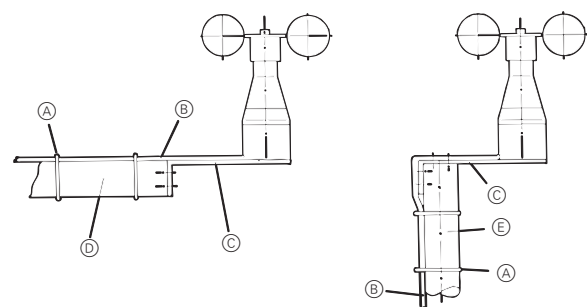

- (A) Cable binder
- (B) Cable
- (C) Mounting bracket
- (D) Cross member
- (E) Mast

The measured-value cable is fitted tightly to e.g. the cross member with clips, cable binders or similar fixing material so that the cable is not damaged at higher wind speeds by flapping and wearing through.

Selection of the installation site

In general, wind measuring devices should record the wind conditions in a broad radius. To obtain comparable values when determining the surface wind, measurements should be taken at a height of 10 metres above even, undisrupted ground. Undisrupted ground means: the distance between the anemometer and the obstacle should be at least ten times the height of the obstacle (see VDI 3786). If this regulation cannot be complied with, the anemometer should be installed at a height so that the measured values are influenced as little as possible by the obstacles (approx. 6 to 10 m above the obstacle).

On flat roofs, the anemometer should be placed in the middle of the roof instead of on the edge so that any preferential directions are avoided.

Maintenance

If the device is installed correctly, it is maintenance-free.

High levels of environmental pollution can block the slit on the wind sensor between the rotating and fixed parts. This slit must always be kept clean.

3. Technical Data

Measuring range: 0.7 - 40 m/s, linear
 Electr.output: 0 - 10 V
 External supply
 Voltage: DC 24 V (DC 18 - 32 V)
 Power consumption: approx. 12 mA
 General data
 Load: max. 60 m/s transient
 Ambient temperature: -25 °C to +60 °C
 EC guidelines: corresponds to low voltage guideline 73/23/EEC; corresponds to EMC guideline 89/336/EEC
 Incoming cable: 3 m, LiYY 6x0.25 mm²
 Fixing method: Mounting bracket
 Mounting position: vertical

Connection example:

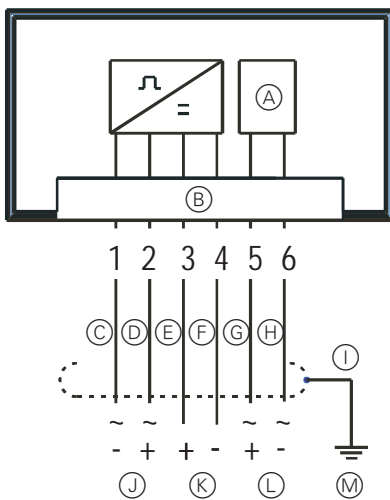

- (A) Heating
- (B) Cable LiYY
- (C) white
- (D) brown
- (E) green
- (F) yellow
- (G) grey
- (H) pink
- (I) Shield
- (J) Supply 18 to 32 V DC
- (K) Output 0 to 10 V = 0.7 to 40 m/s

- (L) Supply for heating 24 V AC/DC
- (M) Earth